

Steering and Suspension Systems

- Steering Systems
 - Skid-Steer
 - Differential drive
 - Trailer steering
 - Ackerman steering
 - Actively controlled steering (Independent / explicit)
 - Holonomic vs. Nonholonomic Systems
- Suspension Systems
 - Rigid Suspension
 - Independent Suspension
 - Articulated / Split-Body Suspension
 - Rocker-Bogie Configurations
 - Segmented-Body Rovers
 - Active Suspension

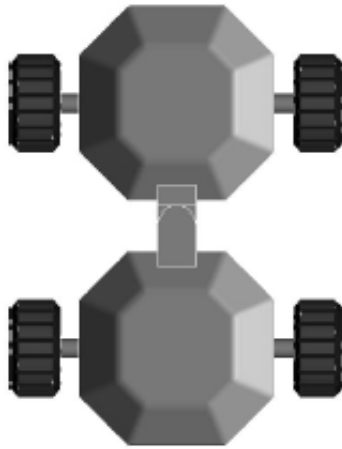

Steering Schemes



ARTICULATED

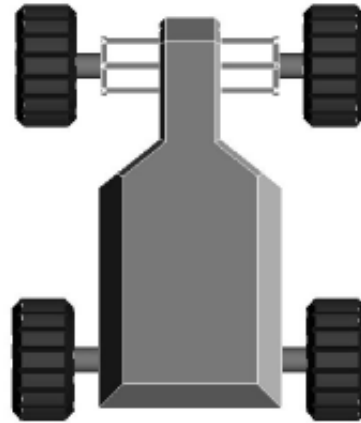

COORDINATED
(Ackermann Type)

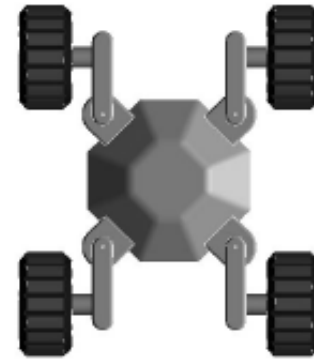

INDEPENDENT
EXPLICIT

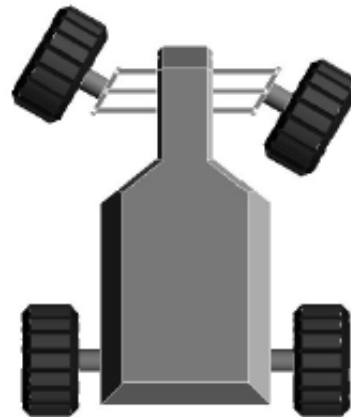
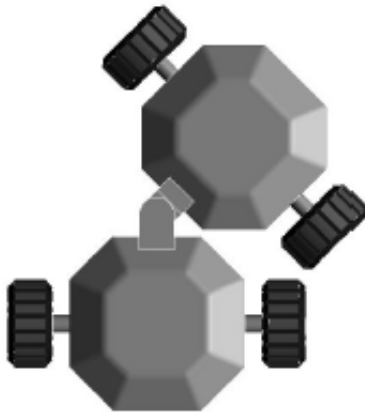

Fixed Suspension - Electric Tractor (JSC)



ET "Suspension"



Fixed Suspension in Hilly Terrain



ATRV Skid-Steer Robots

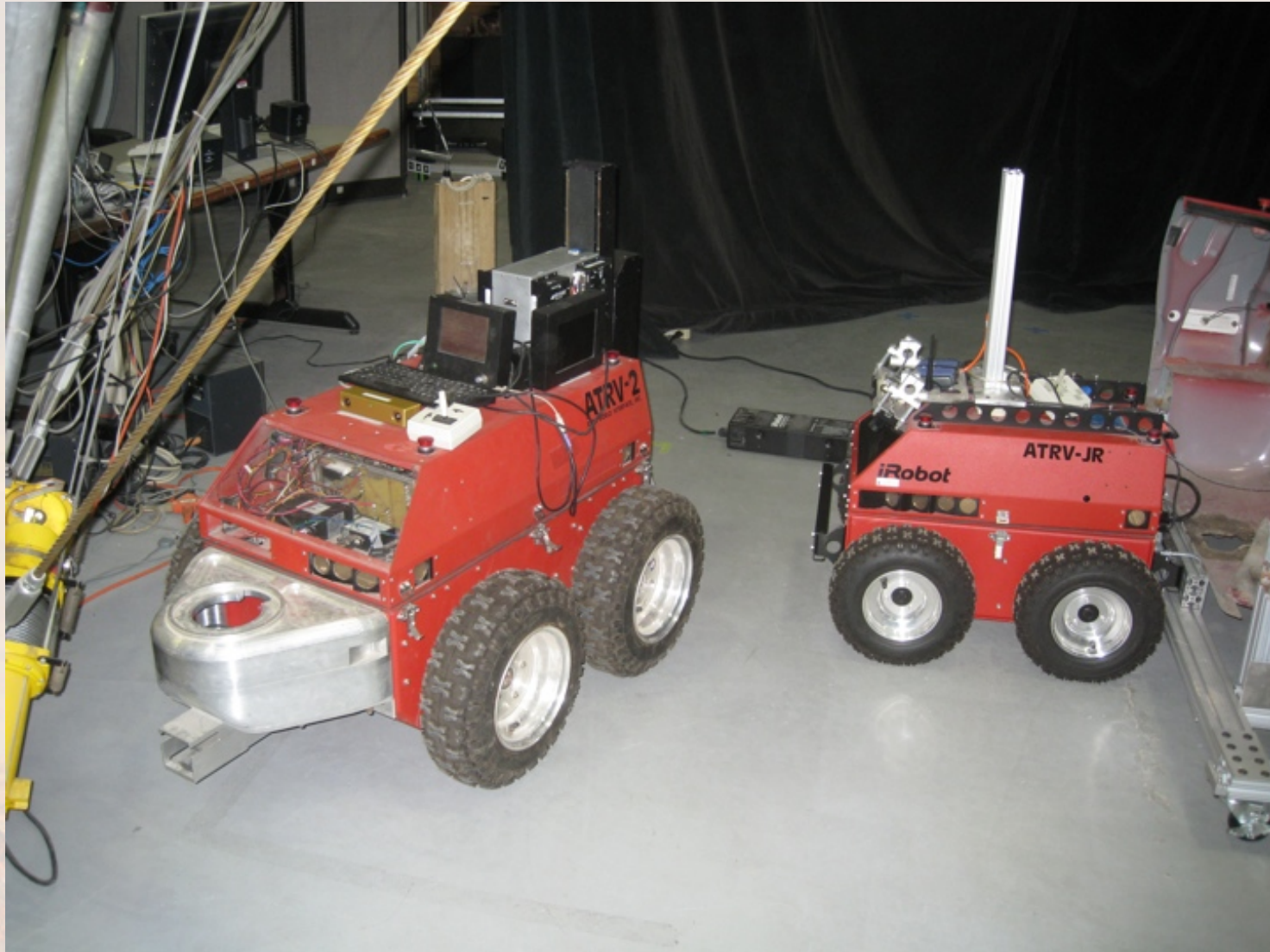

Laboratory Robot (CMU)



Laboratory Robot (CMU)



RAVEN (UMd/ASU)



UNIVERSITY OF
MARYLAND

RAVEN in Mobility Testing



UNIVERSITY OF
MARYLAND

Steering and Suspension Systems
ENAE 788X - Planetary Surface Robotics

Tooth (JPL) - Ackerman Steering



Hyperion (CMU)



UNIVERSITY OF
MARYLAND

Hyperion (CMU) - Trailer Steering



Independent Suspension (Towed Vehicle)

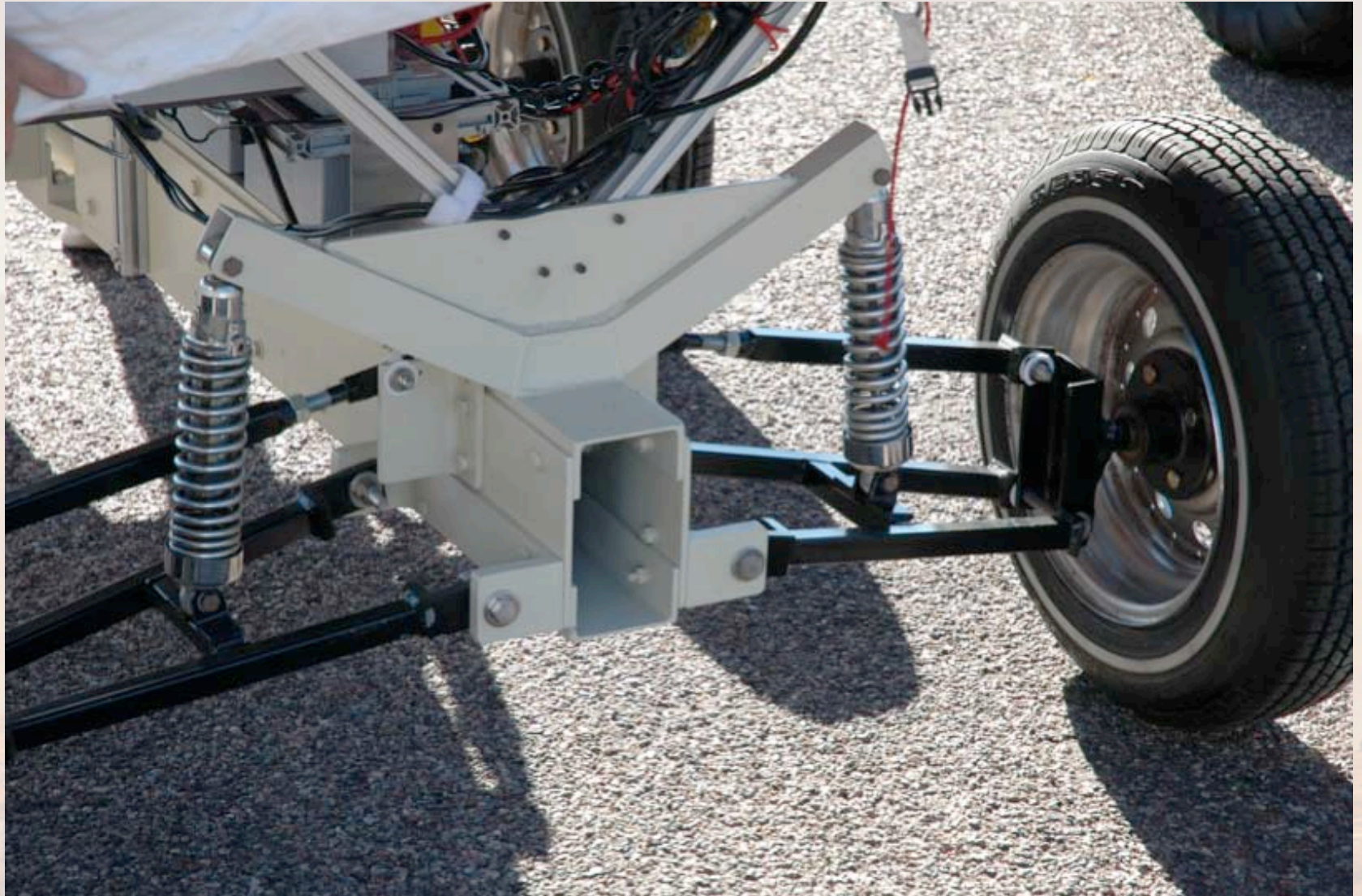

SCOUT Astronaut Support Rover (JSC)



SCOUT Suspension and Steering



Articulating Suspension - Nomad (CMU)



UNIVERSITY OF
MARYLAND

Steering and Suspension Systems
ENAE 788X - Planetary Surface Robotics

Nomad Transforming Chassis

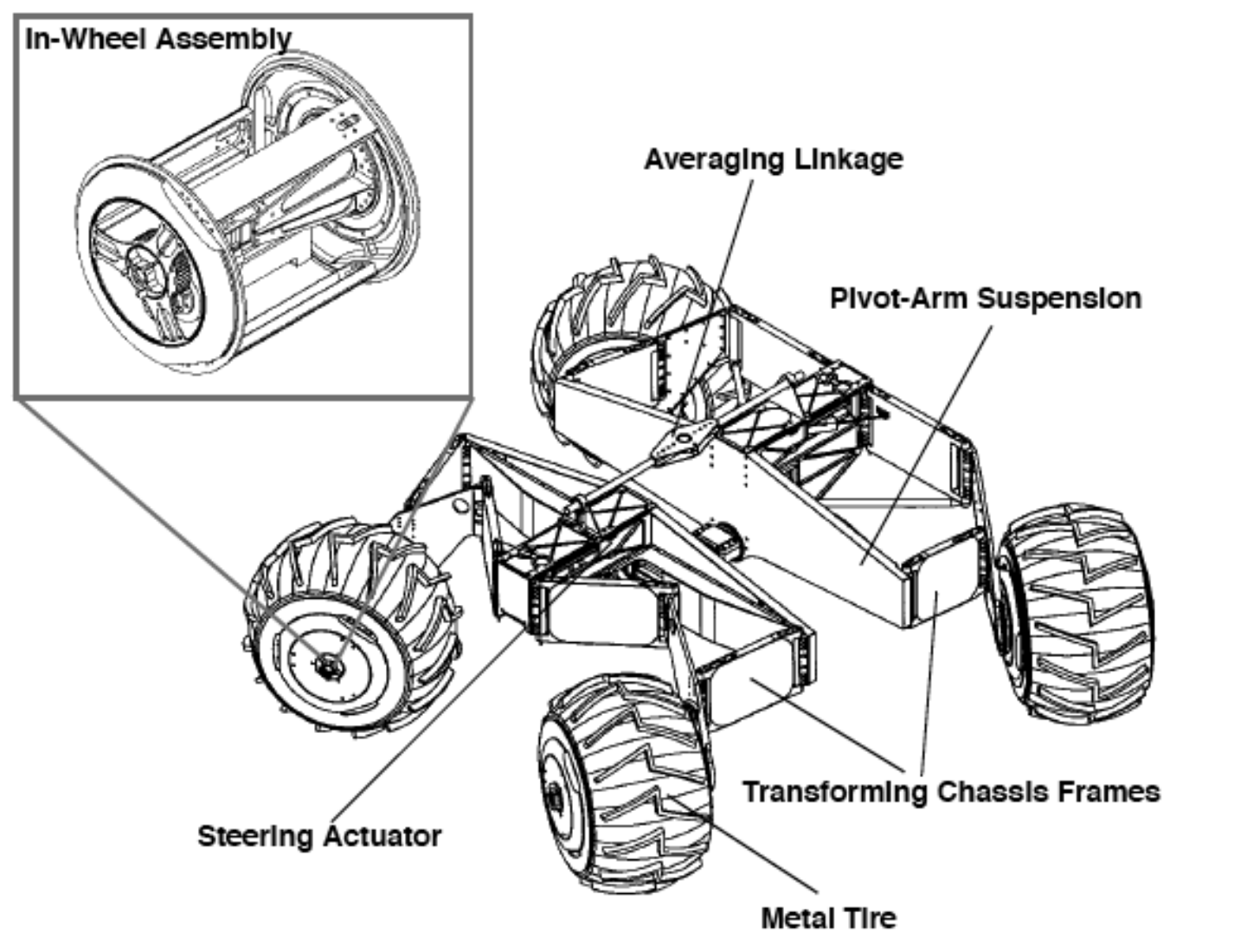

Nomad in Rough Terrain



Nomad Chassis/Steering System

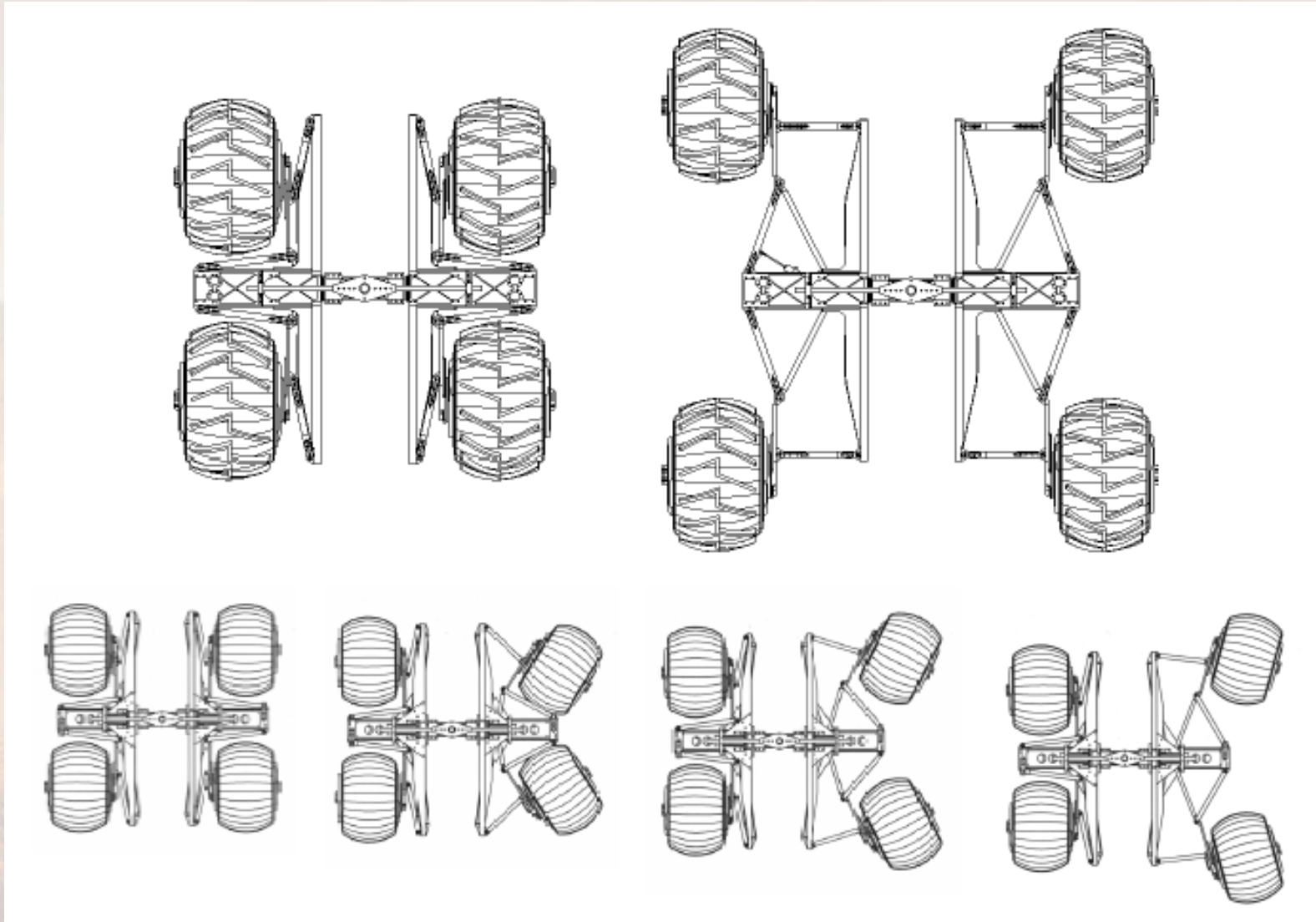

Nomad with Wheels Stowed



Nomad Steering Schemes

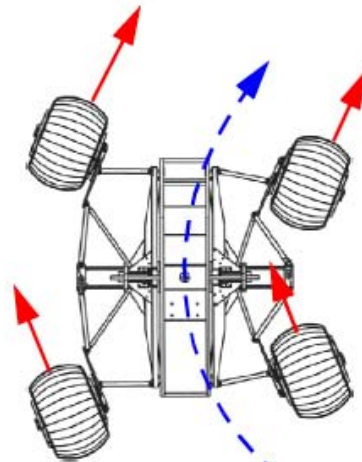

Dual Ackermann

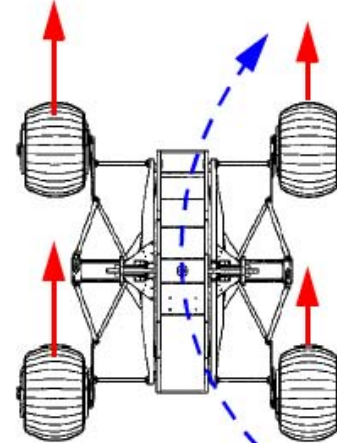

Differential Skid Steering

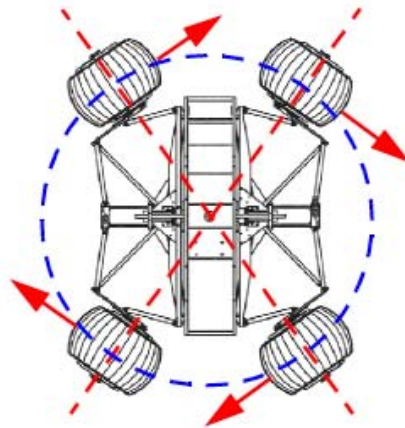

Rolling Point Turn

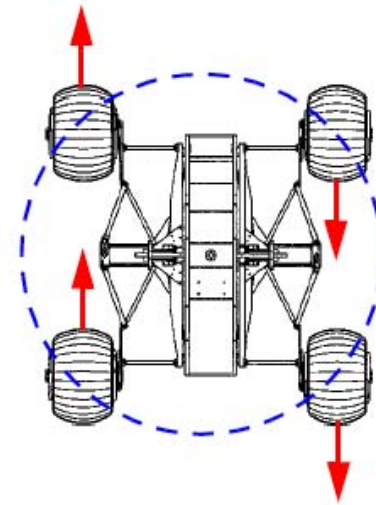

Skid Steering Point Turn



Nomad Power in Skid and Explicit Turns

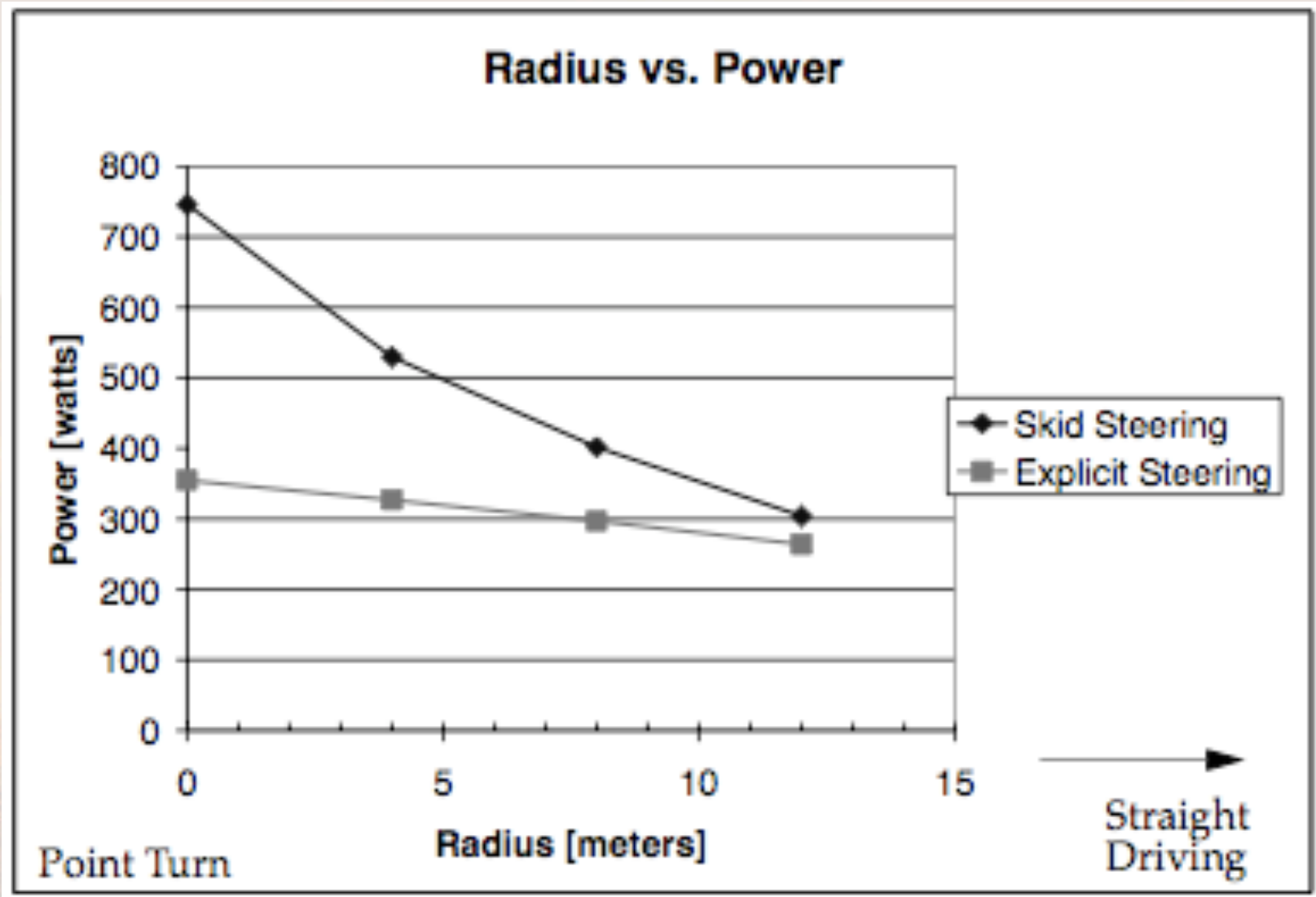

Steering Power Comparison with Fixed Loads

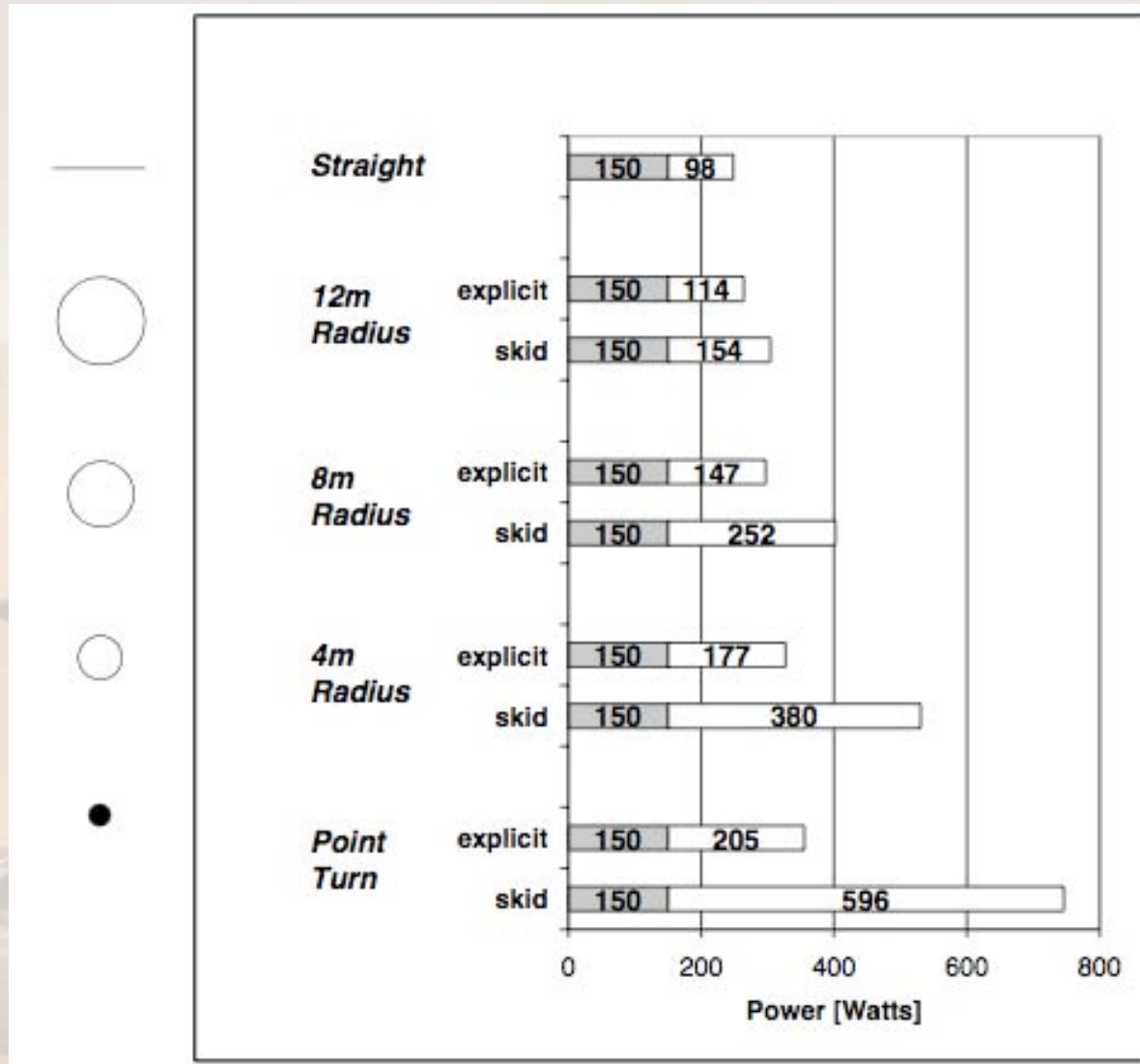

Nomad Wheel Torques in Skid Turn

% of total torque contribution by each wheel for 4m radius skid steering turns

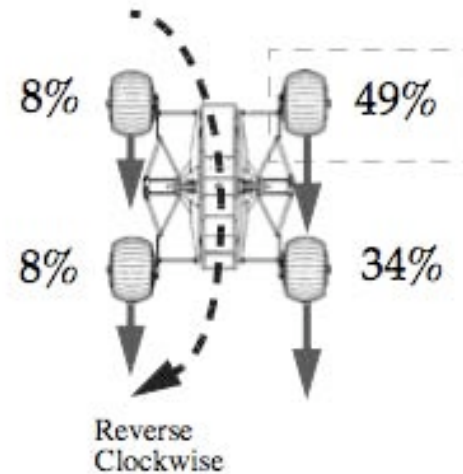
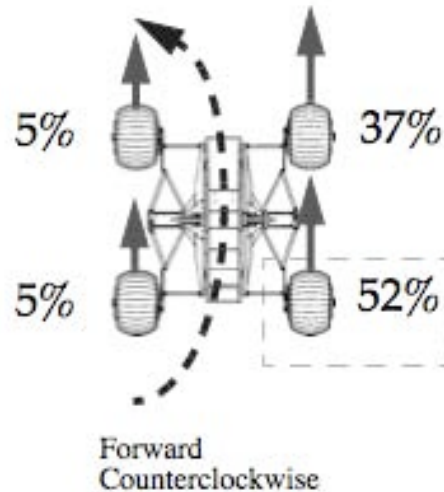
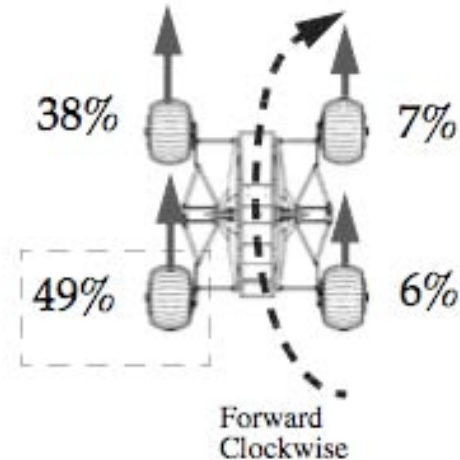

Split-Body Rovers (Sandia Labs)

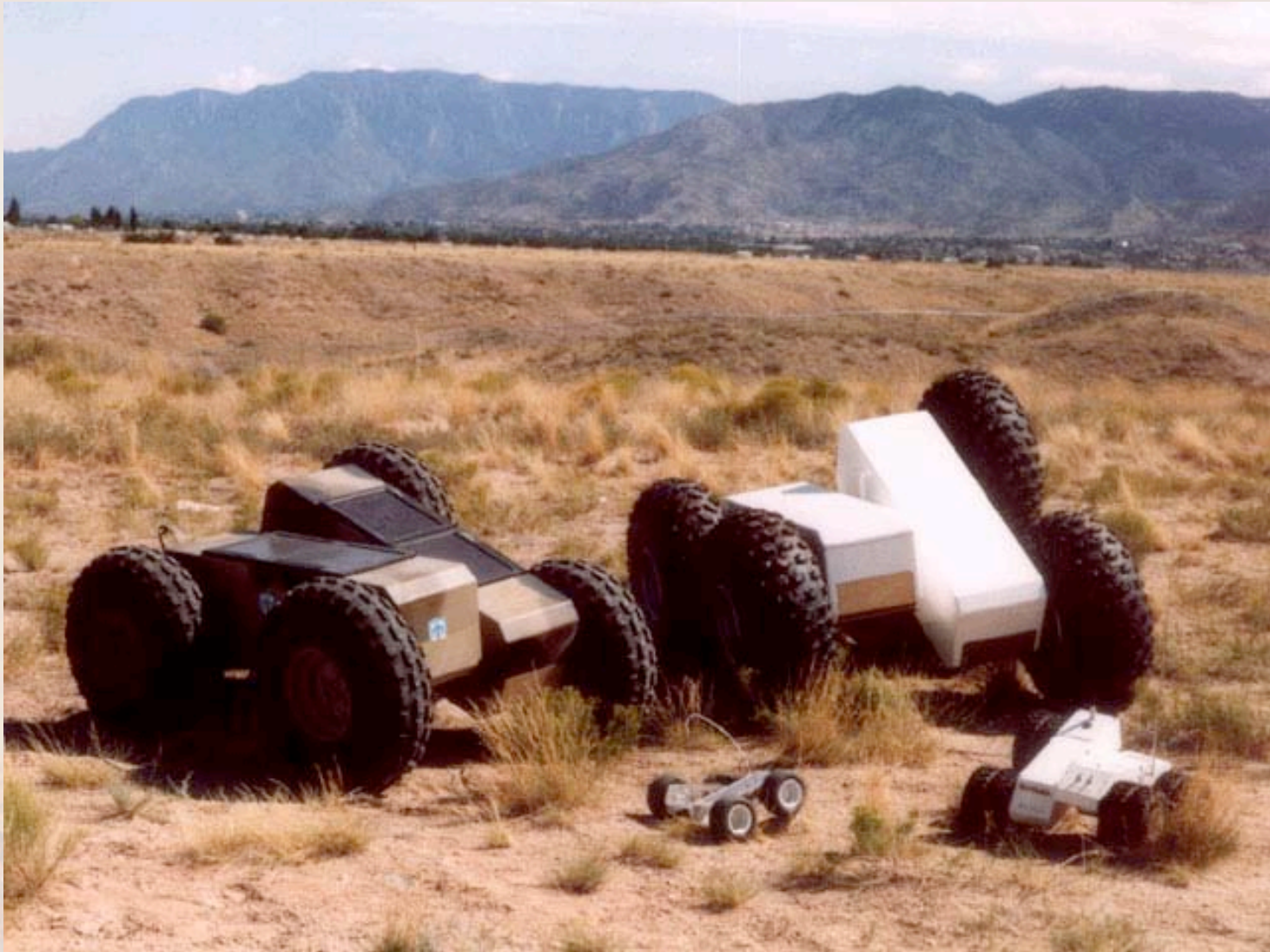

Ratler (Sandia Labs)

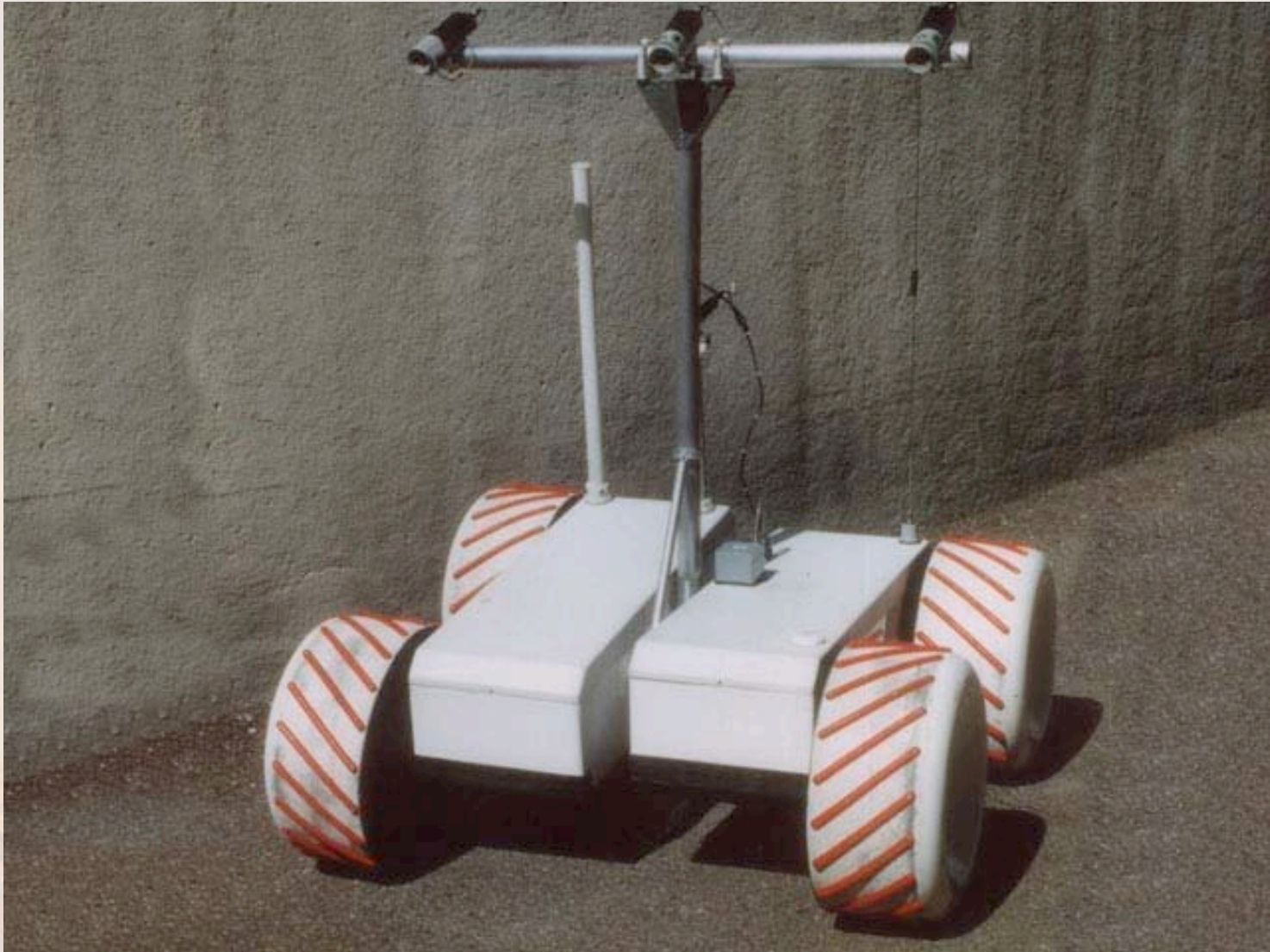

Rocker-Bogie - Rocky 4

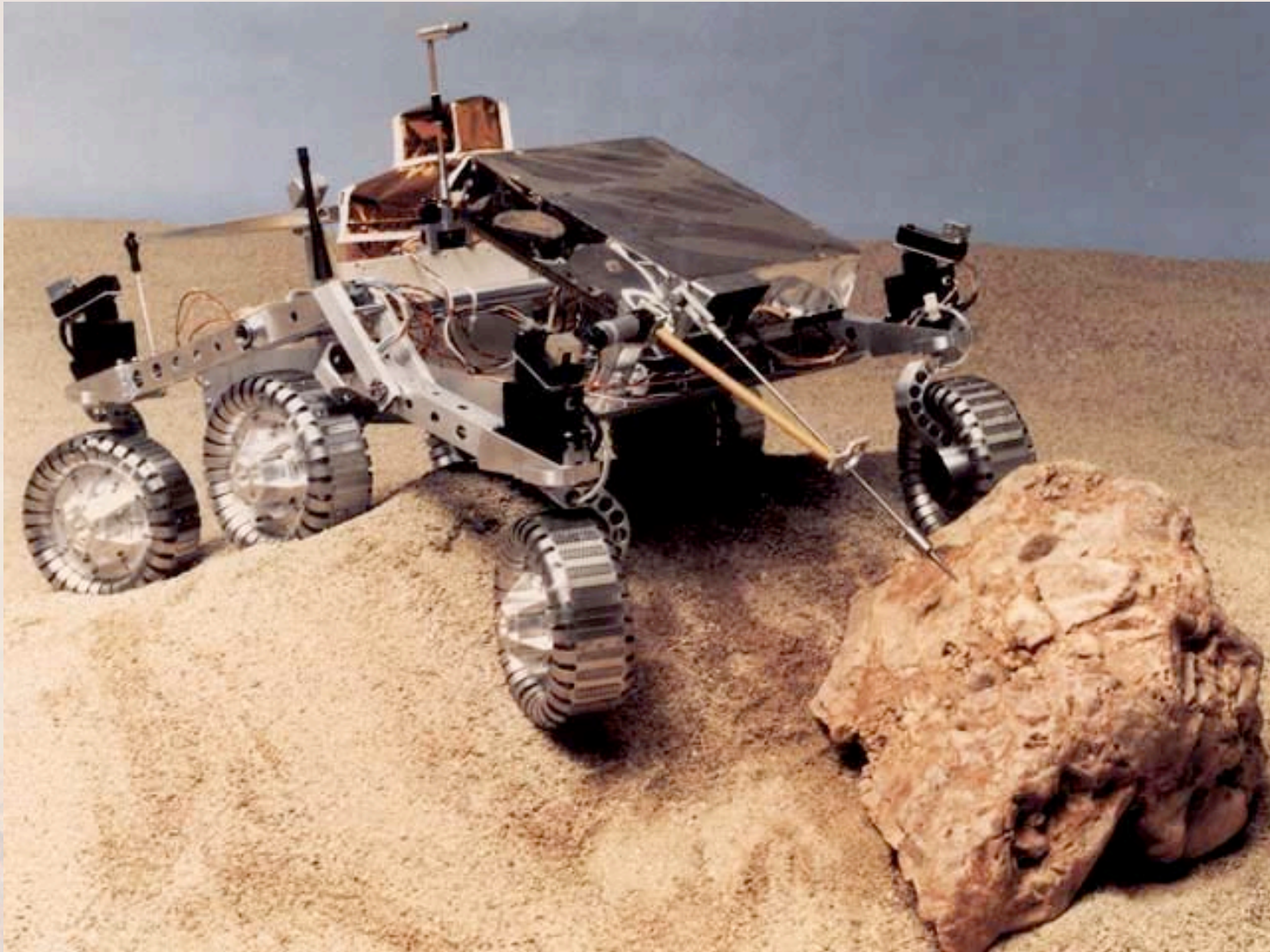

Rocky 7



Sojourner

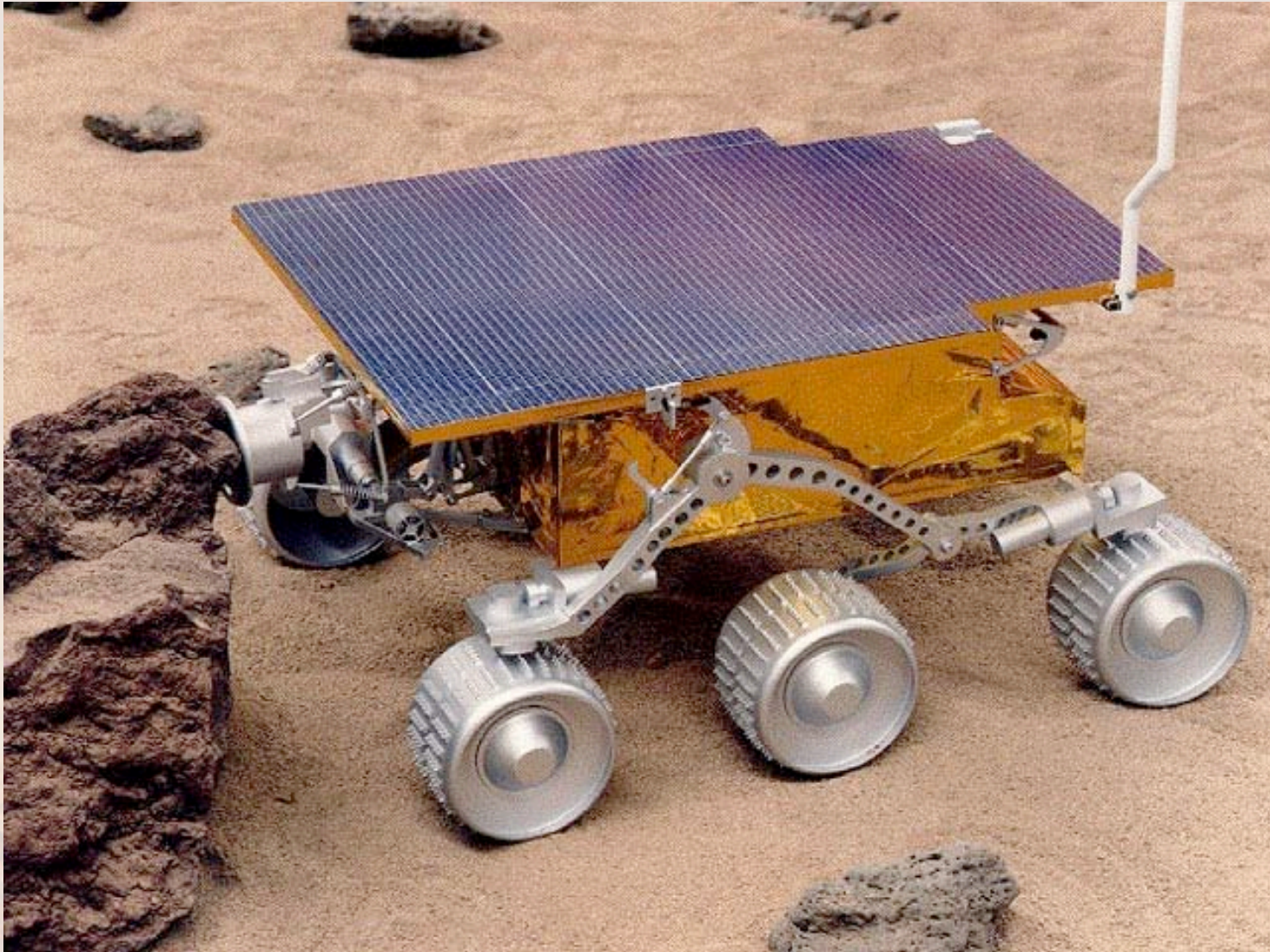

FIDO (JPL)

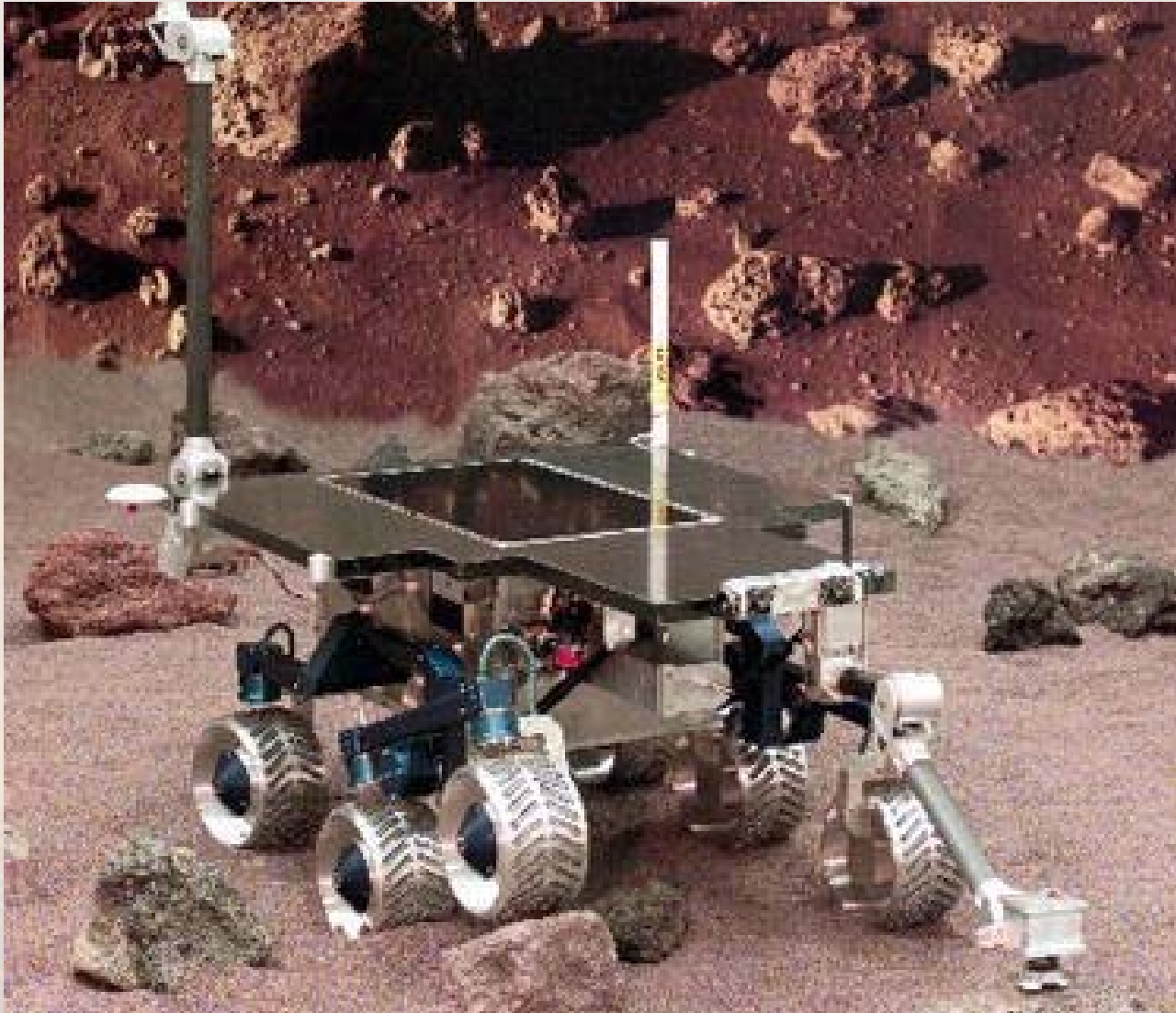

UNIVERSITY OF
MARYLAND

Mars Exploration Rover "Spirit"

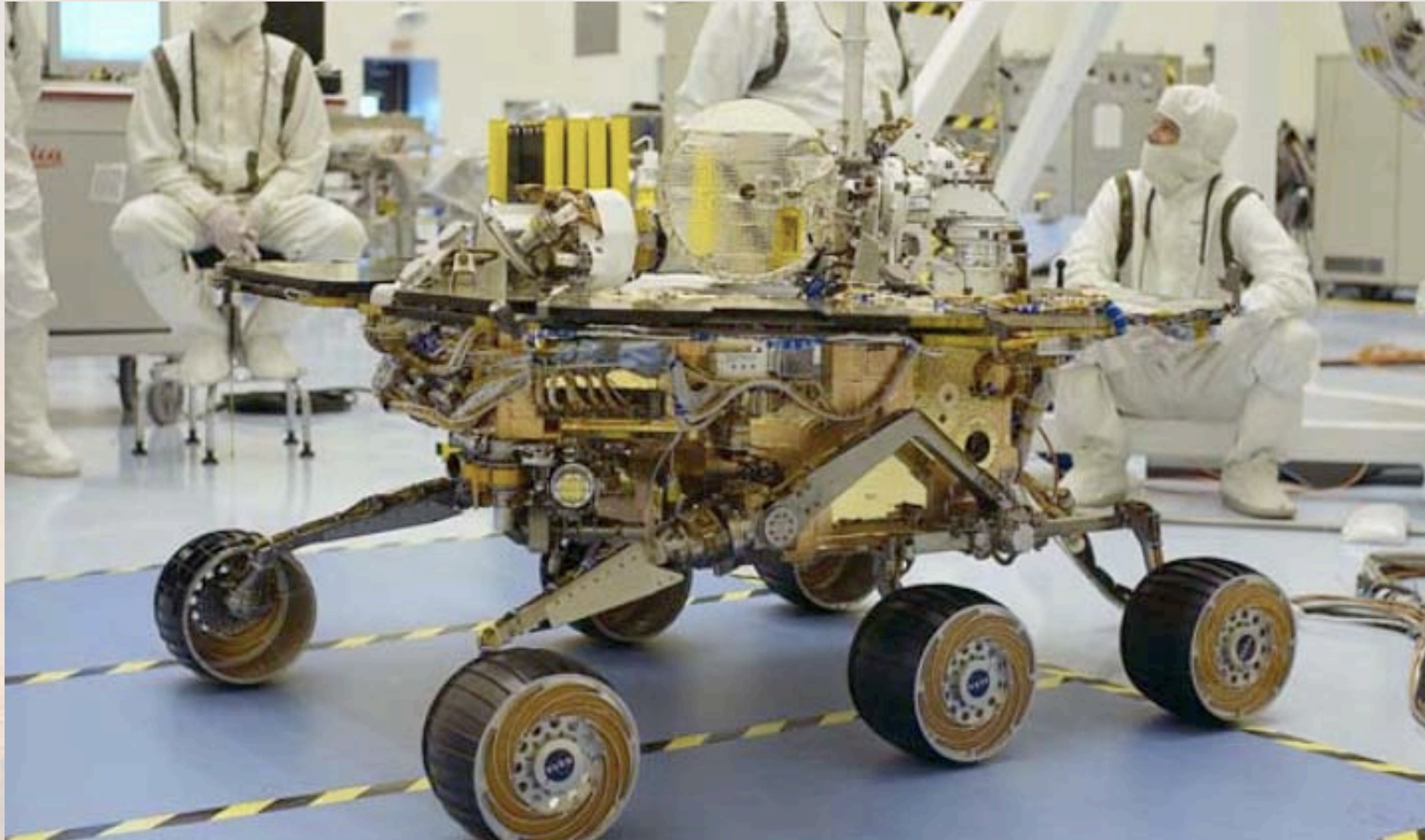

MER Rocker-Bogie Configuration

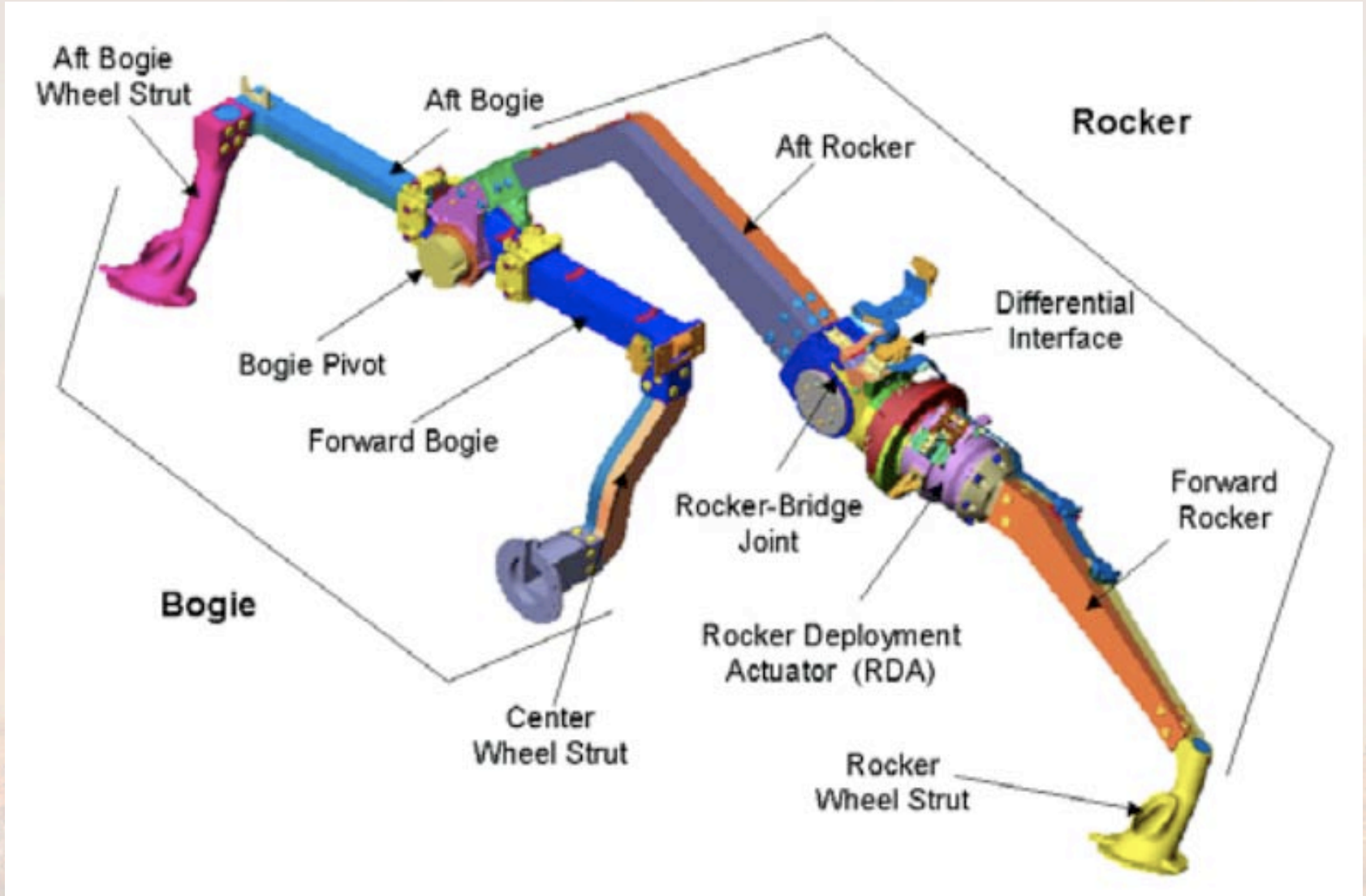

Lightweight Survivable Rover Dimensions

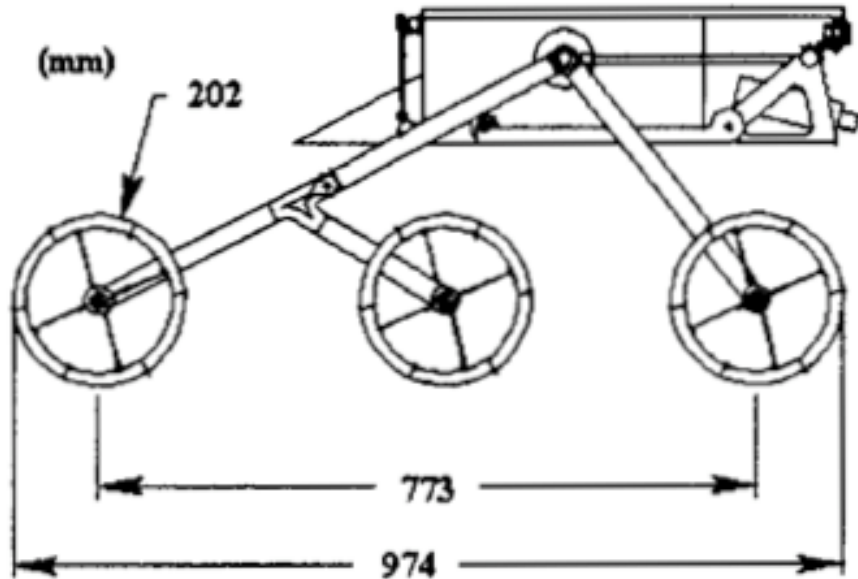

SIDE

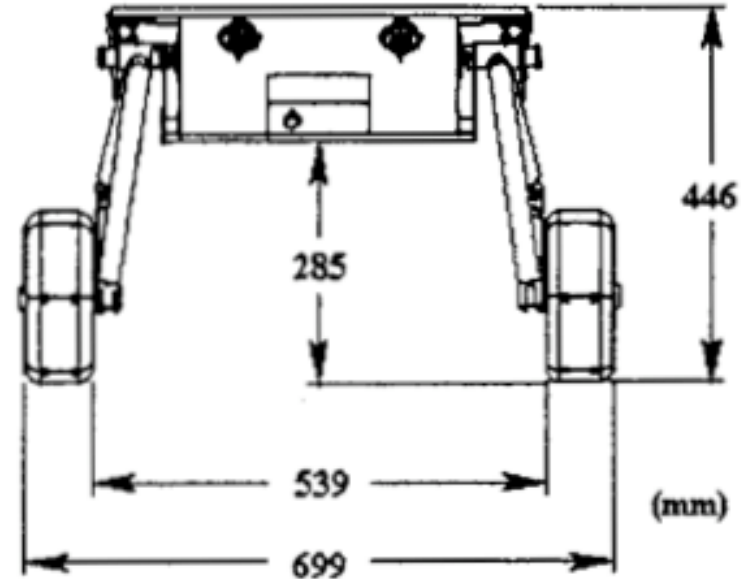

FRONT



Mars Science Laboratory Development Unit



UNIVERSITY OF
MARYLAND

Steering and Suspension Systems
ENAE 788X - Planetary Surface Robotics

MSL Engineering Development Unit



UNIVERSITY OF
MARYLAND

K-Rex Rover (CMU for NASA Ames)



K-Rex Wheel Drive/Steering System

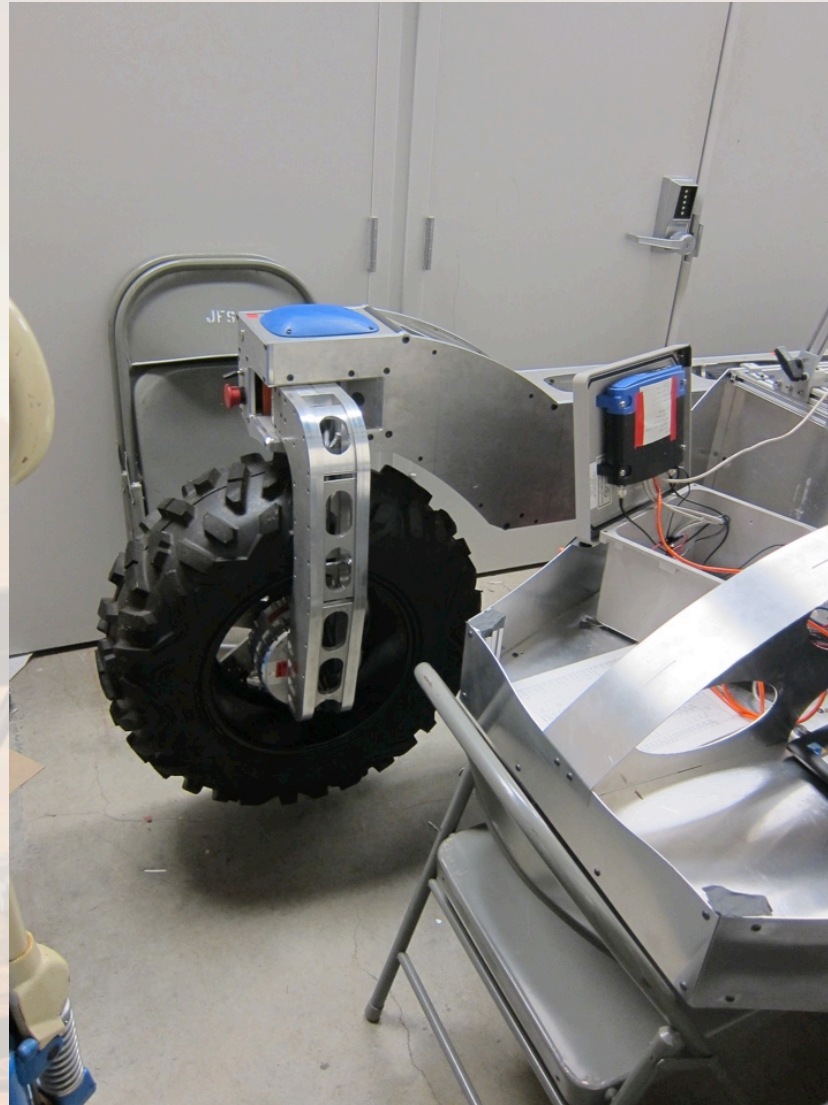

Lunar X-Prize (CMU)

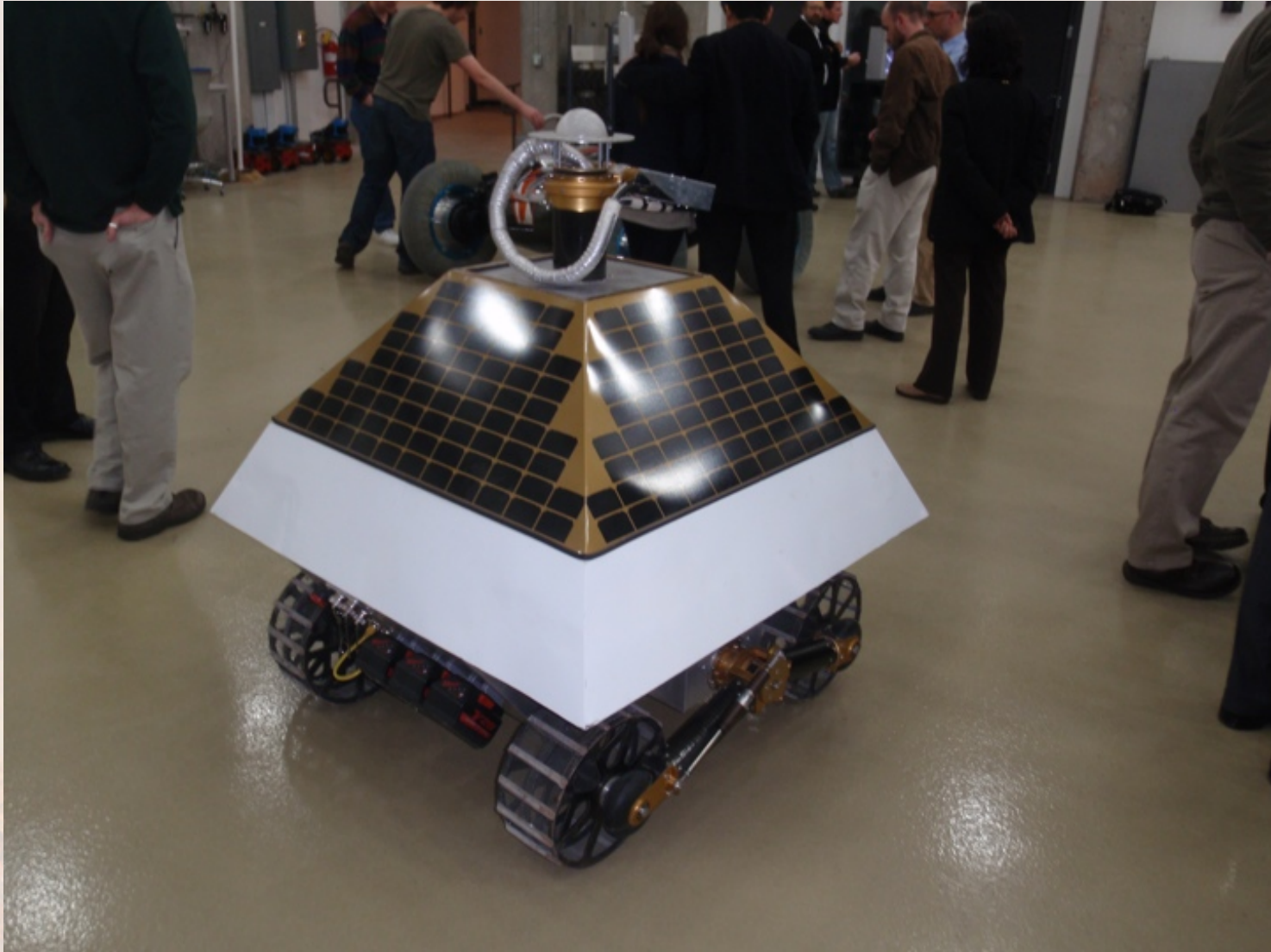

Articulated Bogey Configuration



Segmented Body - Marsokhod

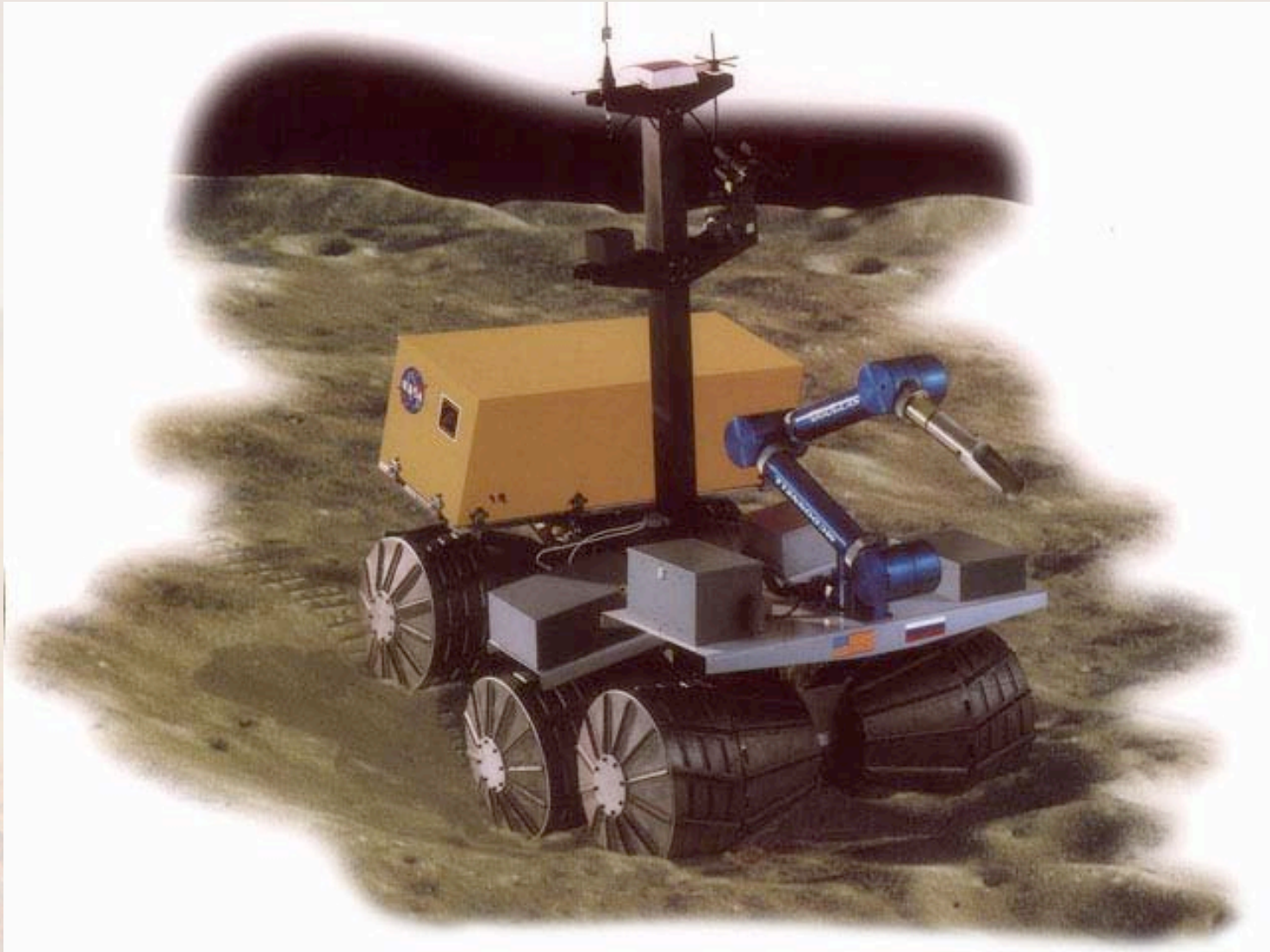

Marsokhod Chassis

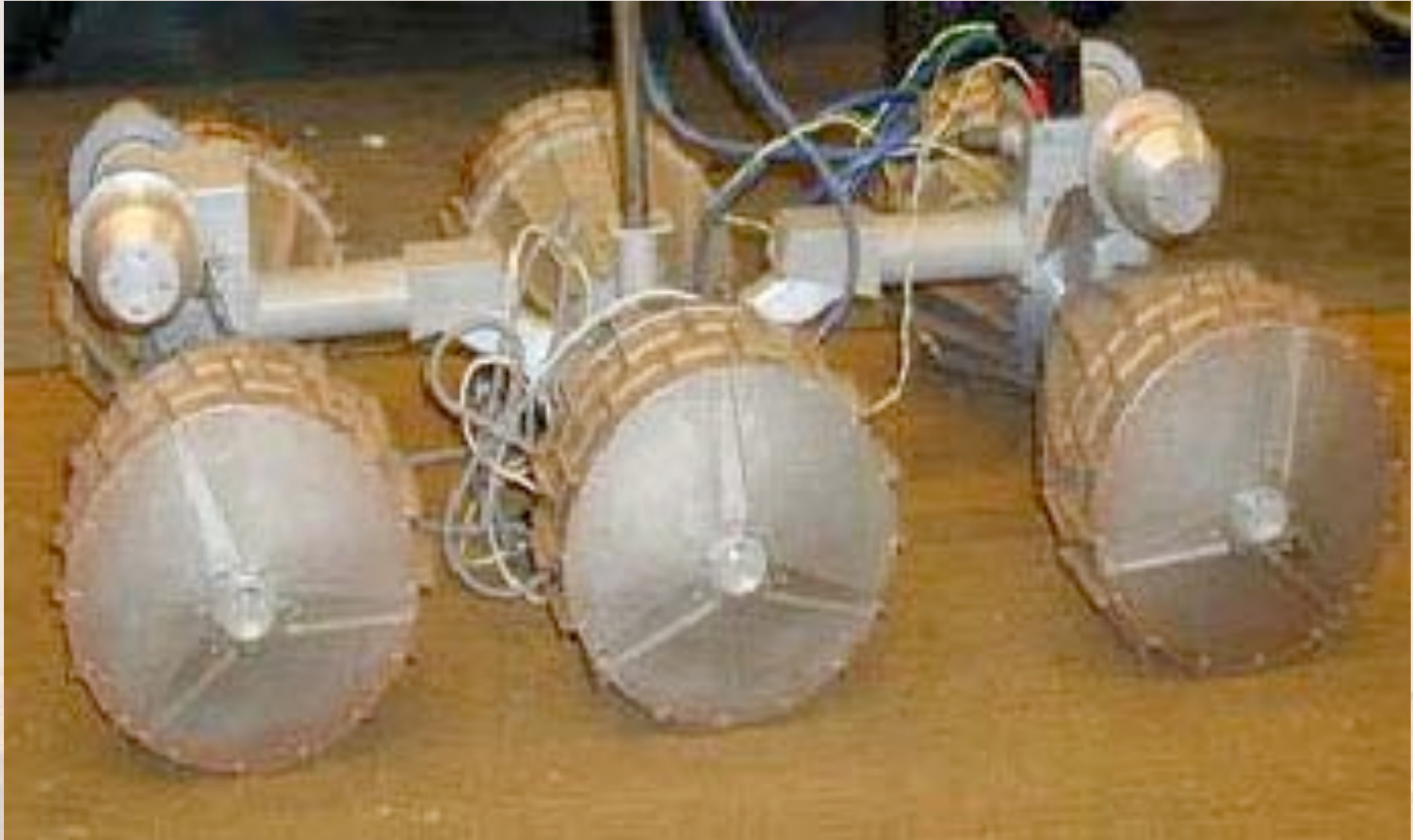

Robby (JPL)



Go-For (JPL)



SCARAB (CMU)



UNIVERSITY OF
MARYLAND

Steering and Suspension Systems
ENAE 788X - Planetary Surface Robotics

Scarab Wheel Articulation (CMU)

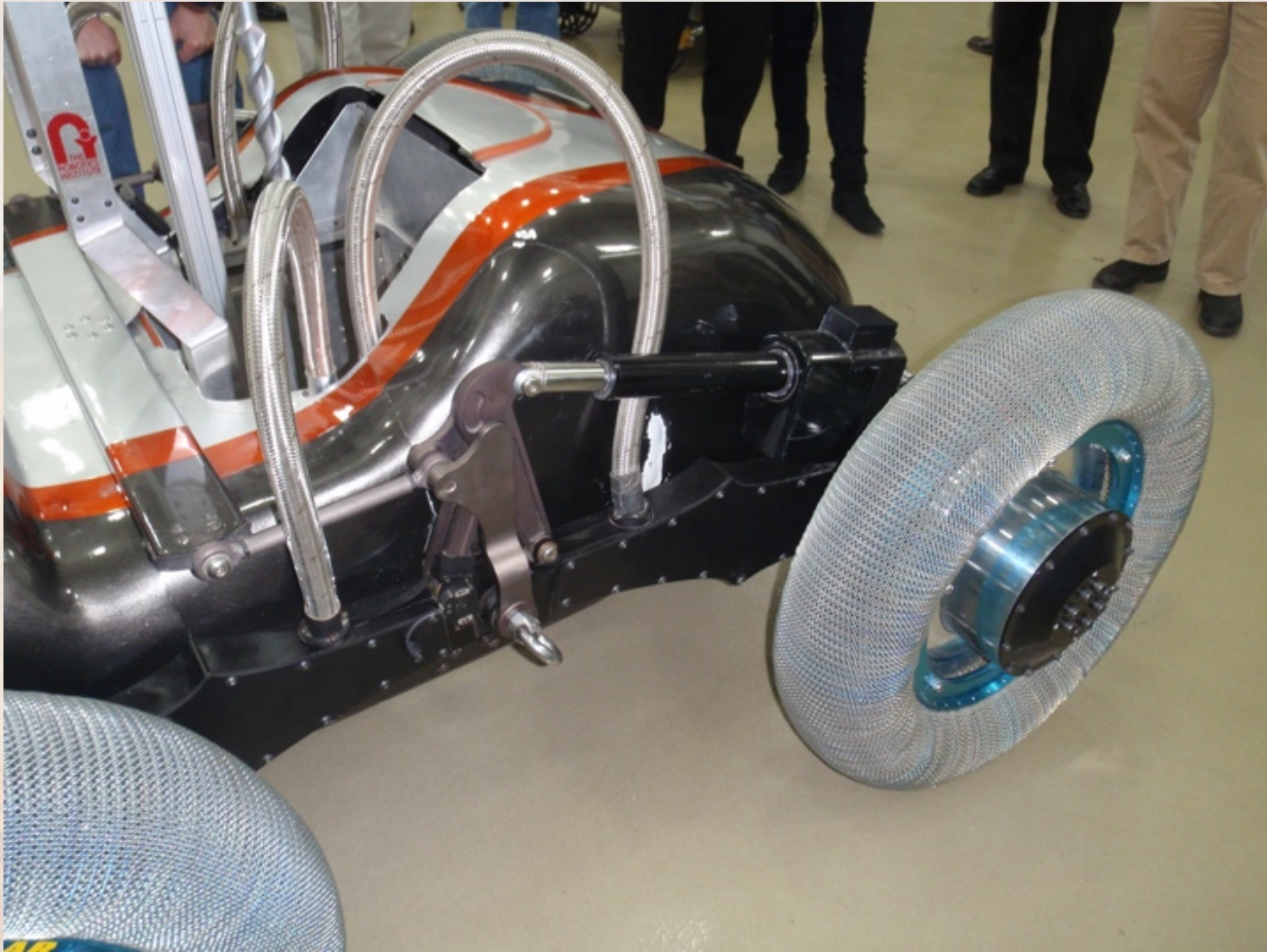

SCARAB at Full Extension (CMU)



UNIVERSITY OF
MARYLAND

Mars Rover (VNIITransmash -



Apollo Lunar Roving Vehicle

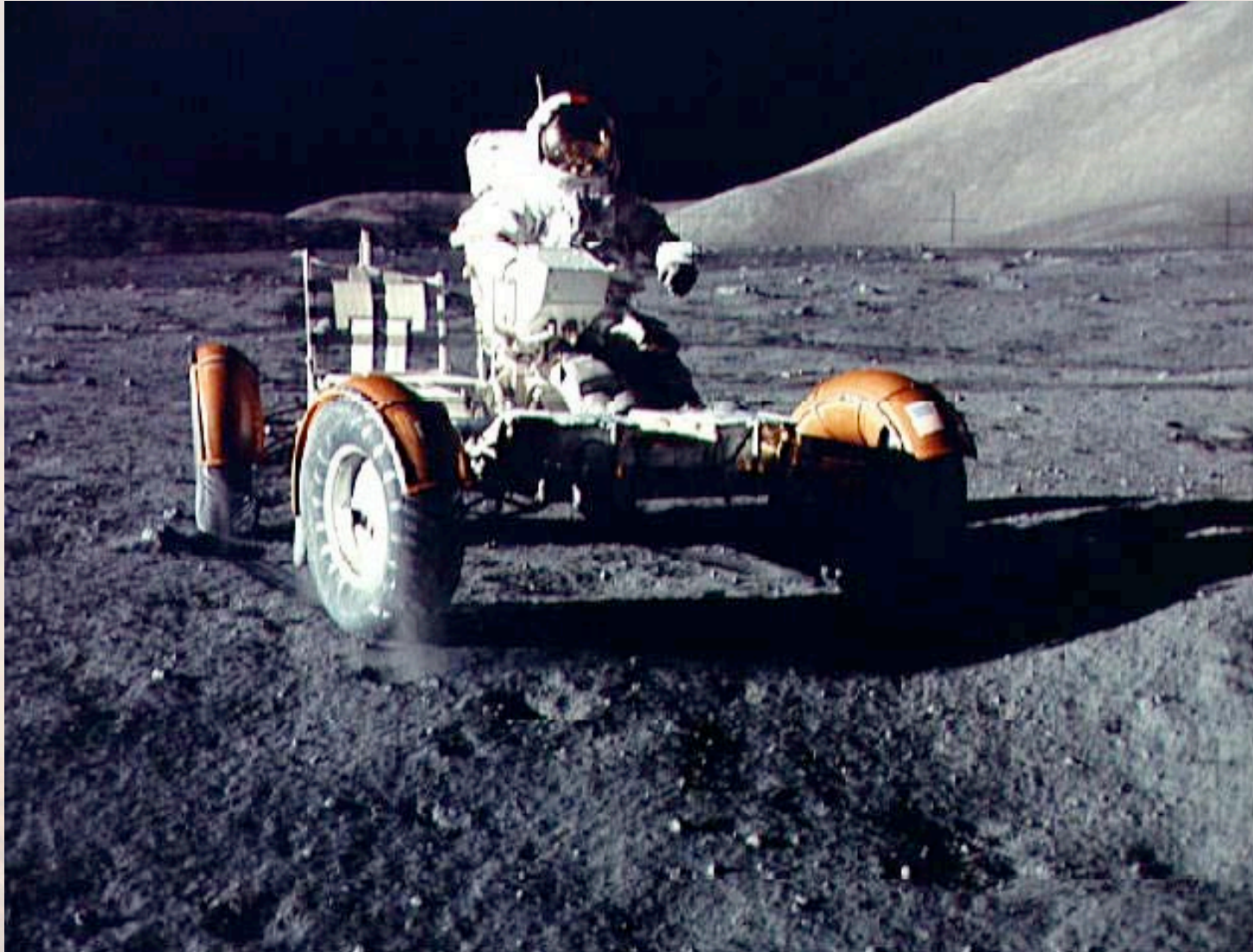

SCOUT Rover (JSC)



UNIVERSITY OF
MARYLAND

Steering and Suspension Systems
ENAE 788X - Planetary Surface Robotics

Electric Tractor and Chariot (JSC)



Active Suspension - Chariot



Chariot B Climbs a Boulder Field



RAVEN in Field Trials



UNIVERSITY OF
MARYLAND

Steering and Suspension Systems
ENAE 788X - Planetary Surface Robotics

SEV Driving Onto $\sim 20^\circ$ Slope



SEV on $\sim 20^\circ$ Slope



SEV Dual Bogie Soil Contact



UNIVERSITY OF
MARYLAND

ATHLETE (JPL)



UNIVERSITY OF
MARYLAND

Centaur with Robonaut (JSC)



Centaur Body Pose and Turning



Palm Pilot Robot (CMU)(Holonomic)



Tessellator (CMU) (Holonomic)

