

# Steering and Suspension Systems

- Steering Systems
  - Skid-Steer
  - Differential drive
  - Trailer steering
  - Ackerman steering
  - Actively controlled steering (Independent/explicit)
  - Holonomic vs. Nonholonomic Systems
- Suspension Systems
  - Rigid Suspension
  - Independent Suspension
  - Articulated / Split-Body Suspension
  - Rocker-Bogie Configurations
  - Segmented-Body Rovers
  - Active Suspension

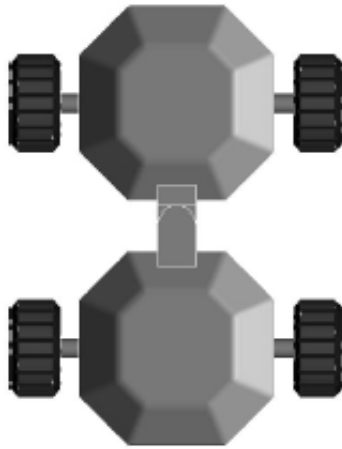

# Steering Schemes



ARTICULATED

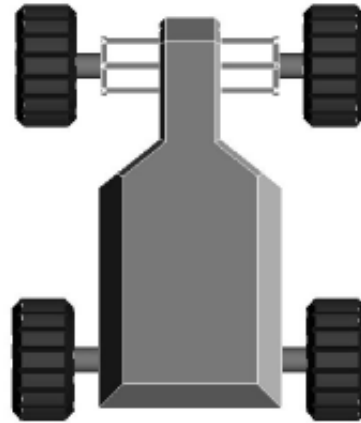

COORDINATED  
(Ackermann Type)

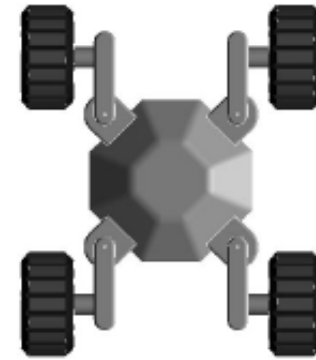

INDEPENDENT  
EXPLICIT

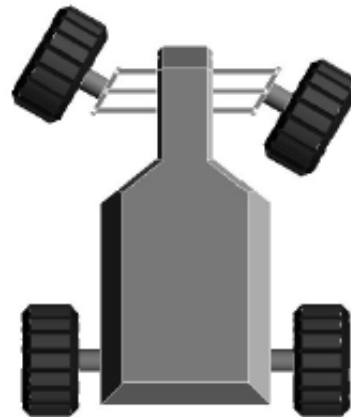
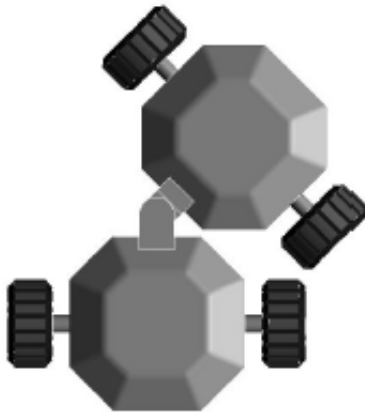

# Fixed Suspension - Electric Tractor (JSC)



# ET "Suspension"



# Fixed Suspension in Hilly Terrain



# ATRV Skid-Steer Robots



# Laboratory Robot (CMU)



# Laboratory Robot (CMU)





# RAVEN (UMd/ASU)



UNIVERSITY OF  
MARYLAND

# RAVEN in Mobility Testing



UNIVERSITY OF  
MARYLAND

# Tooth (JPL) - Ackerman Steering



# Hyperion (CMU)



# Hyperion (CMU) - Trailer Steering



# Independent Suspension (Towed Vehicle)

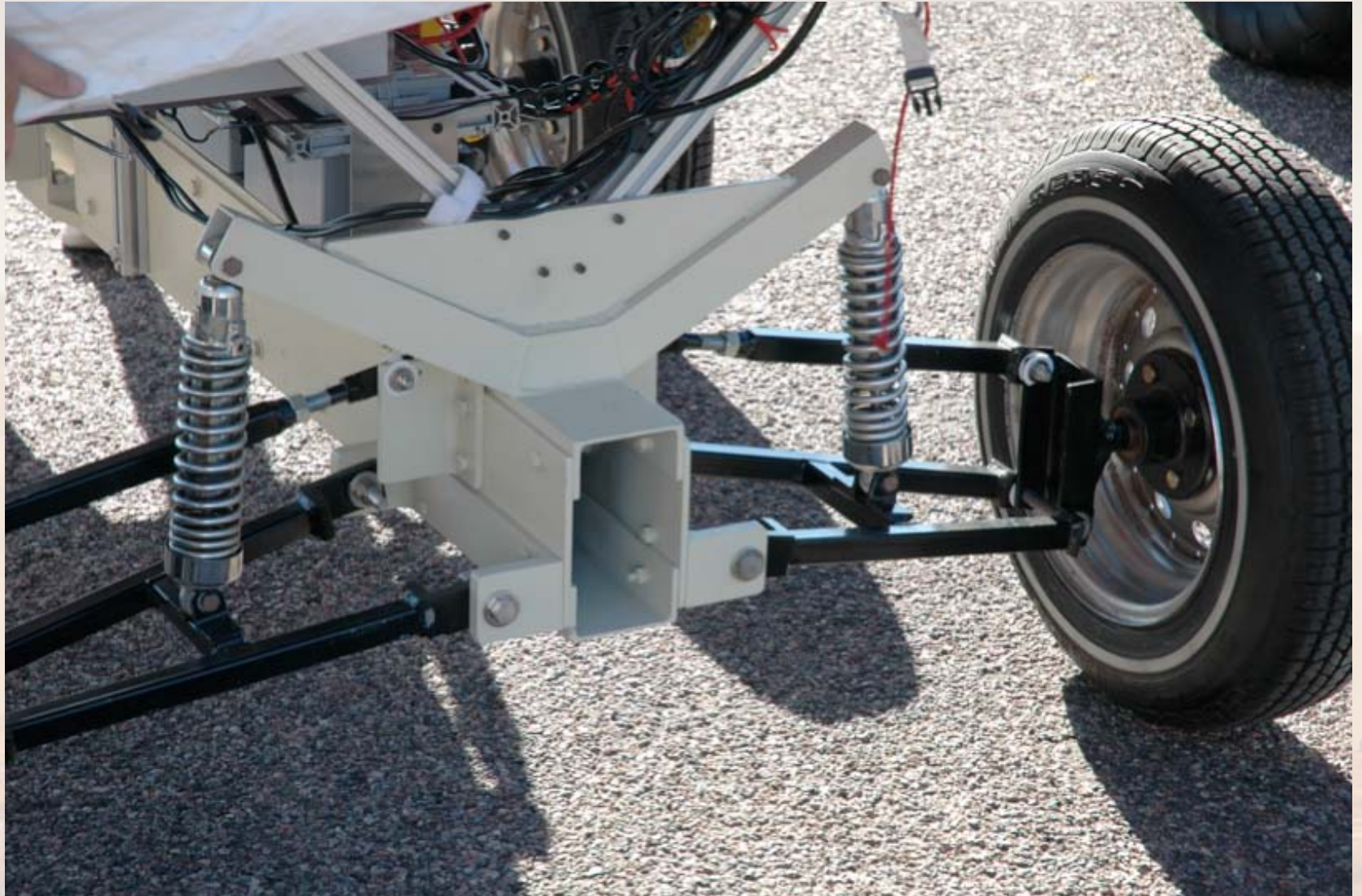

# SCOUT Astronaut Support Rover (JSC)



UNIVERSITY OF  
MARYLAND

# SCOUT Suspension and Steering





# Articulating Suspension - Nomad (CMU)



UNIVERSITY OF  
MARYLAND

# Nomad Transforming Chassis

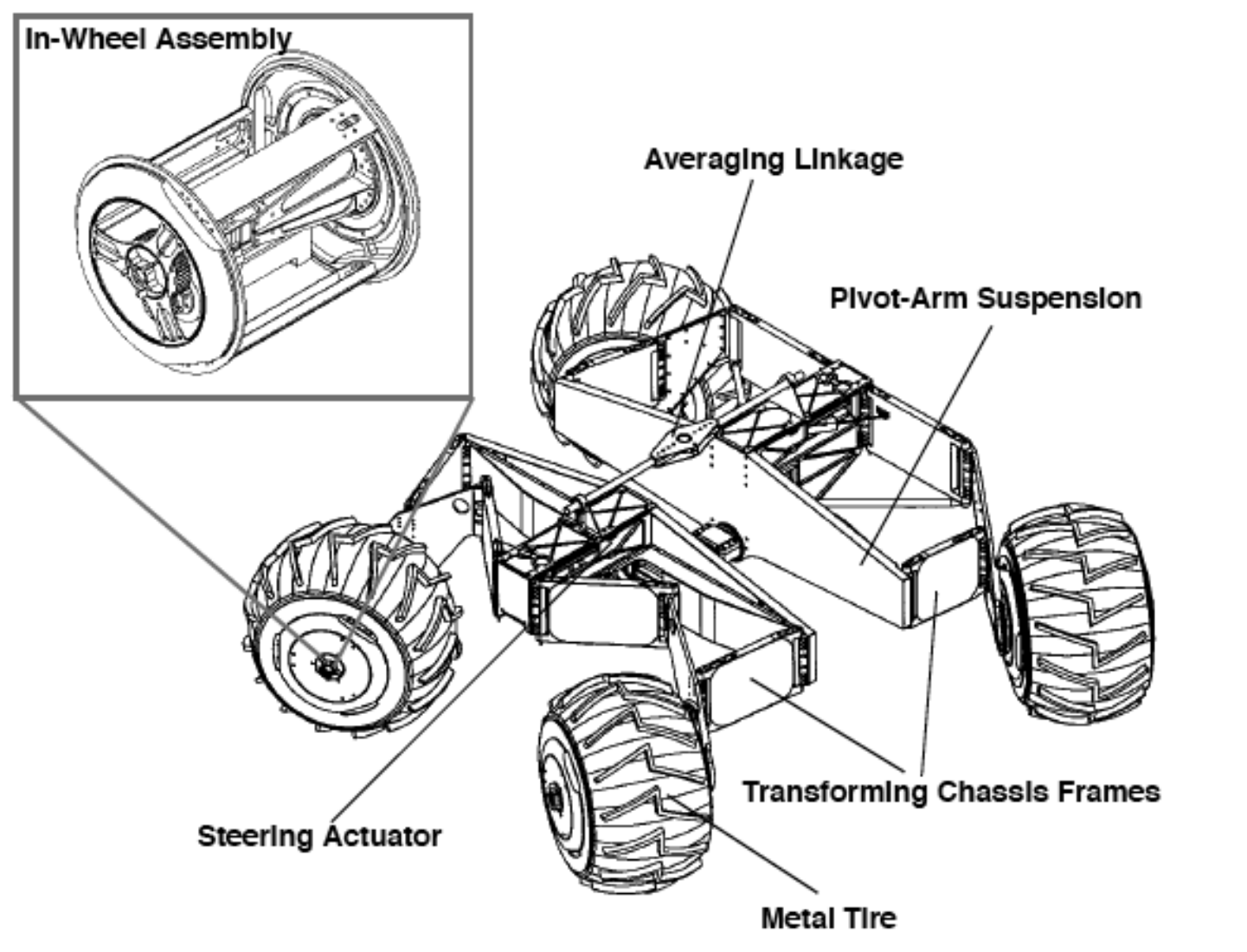

# Nomad in Rough Terrain



UNIVERSITY OF  
MARYLAND

# Nomad Chassis/Steering System

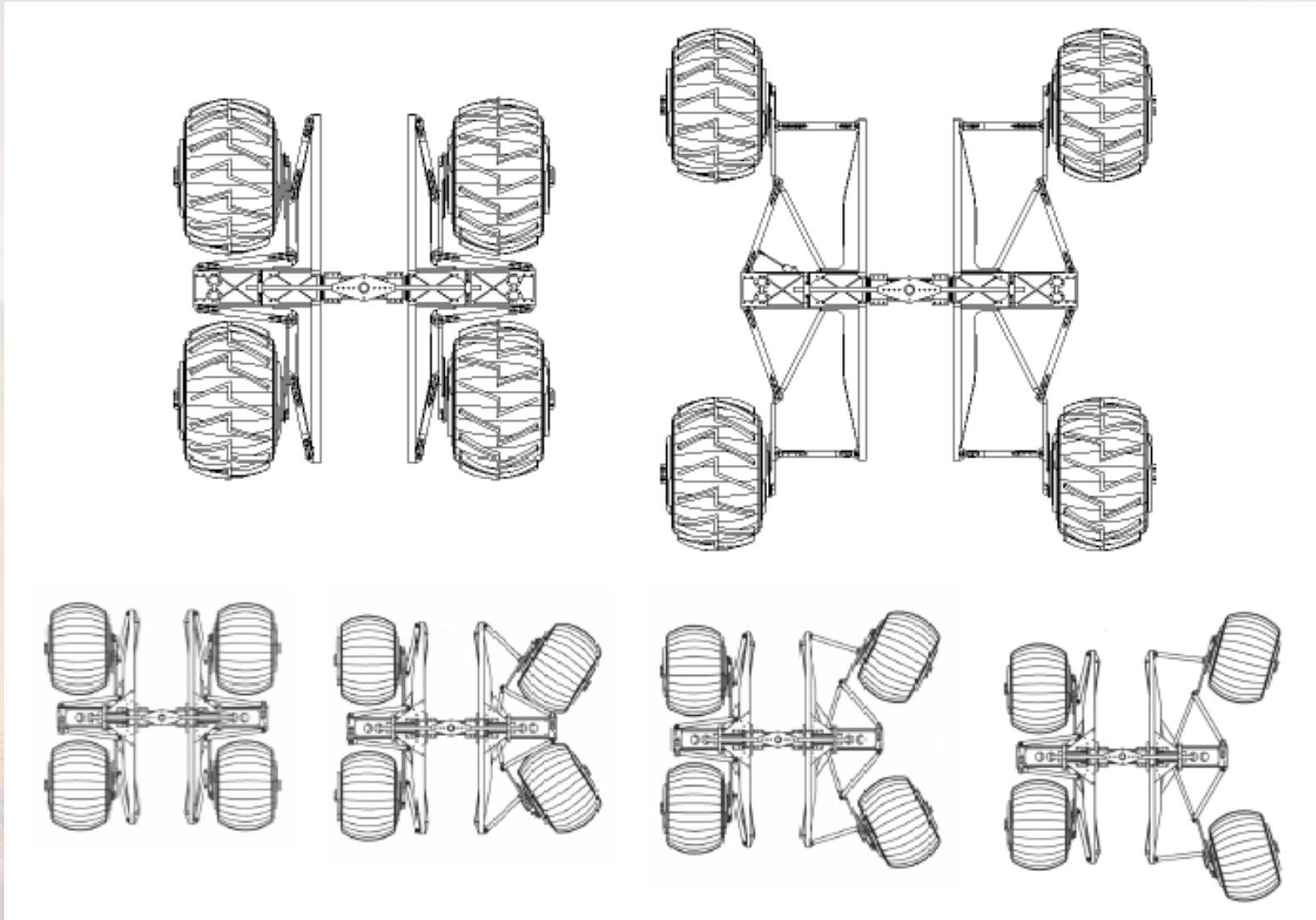

# Nomad with Wheels Stowed



# Nomad Steering Schemes

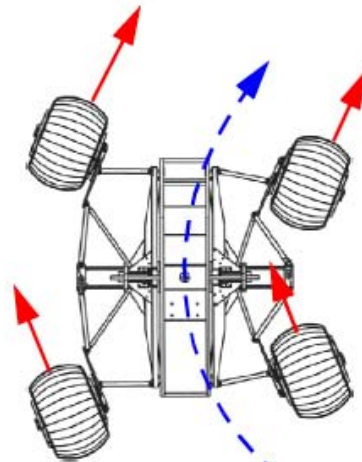

Dual Ackermann

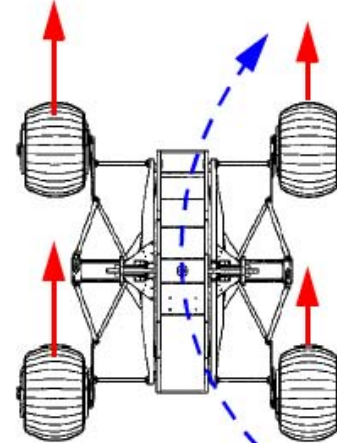

Differential Skid Steering

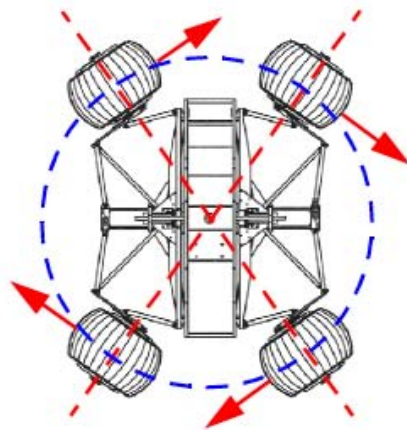

Rolling Point Turn

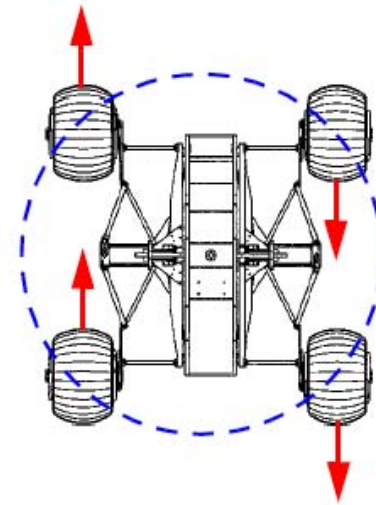

Skid Steering Point Turn



# Nomad Power in Skid and Explicit Turns

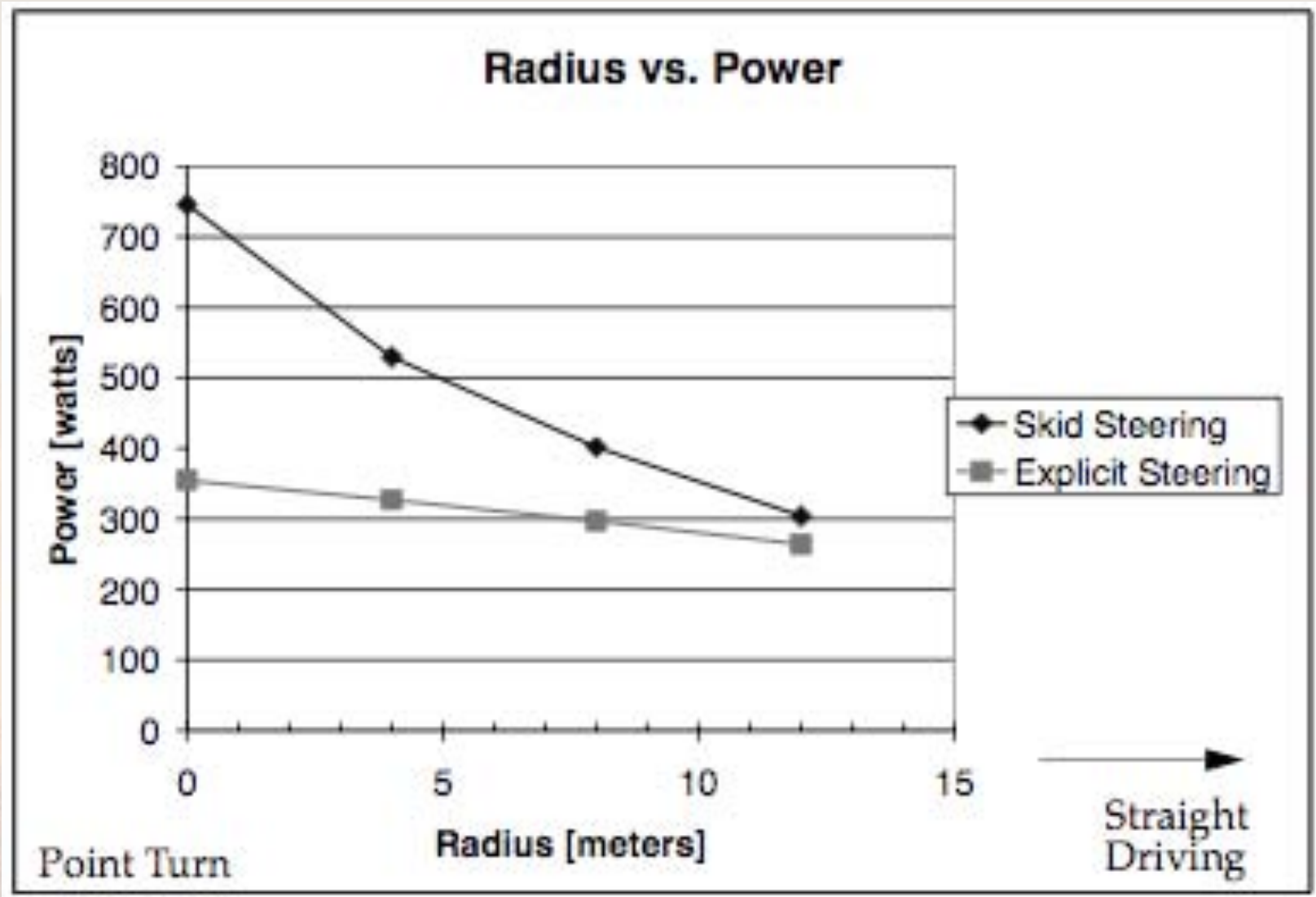

# Steering Power Comparison with Fixed Loads

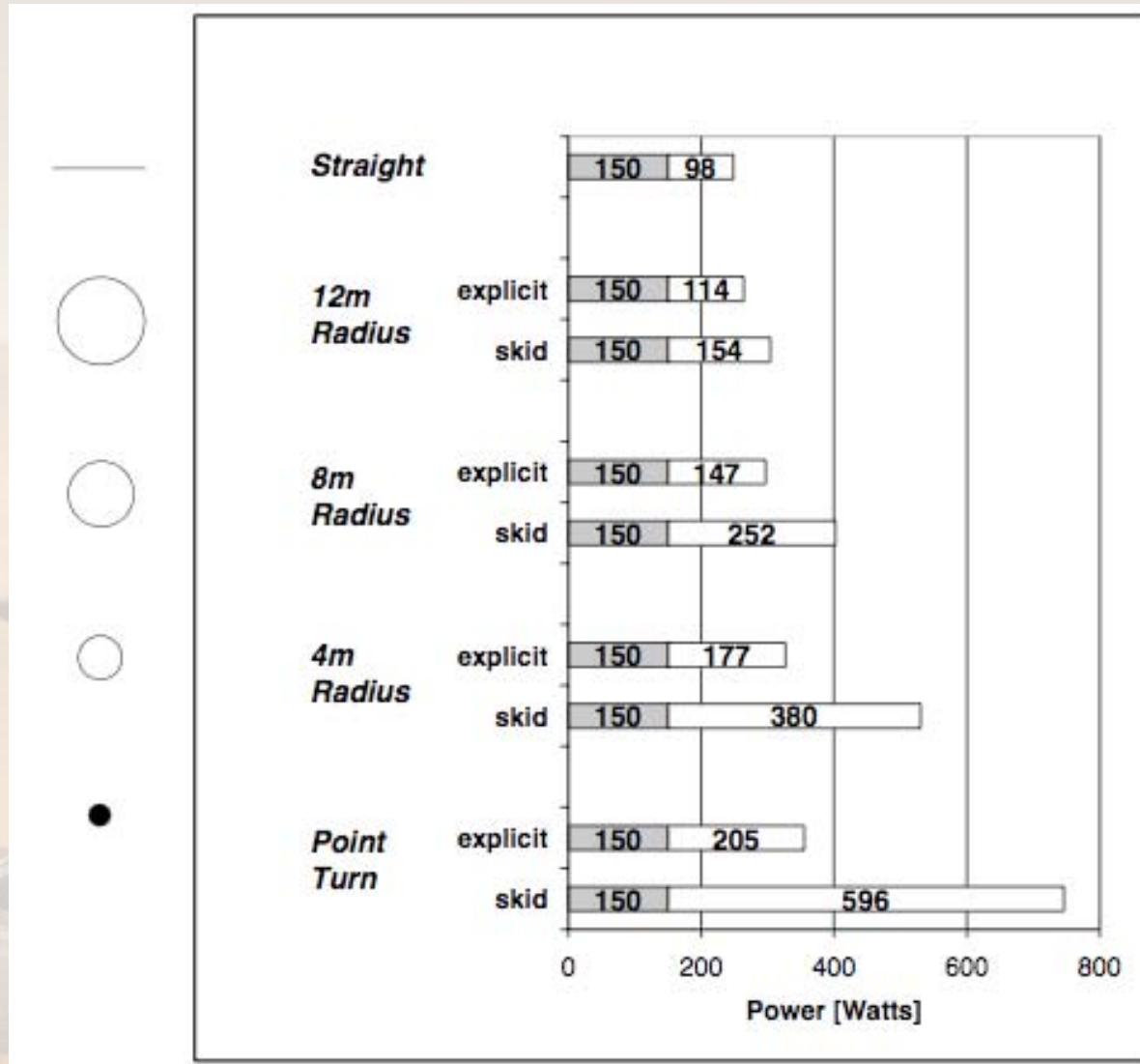



# Nomad Wheel Torques in Skid Turn

% of total torque contribution by each wheel for 4m radius skid steering turns

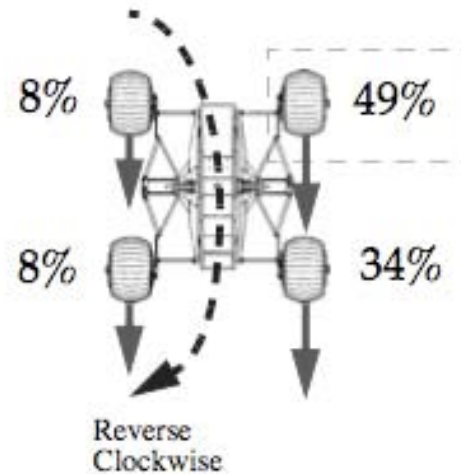
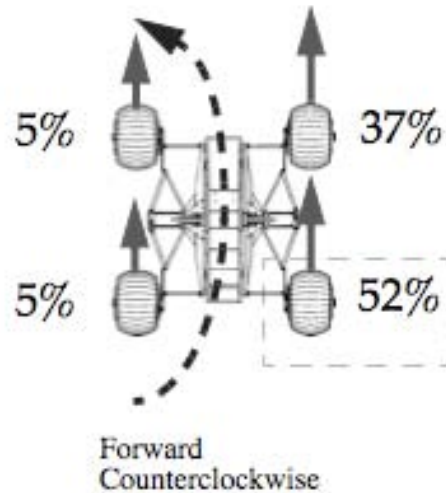
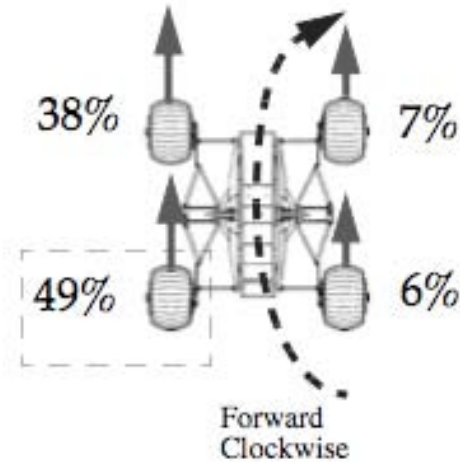

# Split-Body Rovers (Sandia Labs)

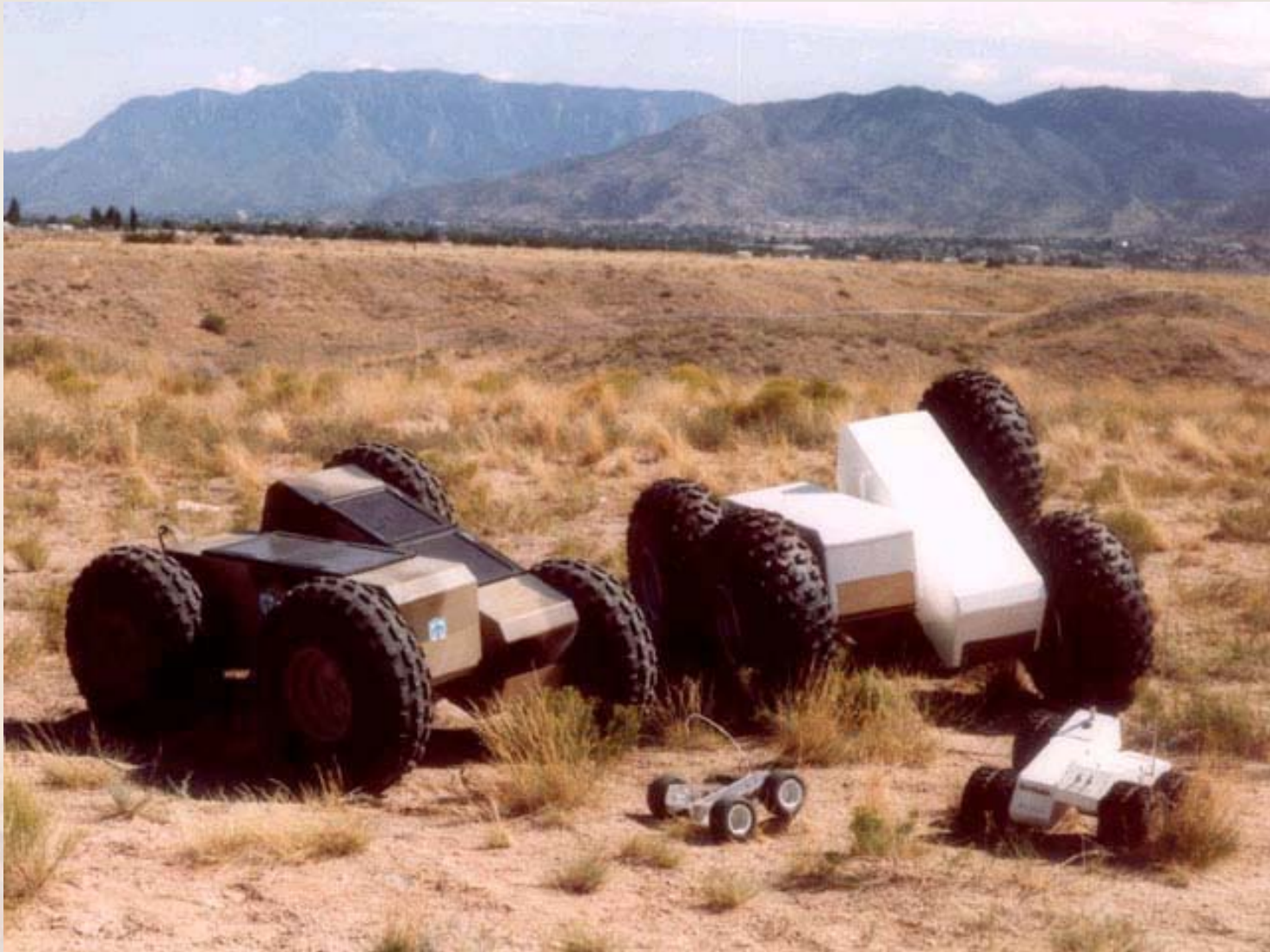

# Ratler (Sandia Labs)



# Rocker-Bogie - Rocky 4



# Rocky 7



# Sojourner

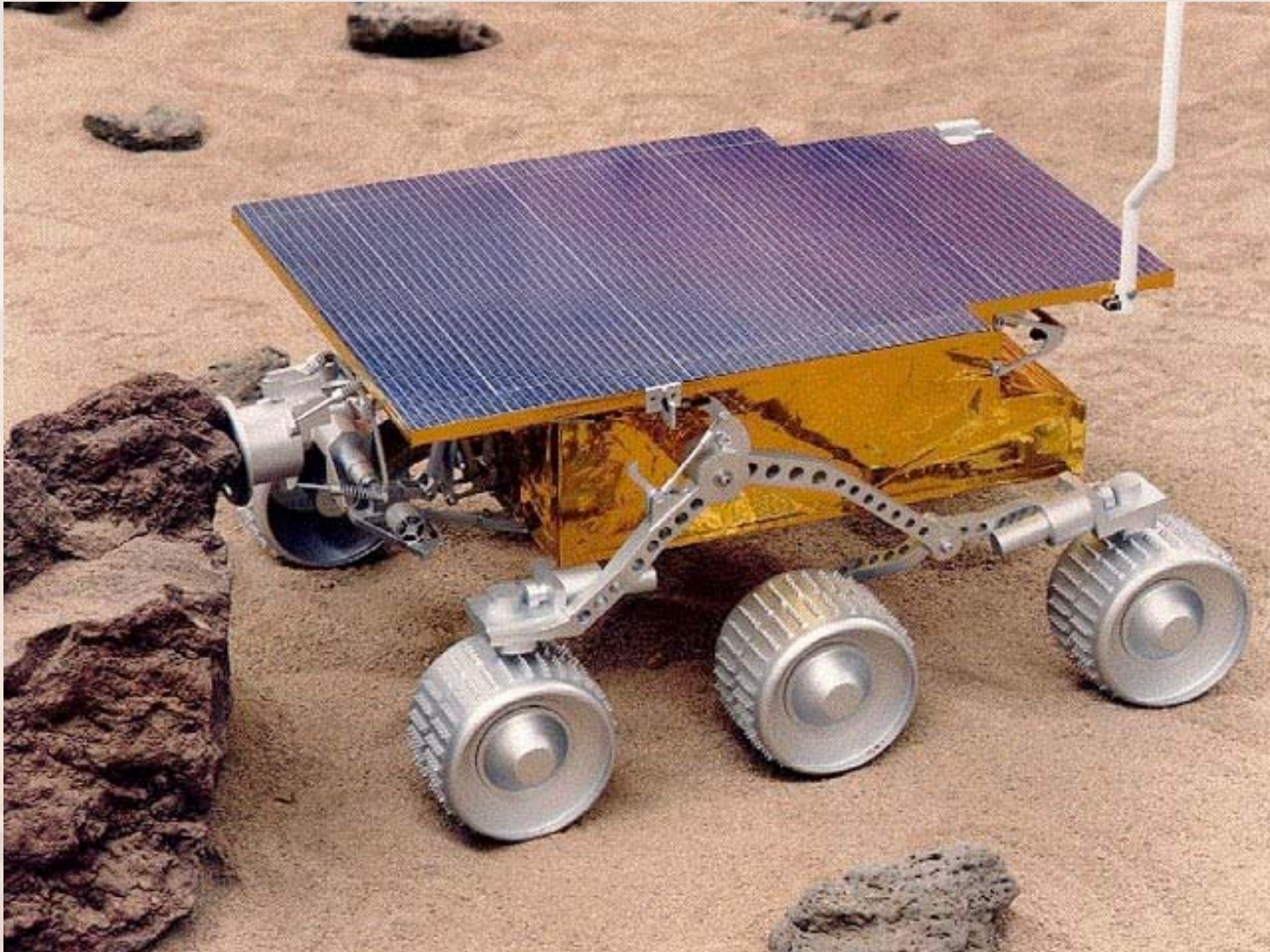

# FIDO (JPL)

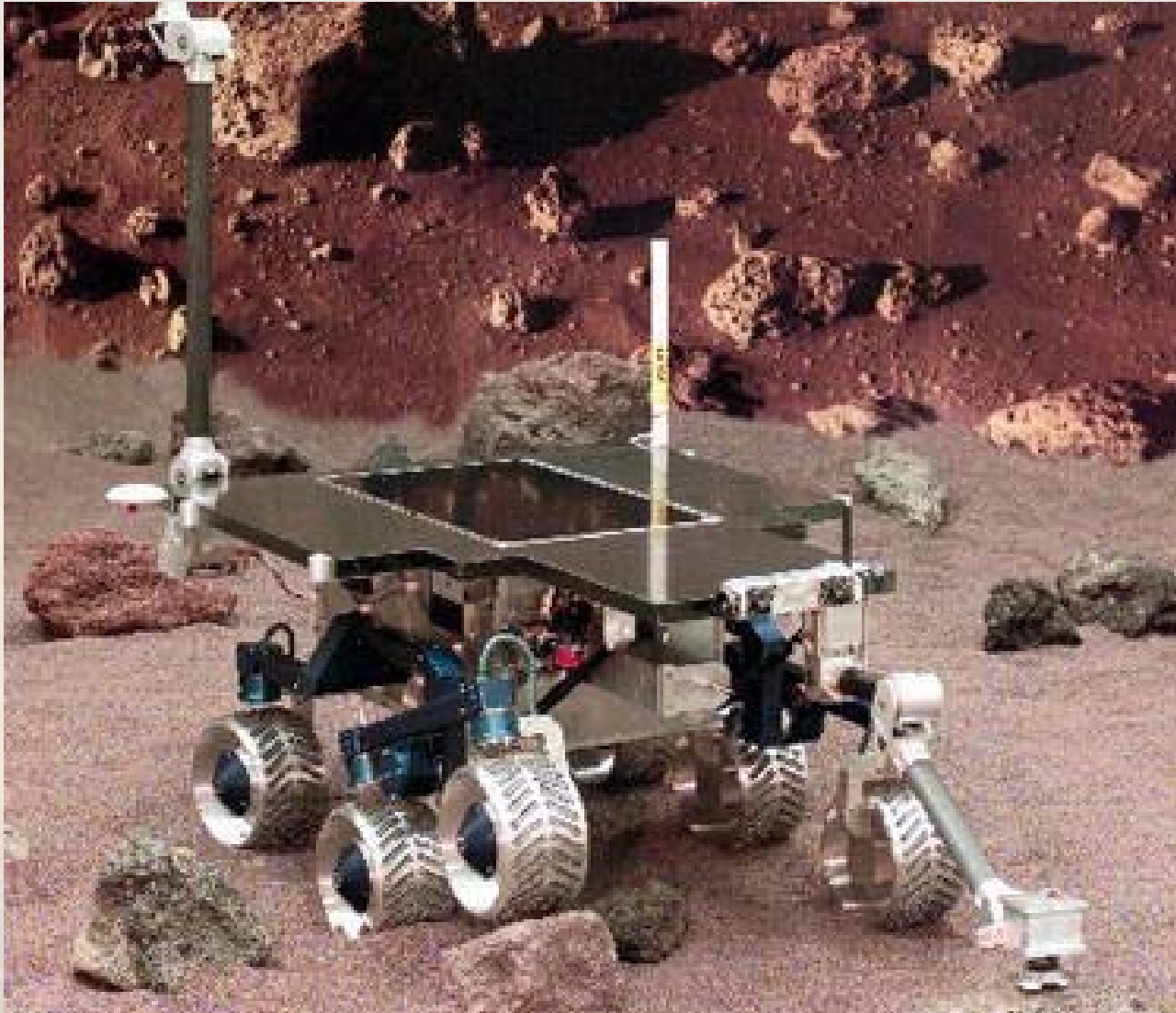

UNIVERSITY OF  
MARYLAND

# Mars Exploration Rover "Spirit"

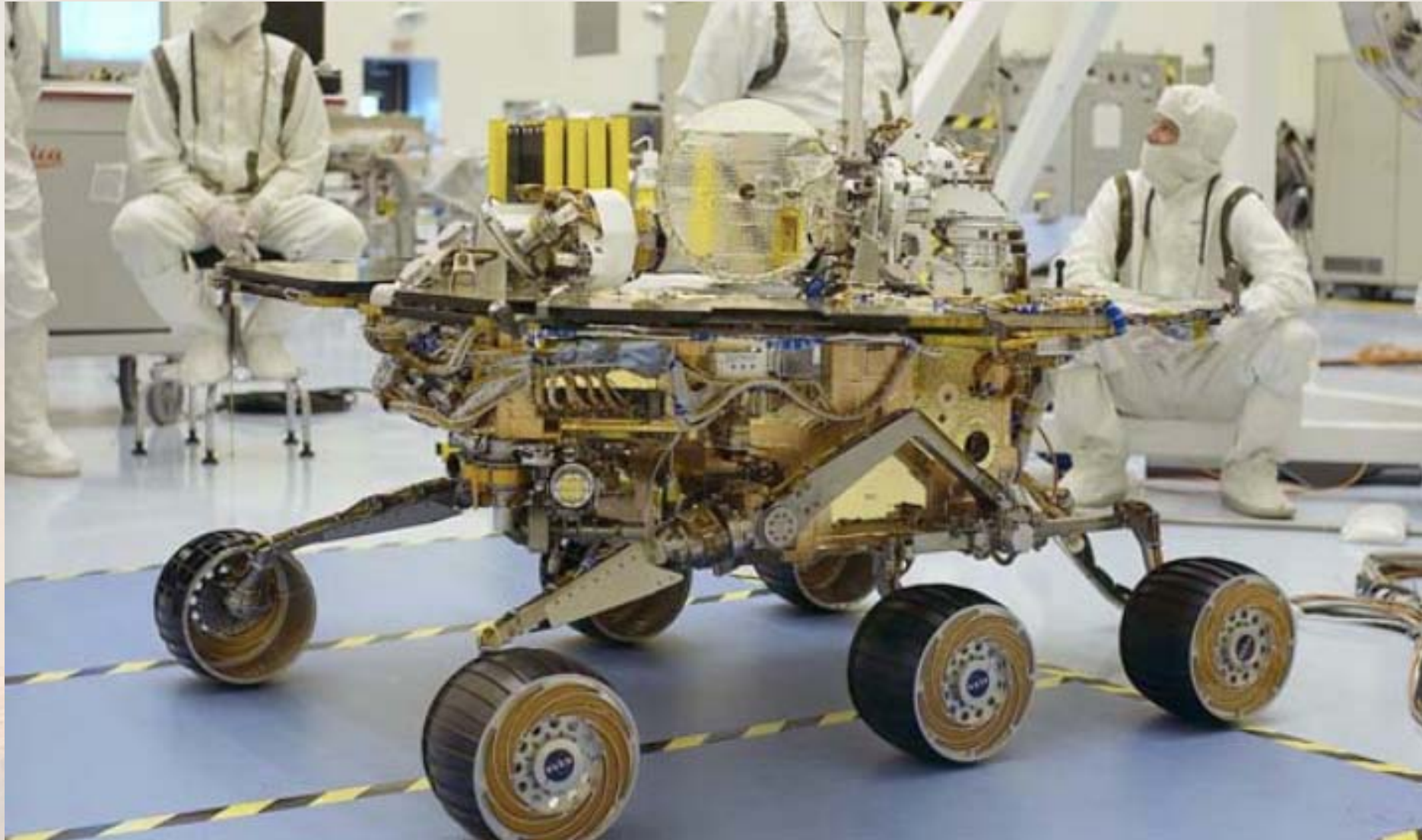



# MER Rocker-Bogie Configuration

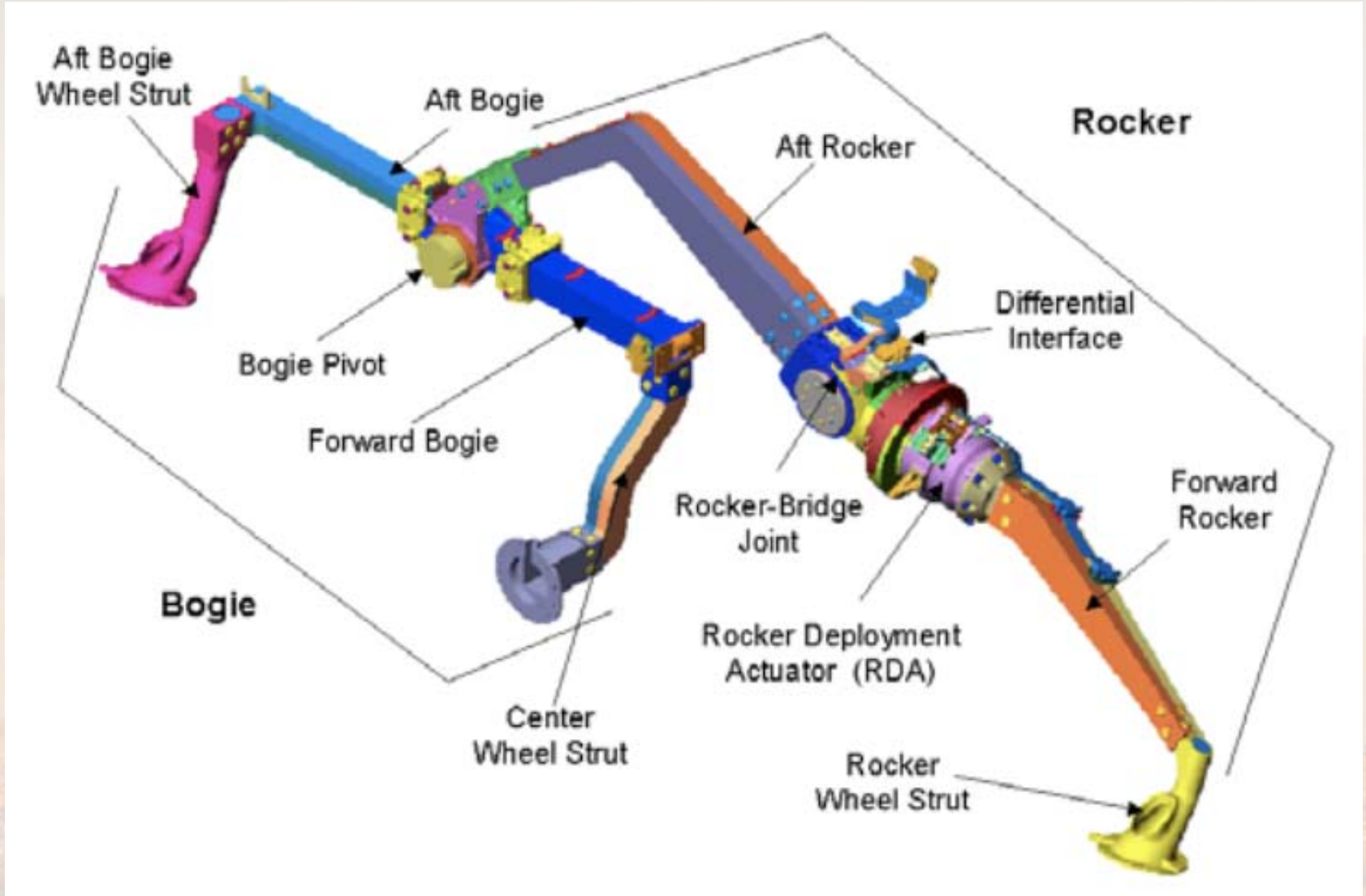

# Lightweight Survivable Rover Dimensions

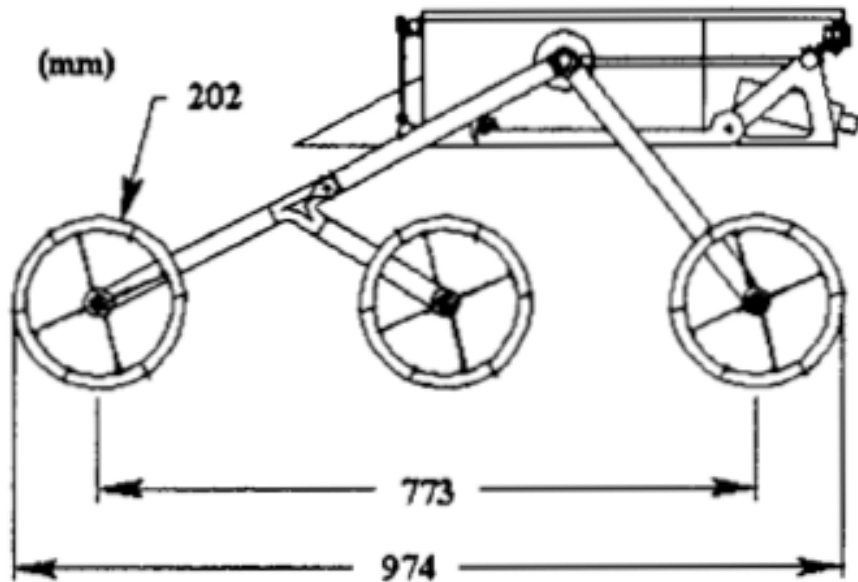

**SIDE**

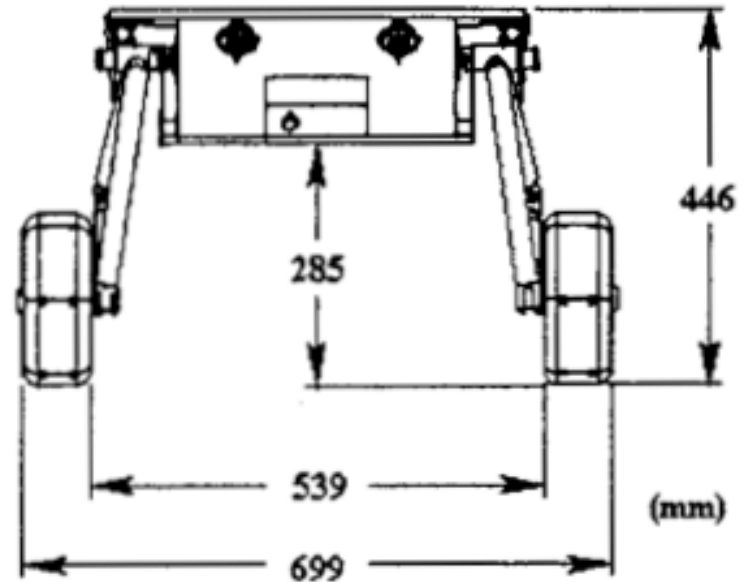

**FRONT**



# Mars Science Laboratory Development Unit



UNIVERSITY OF  
MARYLAND

# MSL Engineering Development Unit



UNIVERSITY OF  
MARYLAND

# K-Rex Rover (CMU for NASA Ames)

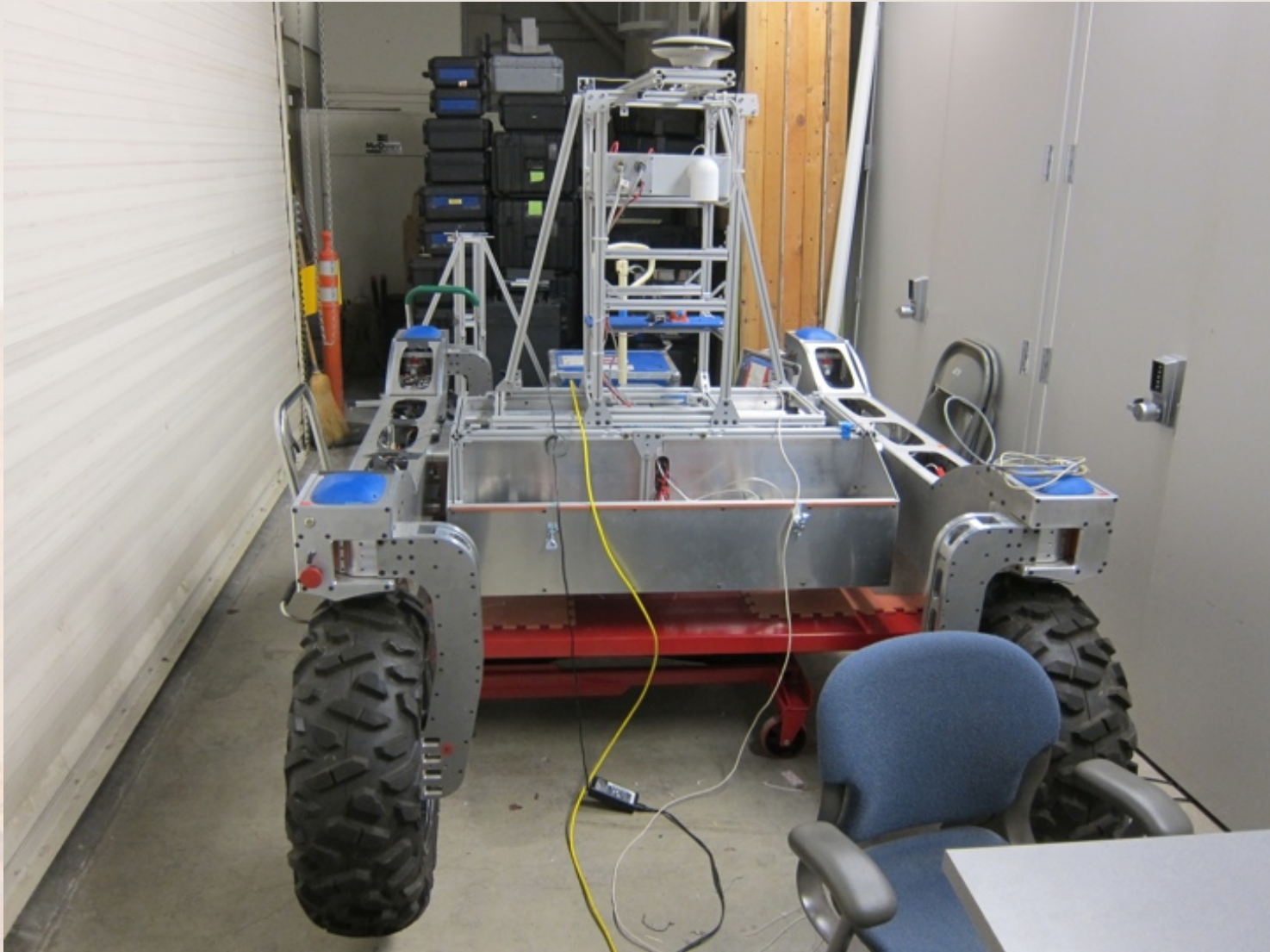

# K-Rex Wheel Drive/Steering System

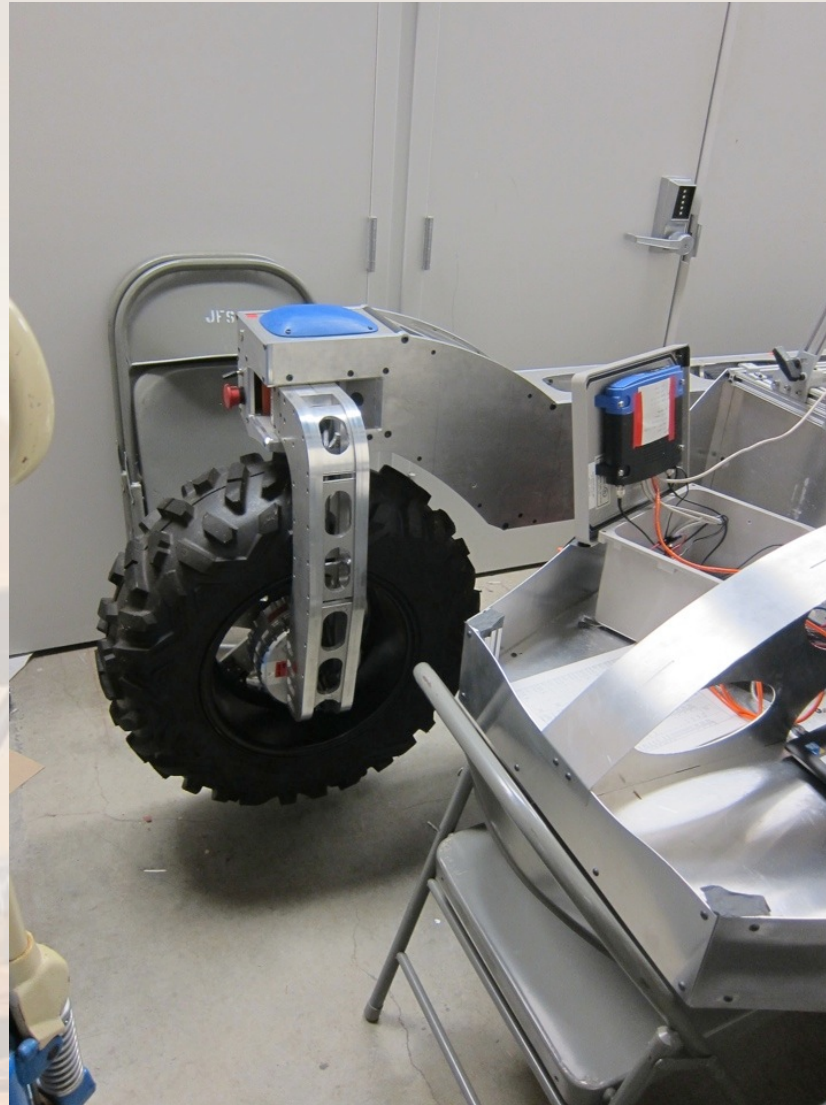

# Revised K-Rex Rover (NASA Ames)



# K-Rex Differential Bar

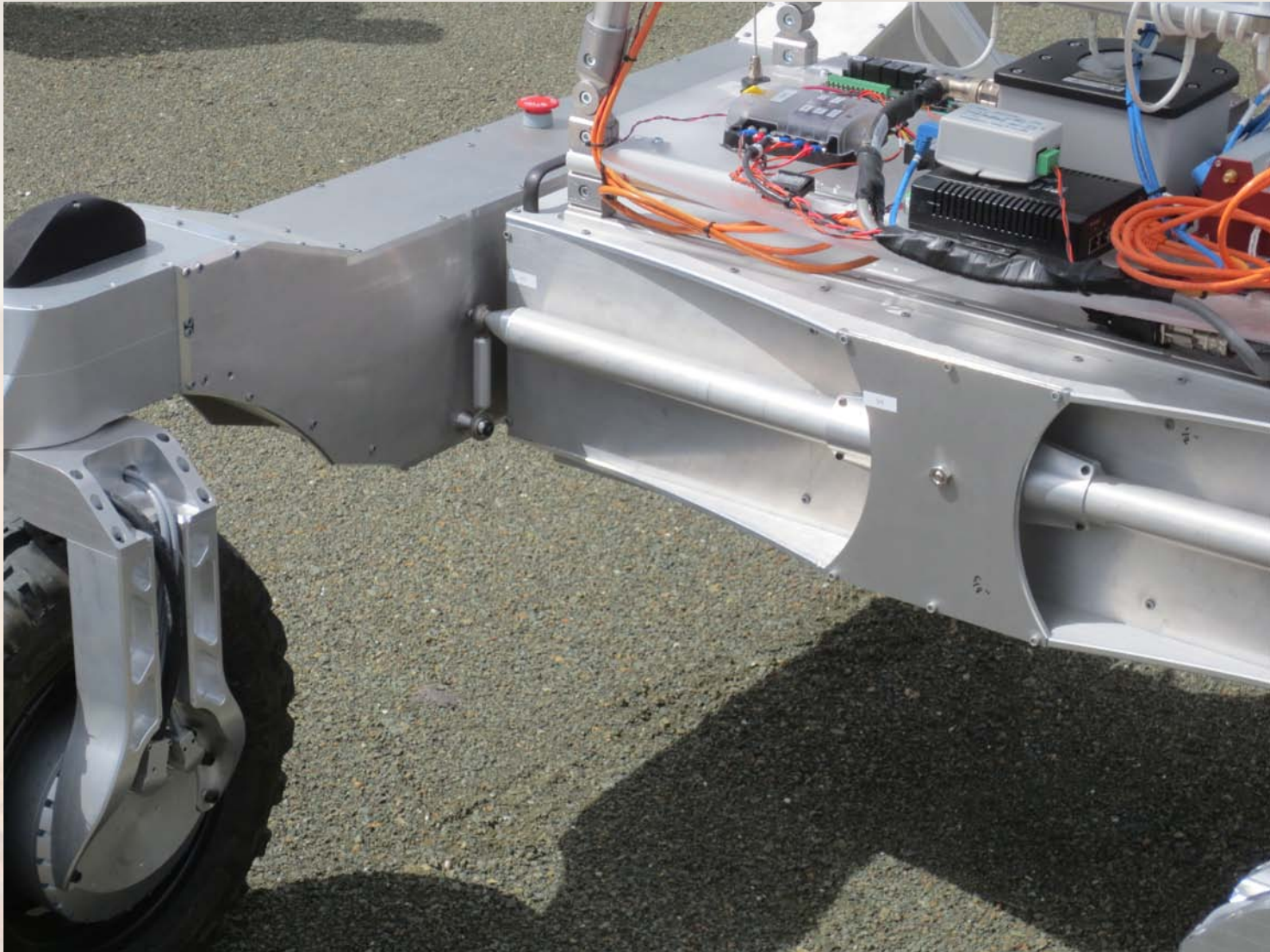



# K-Rex Steering Demonstration



# K-Rex Obstacle Handling Demo



# Lunar X-Prize (CMU)

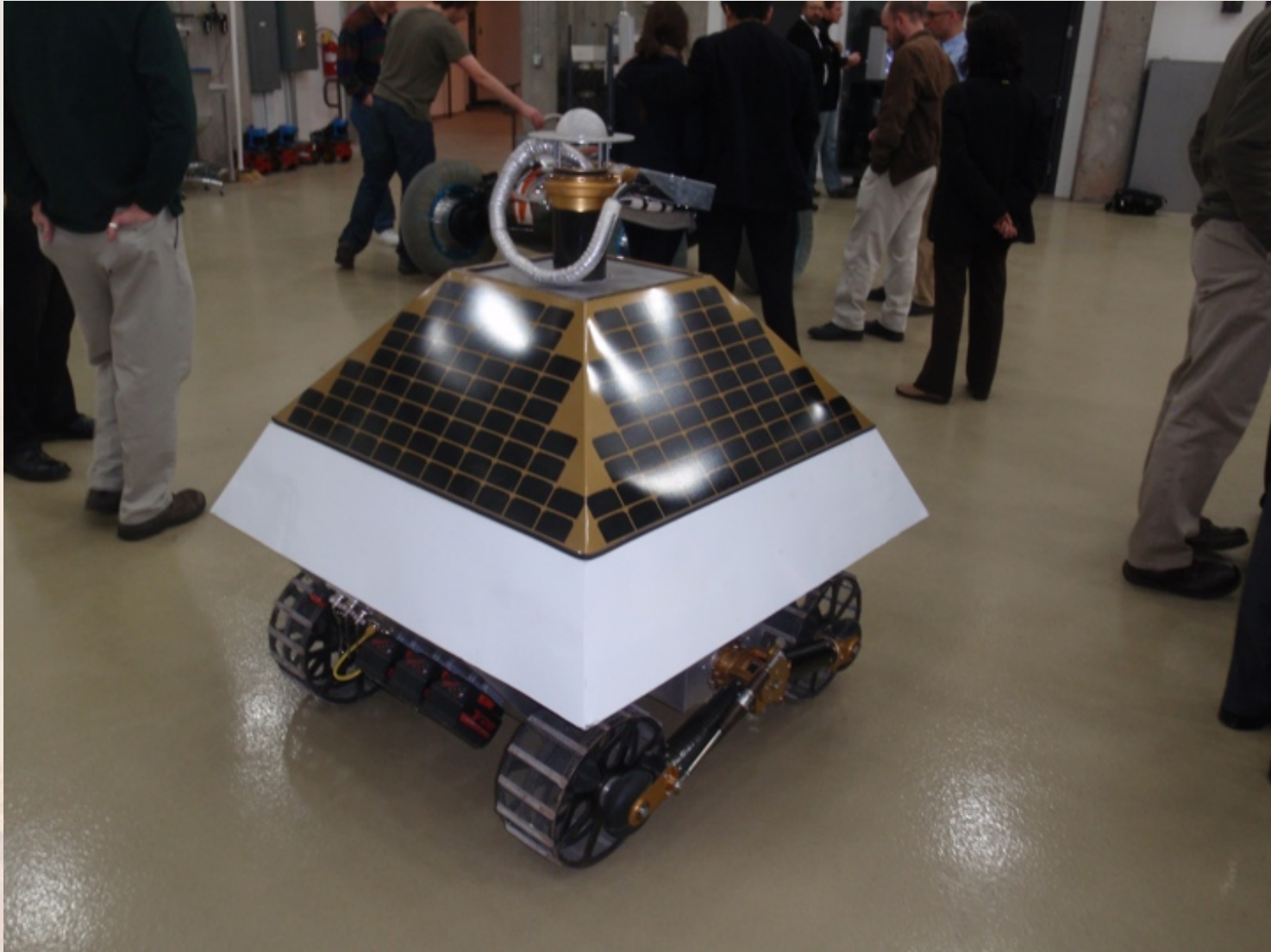

# Articulated Bogey Configuration



# Segmented Body - Marsokhod

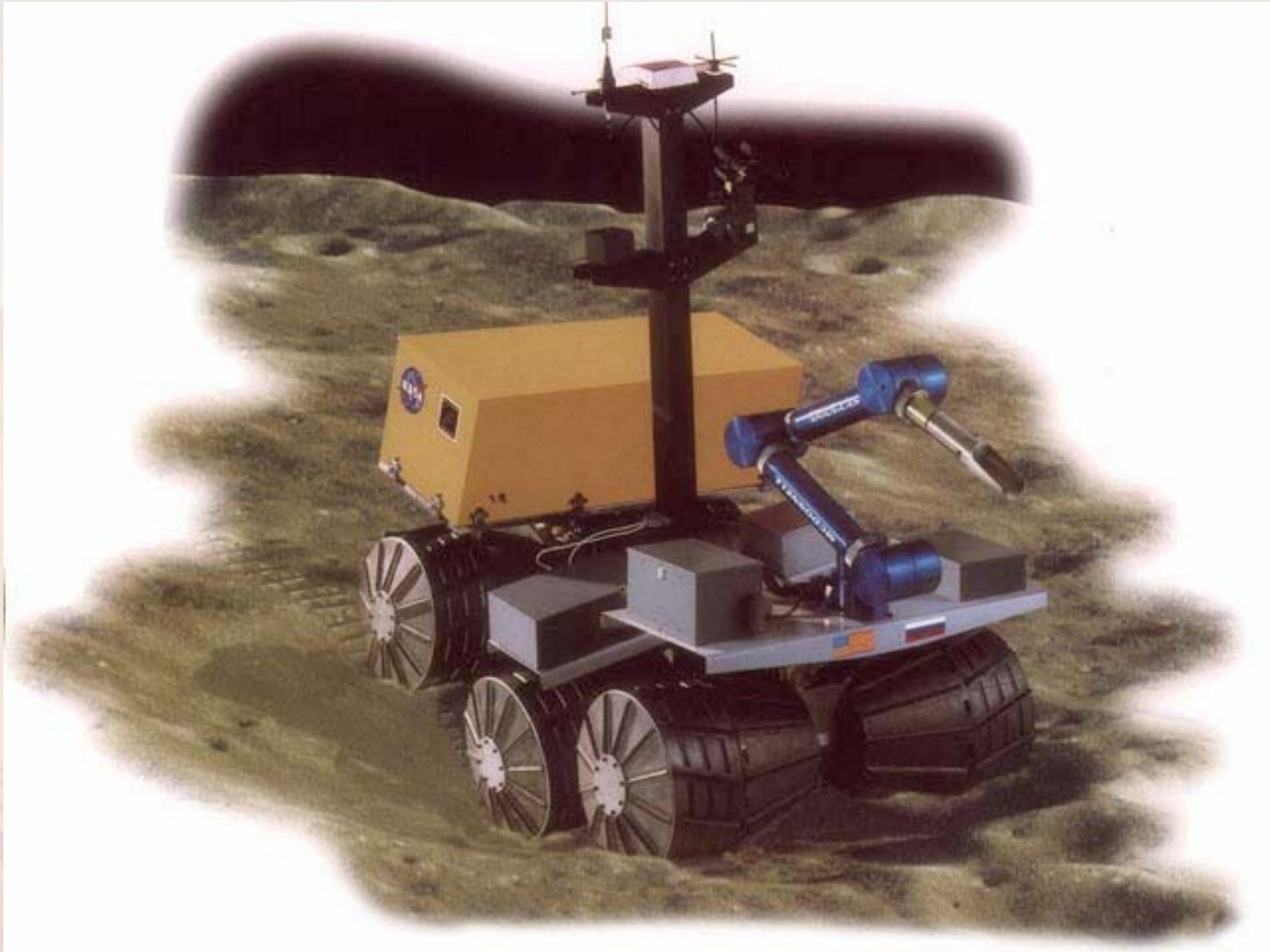

# Marsokhod Chassis

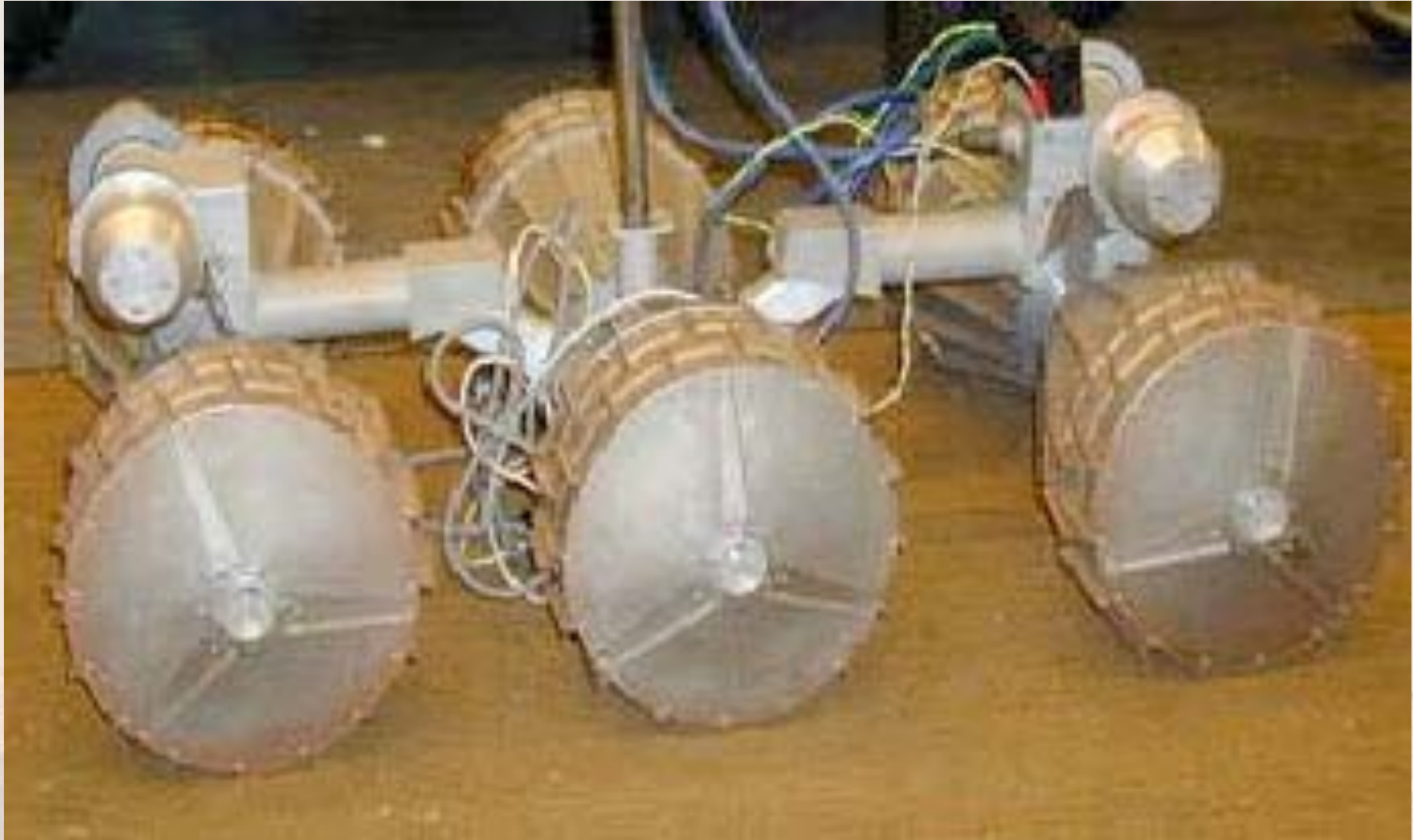

# Robby (JPL)



# Go-For (JPL)



UNIVERSITY OF  
MARYLAND



# SCARAB (CMU)



UNIVERSITY OF  
MARYLAND

# Scarab Wheel Articulation (CMU)

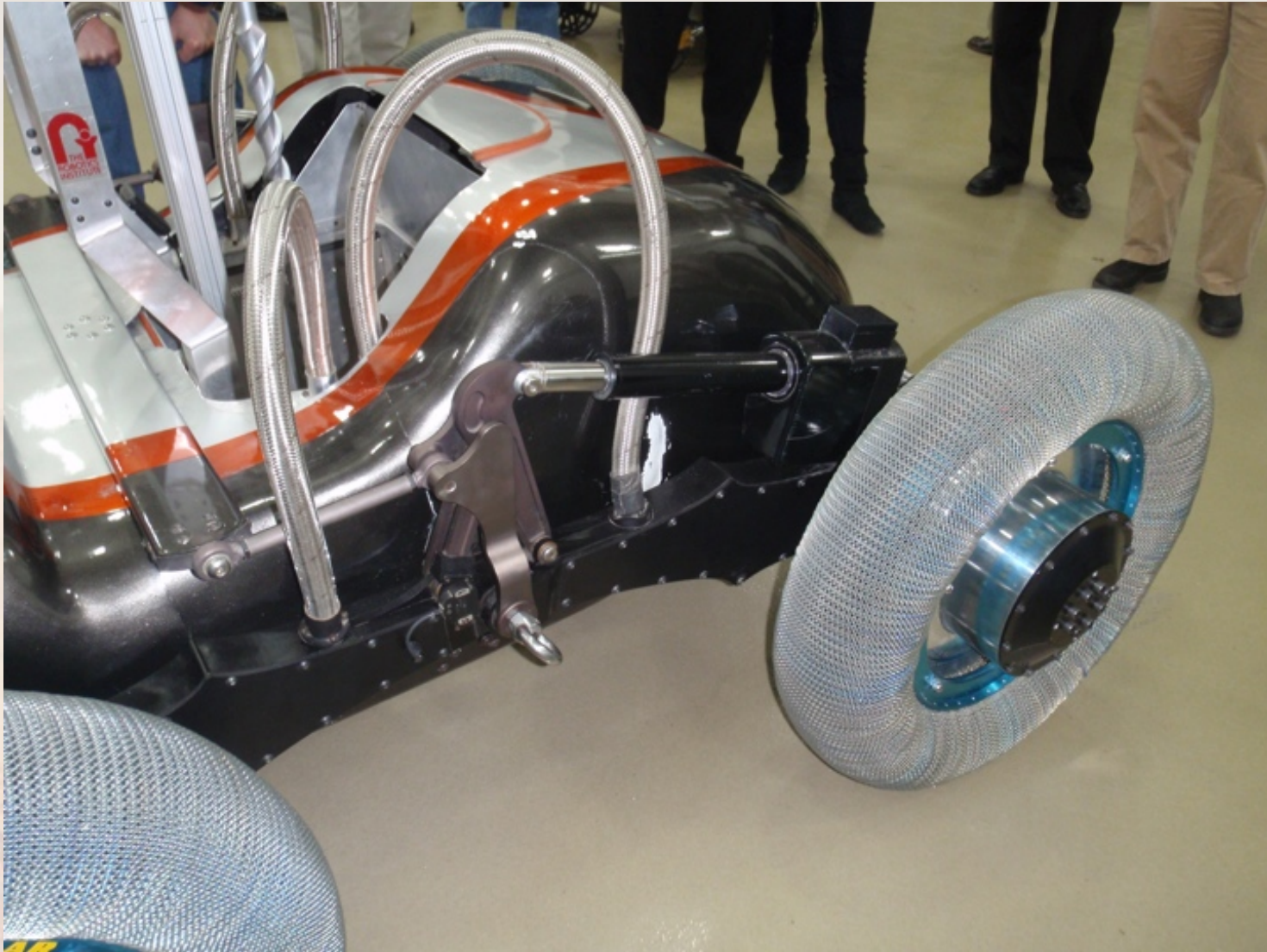

# SCARAB at Full Extension (CMU)



# Mars Rover (VNIITransmash -



# Apollo Lunar Roving Vehicle

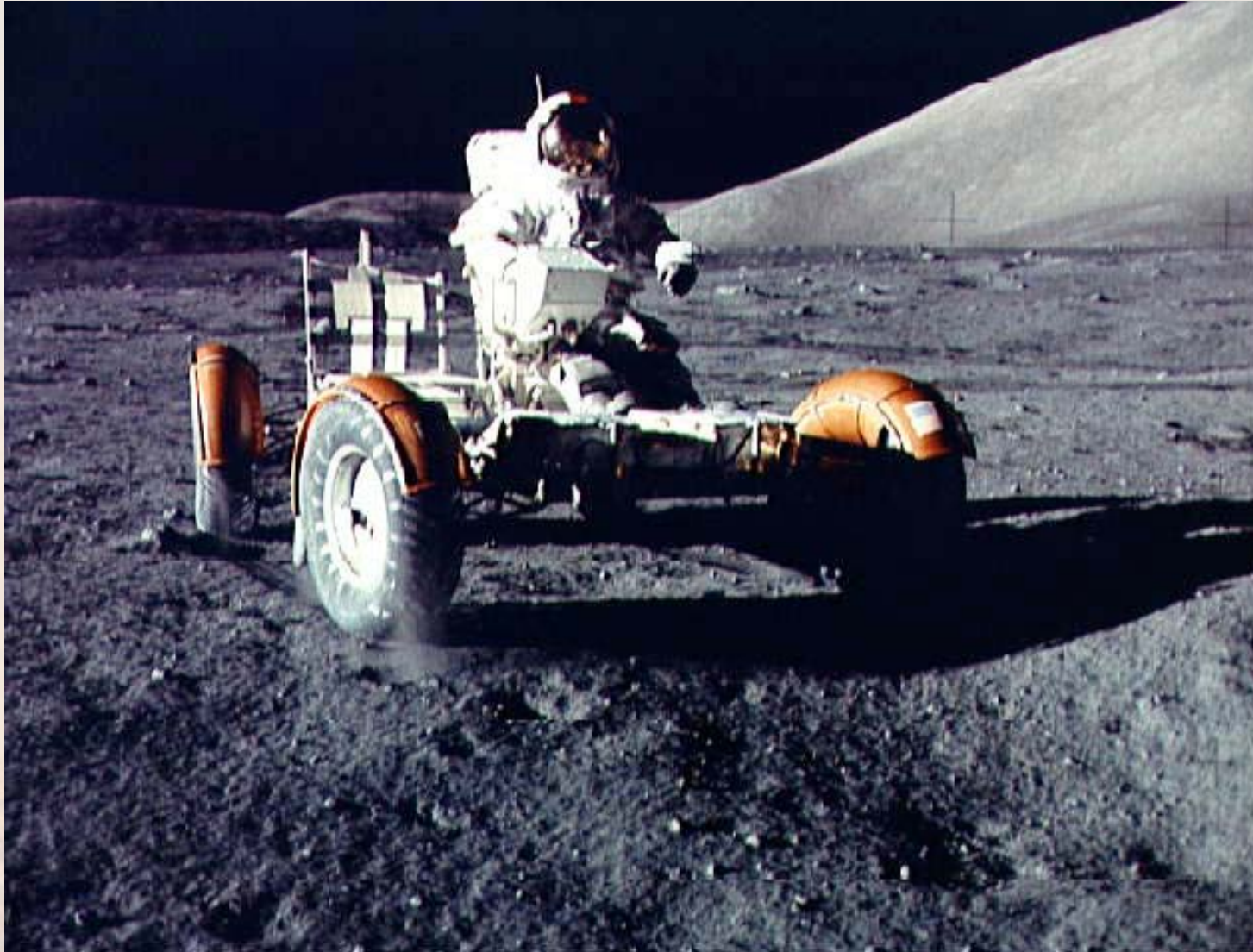

# SCOUT Rover (JSC)



UNIVERSITY OF  
MARYLAND

# Electric Tractor and Chariot (JSC)



# Active Suspension - Chariot



UNIVERSITY OF  
MARYLAND



# Chariot B Climbs a Boulder Field



# SEV Driving Onto $\sim 20^\circ$ Slope



# SEV on $\sim 20^\circ$ Slope



# SEV Dual Bogie Soil Contact



# ATHLETE (JPL)



# Centaur with Robonaut (JSC)



# Centaur Body Pose and Turning



# Palm Pilot Robot (CMU)(Holonomic)





# Tessellator (CMU) (Holonomic)

