

Rocket Propulsion

An Introduction to

Fifth Edition

Elements

the Engineering of Rockets

George P. Sutton

Associate Division Leader,

Lawrence Livermore National Laboratory

Formerly Hunsaker Professor of Aeronautical Engineering,

Massachusetts Institute of Technology and formerly

Assistant to the President, Rocketdyne,

a division of Rockwell International Corporation

A Wiley-Interscience Publication

John Wiley & Sons

New York • Chichester • Brisbane • Toronto • Singapore

Manned flight applications usually require higher reliability, redundancy, safety margins, reuseability, more alternate operating modes, easier accessibility for repair/replacement, and thus more extensive tests and demonstrations compared to unmanned applications.

3. Propellant Feed System

The selection of a particular feed system and its components is governed primarily by the application of the rocket, its size, propellant, thrust, flight program, duration, number or type of thrust chambers, past experience, and by general requirements of simplicity of design, ease of manufacture, reliability of operation, and minimum weight. A classification of several of the more important types of feed systems is shown in Figure 7-2 and some are discussed in more detail in Chapter 9.

Gas-Pressure Systems

One of the simplest and most common means of pressurizing the propellants is to force them out of their respective tanks by displacing them with high-pressure gas. This gas is fed into the propellant tanks at a controlled pressure, thereby giving a controlled propellant discharge.

For low thrust and/or short duration, such as for space vehicle attitude control, a feed system of this type is preferred. Although the propellant tanks in gas-pressure feed systems have to be heavy to withstand the high internal pressures, the overall system weight can be lower than that of a turbopump system for these applications. Because of their relative simplicity, the rocket engines with pressurized feed systems can be very reliable. Reference 7-3 is a design guide for pressurized gas systems.

A simple pressurized feed system is shown schematically in Figure 1-3. It consists of a high-pressure gas tank, a gas shutoff and starting valve, a pressure regulator, propellant tanks, propellant valves, and feed lines. Additional components, such as filling and draining provisions, check valves, filters, flexible elastic bladders for separating the liquid from the pressurizing gas, and pressure sensors or gauges, are also often incorporated. After all tanks are filled, the high-pressure air valve in Figure 1-3 is remotely actuated and admits air through the pressure regulator at a constant pressure to the propellant tanks. The check valves prevent mixing of the oxidizer with the fuel when the unit is not in an upright position. The propellants are fed to the thrust chamber by opening valves. When the propellants are completely consumed, the pressurizing air also scavenges and cleans lines and valves of liquid propellant residue. The variations in this system, such as the combination of several valves into one or the elimination and addition of certain components,

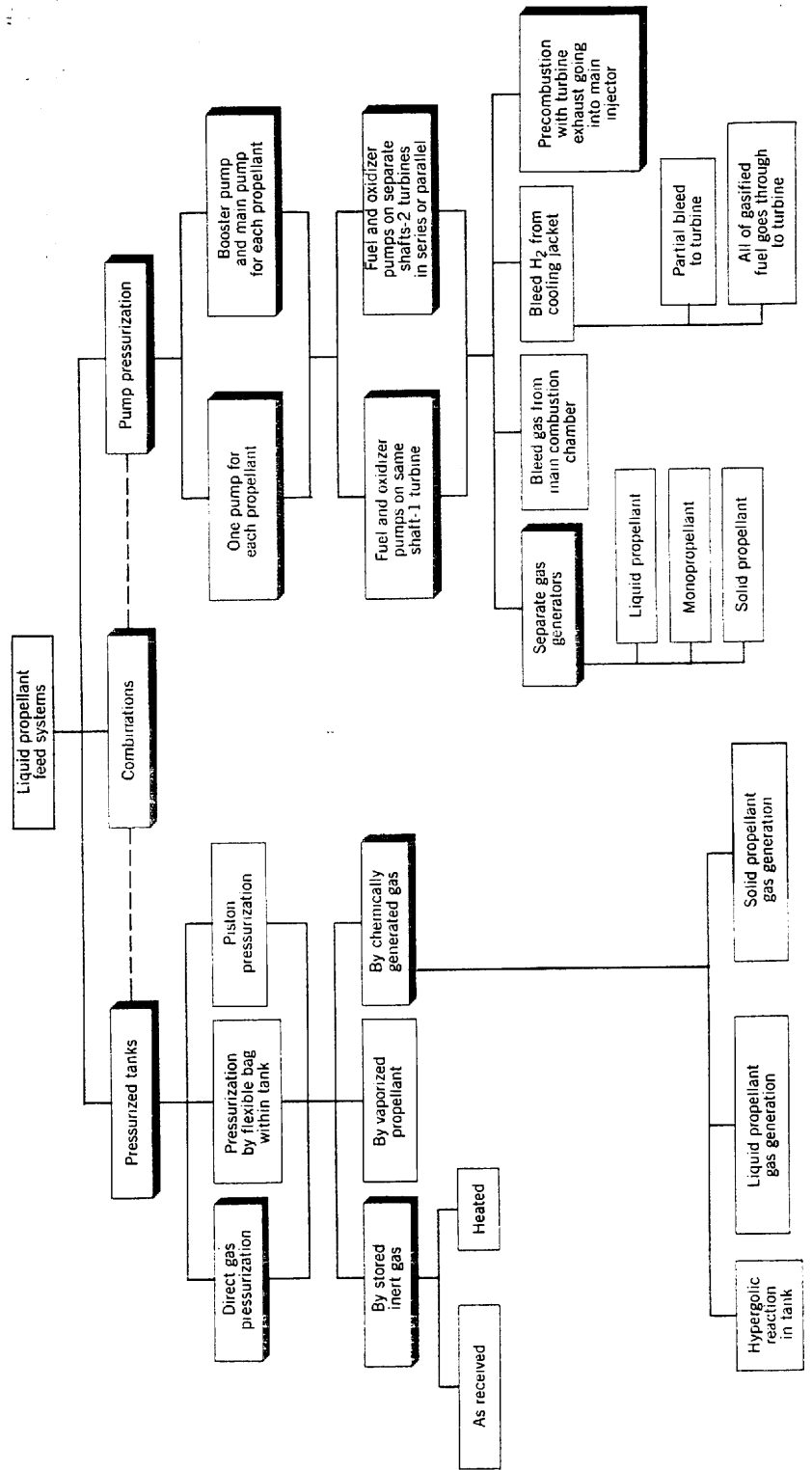

Fig. 7-2. Classification of liquid propellant rocket feed systems. The shaded boxes show the most common types.

depend to a large extent on the application. If a unit is to be used over and over, such as a space-maneuver rocket, it will include several additional features, such as, possibly, a thrust-regulating device and a tank level gauge; they will not be found in an expendable, single-shot unit, which may not even have a tank-drainage provision. Different bipropellant pressurization concepts are evaluated in Reference 7-4.

Turbopump System

The turbopump rocket feed system pressurizes the propellants by means of *pumps*, which in turn are driven by *turbines*. The turbines derive their power from the expansion of hot gases (see Figures 1-4, 7-3, 7-4, 9-15, and 9-16 and References 7-2 and 7-5). Turbopump rocket systems are usually used on high-thrust and long-duration rocket units; they are lighter than other types for these applications. Their engine weight is essentially independent of duration. More information on turbopumps and gas generators can be found in Chapter 9.

There are two classes of turbopump-fed rocket engine cycles, namely, *open cycles* and *closed cycles*. Several individual cycles have been developed within each of these two classes. *Open* denotes that the working fluid exhausting from the turbine is discharged overboard, after having been expanded in a nozzle of its own, or discharged into the engine nozzle at a point in the expanding section downstream of the main thrust chamber nozzle. In *closed cycles* or *topping cycles* all the working fluid from the turbine is injected into the engine combustion chamber to make the most efficient use of its remaining energy. In closed cycles the turbine exhaust gas is expanded through the full pressure ratio of the main thrust chamber, thus giving a little more performance than the open cycles, where these exhaust gases expand only through a relatively small pressure ratio. The overall engine performance difference is typically between 1 and 5% of I_s , and this is reflected in even larger differences in vehicle performance.

Figure 7-4 schematically shows the more prominent cycles available for liquid rockets. The one used most commonly in operational rockets today is the *gas generator cycle*. Here gases are present in a ratio different from the mixture ratio of the main thrust chamber, so as to generate gases at 900 to 1400°K suitable for use with uncooled turbine blades. Engines shown in Figures 1-4 and 7-1 use this cycle. The gas generator typically consumes between 1 and 5 percent of the total propellants. Usually the closed cycles are more complex. Some are best suited to cryogenic propellants. The schematic diagrams show each cycle with separate turbines for the fuel and oxidizer pumps in parallel; however, a series or single-turbine arrangement is also feasible and often reduces the hardware weight, volume, and cost. The "best" cycle varies with the characteristics of the flight mission, the suitability of existing engines, the type of propellants, and other factors.

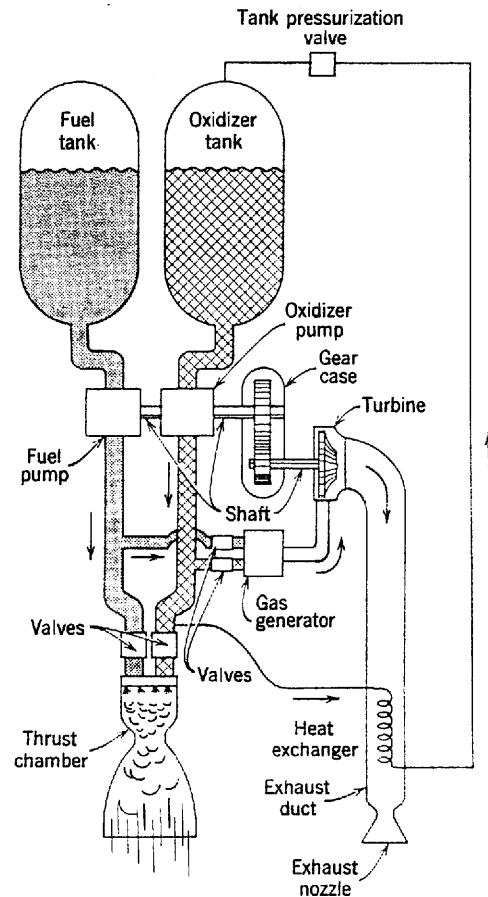
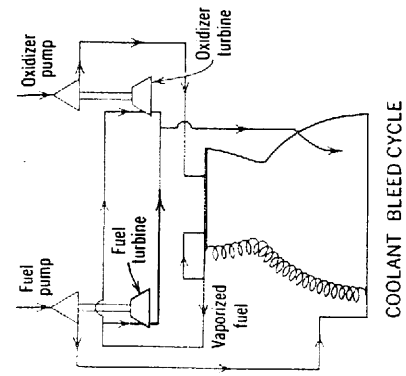

Fig. 7-3. Simplified schematic diagram of a liquid propellant rocket engine with turbopump feed system and a separate gas generator.

In the *gas generator cycle* the propellants, whether monopropellants or bipropellants, can come from the main propellant feed system or from separate propellant tanks. In engines such as the F-1 shown in Figure 1-4, the turbine exhaust is dumped into the thrust chamber nozzle at a point where the pressure is approximately the same as at the turbine exit.

The *combustion tap-off cycle* has the advantage that it eliminates the gas generator. The hot gases needed by the turbine are bled from the engine combustion chamber at a point near the injector face which supplies gases at the desired temperature, usually less than half of peak temperature in the chamber.

The *coolant tap-off* or *bleed cycle* is usually restricted to engines with hydrogen fuel. Vaporized hydrogen is bled from the thrust chamber jacket and supplied to the turbine. Like the combustion tap-off cycle, the main advantage



OPEN CYCLES

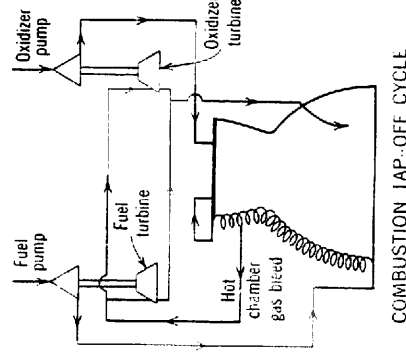

GAS GENERATOR CYCLE

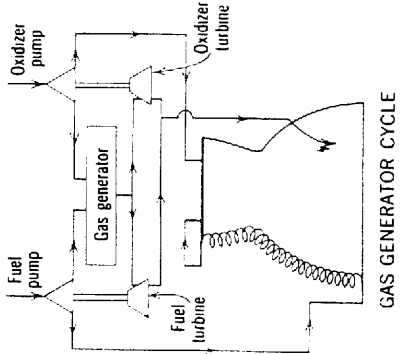

COMBUSTION TAP-OFF CYCLE

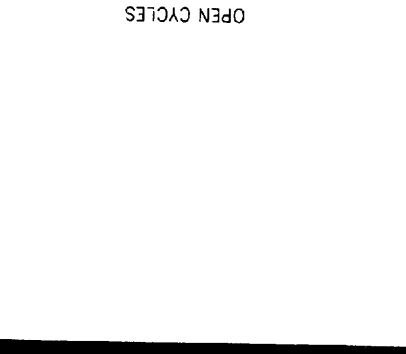

COOLANT BLEED CYCLE

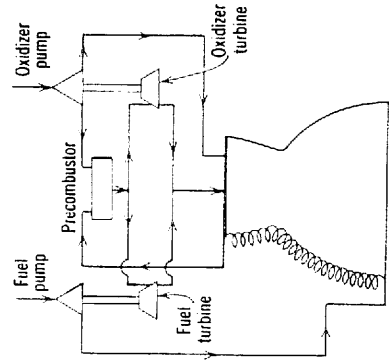

EXPANDER CYCLE

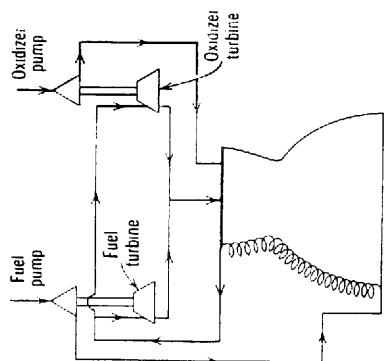

STAGED-COMBUSTION CYCLE

CLOSED CYCLES

STAGED-COMBUSTION CYCLE

Fig. 7-4. Turbopump feed system cycles for liquid propellant rocket engines.

is the absence of the gas generator. The energy level of the turbine working fluid is set by the permissible cooling jacket temperature and the coolant properties, which invariably restrict the turbine power to relatively low levels compared to the other open cycles.

In the *expander cycle* most of the engine coolant (usually hydrogen fuel) is fed to low-pressure-ratio turbines after having passed through the cooling jacket where it picked up energy. Part of the coolant, perhaps 5 to 15%, bypasses the turbine and rejoins the turbine exhaust flow before the entire coolant flow is injected into the engine combustion chamber where it mixes and burns with the oxidizer. See Reference 7-6. The primary advantages of the expander cycle are good specific impulse, engine simplicity, and relatively low weight. In the expander cycle all the propellants are fully burned in the engine combustion chamber and expanded efficiently in the engine exhaust nozzle. For high chamber pressure, the energy required for driving the turbine is larger than can practically be supplied by the vaporized fuel; this cycle is not practical above chamber pressures greater than 7.58 megapascal or 1100 psi. The fuel pump discharge pressure is much higher than in an open-cycle system.

In the *staged combustion cycle*, the coolant flow path through the cooling jacket is the same as that of the expander cycle. Here a high-pressure precombustor (gas generator) burns all the fuel with part of the oxidizer to provide high-energy gas to the turbines. The total turbine exhaust gas flow is injected into the main combustion chamber where it burns with the remaining oxidizer. Because of the precombustor, this cycle lends itself to high-chamber-pressure operation and allows a small thrust-chamber size. The extra pressure drop in the precombustor and turbines causes the pump discharge pressures of both the fuel and the oxidizer to be much higher than with open cycles, requiring heavier and more complex pumps, turbines, and piping. This cycle is capable of providing the highest specific impulse. A variation of this cycle is used in the Space Shuttle main engine, as shown in Figure 7-5. This engine actually uses two separate precombustion chambers, each mounted directly on a separate main turbopump. In addition, there are two more turbopumps for providing a boost pressure to the main pumps, but their turbines are not driven by combustion gases; instead, high-pressure liquid oxygen drives one booster pump and a bleed of evaporated hydrogen drives the other. The injector of this reusable liquid propellant high-pressure engine is shown in Figure 8-6 and performance data are given in Table 9-1.

From an inspection of the schematic flow diagram in Figure 7-3, the following basic feed-system relationships are readily deduced. The flow through either pump m_f or m_o must equal the respective propellant flow through the generator m_{gg} and the chamber m_c .

$$\dot{m}_o = (\dot{m}_o)_{gg} + (\dot{m}_o)_c \quad (7-7)$$

$$\dot{m}_f = (\dot{m}_f)_{gg} + (\dot{m}_f)_c$$

$$\dot{m}_c = (\dot{m}_o)_c + (\dot{m}_f)_c \quad (7-8)$$

$$\dot{m}_{gg} = (\dot{m}_o)_{gg} + (\dot{m}_f)_{gg} \quad (7-9)$$

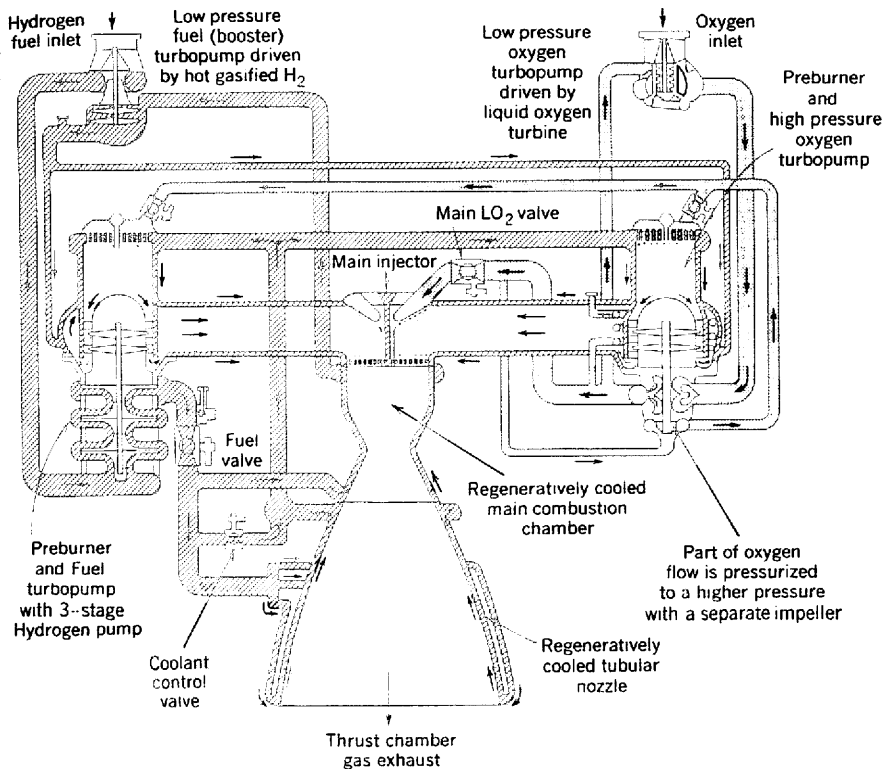

Fig. 7-5. Flow diagram for staged combustion cycle used in Space Shuttle main engine using liquid oxygen and liquid hydrogen propellants. (Courtesy Rocketdyne, division of Rockwell International Corp.)

In the turbopump the torques, powers, and shaft speeds must match. The balance of shaft speeds N can be simply written as

$$N_t = a_o N_o = a_f N_f \tag{7-10}$$

where a_o , and a_f are gear ratios. If no gears are used, $a_o = a_f = 1$. The power balance implies that the power of turbine P_T equals the power consumed by pumps and auxiliaries. The power is expressed as the product of torque L and shaft speed N .

$$P_T = L_T N_T = L_o N_o + L_f N_f + P_b \tag{7-11}$$

where P_b represents the bearing, seal, friction, and transmission power losses. If there are no gears in a particular turbopump then

$$N_T = N_o = N_f \tag{7-12}$$

$$L_T = L_o + L_f + L_b \tag{7-13}$$

The pressure balance equations for the fuel line at a point downstream of the fuel pump can be written as

$$\begin{aligned}(p_f)_d &= (p_f)_s + (\Delta p)_{\text{pump}} \\ &= (\Delta p)_{\text{main fuel system}} + p_1 \\ &= (\Delta p)_{\text{generator fuel system}} + p_{gg}\end{aligned}\quad (7-14)$$

Here the fuel discharge pressure $(p_f)_d$ equals the fuel pump suction pressure $(p_f)_s$ plus the pressure rise across the pump $(\Delta p)_{\text{pump}}$; this in turn equals the chamber pressures p_1 plus all the pressure drops in the main fuel system downstream of the pump, and this is further equal to the chamber pressure in the gas generator combustion chamber p_{gg} augmented by all the pressure losses in the fuel piping between the generator and the downstream side of the fuel pump. The pressure drop in the main fuel system usually includes the losses in the cooling jacket and the pressure decrease in the injector. Equations 7-7 through 7-14 are for a steady-state condition. The transients and the dynamic change conditions are rather complex but have been analyzed using iterative procedures and digital computers.

4. Propellant Tanks

The liquid rocket engine system usually has an oxidizer tank and a fuel tank; monopropellant rocket engine systems have, of course, only one propellant tank, and with certain types of feed systems there is also a high-pressure pneumatic gas tank. Tanks can be arranged in a variety of ways and the tank design can be used to exercise some control over the change in the location of the center of gravity. Typical arrangements are shown in Figure 7-6. Because the propellant tank has to fly, its weight is at a premium and the tank material is therefore highly stressed. Detailed stress considerations are omitted in this discussion, because stresses for irregular tank shapes are beyond the scope of this book, and because other loads besides internal pressure should be taken into consideration.

Cryogenic propellants cool the tank wall temperature far below the ambient air temperature. This causes condensation of moisture on the outside of the tank and usually also formation of ice during the period prior to launch. The ice is undesirable, because it increases the vehicle inert weight and can cause valves to malfunction. For an extended storage period, cryogenic tanks are usually thermally insulated; porous external insulation layers have to be sealed to prevent moisture from being condensed inside the insulation layer. With liquid hydrogen it is possible to liquify or solidify the ambient air on the outside of the fuel tank. Even with heavy insulation and low conductivity structural tank supports, it is not possible to prevent the continuous evaporation of the cryogenic fluid and therefore all cryogenic tanks usually include

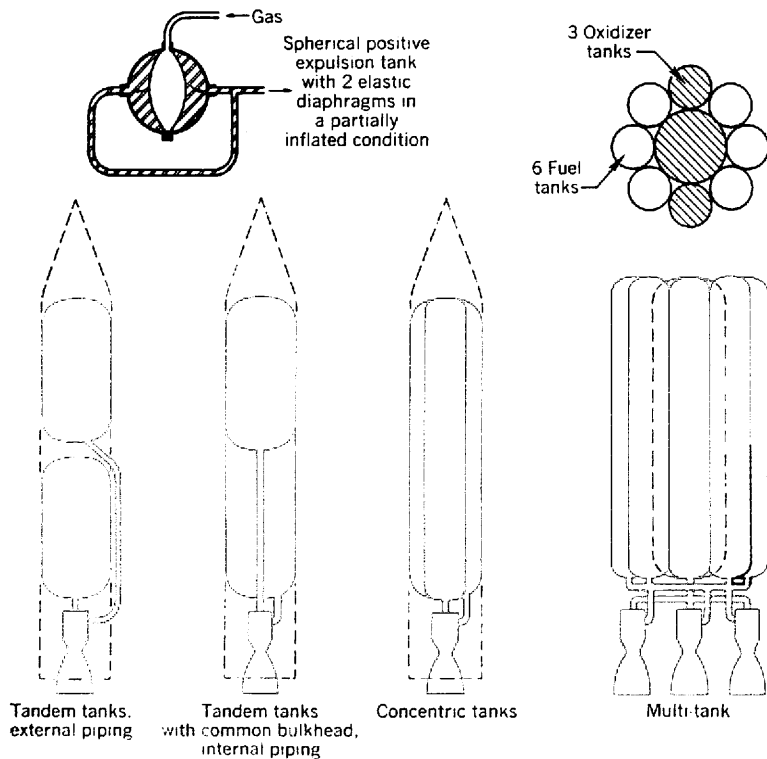

Fig. 7-6. Typical tank arrangements.

vents or other pressure relief provisions to prevent self-over-pressurization. For storage of cryogenic propellants in a space vacuum some form of a powered refrigeration system is needed to minimize evaporation losses.

The optimum shape for propellant tanks is spherical, for it gives a tank with the least weight. Unfortunately, spheres are not very desirable for vehicles flying in the atmosphere. Propellant tanks are often made integral with the vehicle fuselage or wing and can be irregular in shape.

There are essentially two types of propellant tanks: (1) high-pressure tanks which include (a) gas supply tanks (6.89 to 34.5 mega pascals or 1000 to 5000 lb/in^2), and (b) pressurized propellant tanks (2.07 to 4.83 mega pascals or 300 to 700 lb/in^2) and (2) low-pressure tanks, which are propellant tanks for pump feed systems (0.07 to 0.34 mega pascals or 10 to 50 lb/in^2).

In some pressurized propellant tank designs the pressure gas mixes violently with the propellant, forming gas bubbles within the liquid, thereby causing erratic rocket operation. A flexible bag separating the liquid and the gas solves this problem. The emptying of the propellant is sometimes difficult under flight conditions and zero acceleration. Antiaircraft missiles, antiballistic-missile missiles, or other vehicles that undergo heavy side accelerations need special

propellant-tank-emptying provisions to prevent the tank outlet from being bare of liquid during operational maneuvers, as shown in Table 9-4. The German "Wasserfall" antiaircraft missile used swiveled flexible filler necks at the tank outlets and the U.S. Lance missile uses pistons. Also, special provisions (such as baffles) have to be made to reduce the effect of the *sloshing of liquids in the tanks* and to minimize the *formation of a vortex* in a tank that is being emptied. Means for positive expulsion of the liquid need to be used if an engine is to be started in a zero gravity condition, such as in space. This can be a small positive acceleration (from a small separate rocket), a system of inflatable diaphragms in the tank (see top left of Figure 7-6), or a series of screens using surface tension to retain liquid.

The extra volume of gas above the propellant is referred to as the *ullage*. It is necessary space which allows for thermal expansion of the propellant liquids and for the accumulation of dissolved gases or of gaseous products of slow reactions within the propellant during storage.

5. Auxiliary Uses of Propellants

In a typical liquid rocket propulsion system, the propellant supply from the missile tanks is often used for purposes other than producing thrust. A typical schematic flow diagram illustrating the use of a cryogenic propellant for pressurizing its own vehicle tank is shown in Figure 7-3. As mentioned in Section 3 of this chapter, a small portion of the propellants is often burned in a separate gas generator chamber or bled from the thrust chamber and used to drive the turbopumps. In a few applications the gas is used to drive hydraulic pumps or electrical generators.

In some applications, a small amount of one or both of the propellants is utilized for the pressurization of the main propellant tanks. By bleeding cryogenic propellant off at the high-pressure pump discharge, vaporizing it in a heat exchanger, and piping it back to the tanks, the necessary pressurization can be achieved. This is done in the Atlas and the V-2 oxygen-tank pressurizing system and most hydrogen-oxygen engines.

6. Performance of Complete Rocket Engine Systems

The simplified relations that follow give the basic method for determining the overall specific impulse, the total propellant flow, and the overall mixture ratio as a function of the corresponding component performance terms for complete rocket engine systems. This applies to engine systems consisting of one or more thrust chambers, auxiliaries, turbines, and evaporative propellant pressurization systems. The subscripts *oa*, *o*, and *f* designate the overall engine

system, the oxidizer, and the fuel, respectively. Then

$$(I_s)_{oa} = \frac{\sum F}{\sum \dot{w}} = \frac{\sum F}{g_0 \sum \dot{m}} \quad (7-15)$$

$$\dot{w}_{oa} = \sum \dot{w} \quad \text{or} \quad \dot{m}_{oa} = \sum \dot{m} \quad (7-16)$$

$$r_{oa} = \frac{\sum \dot{w}_o}{\sum \dot{w}_f} = \frac{\sum \dot{m}_o}{\sum \dot{m}_f} \quad (7-17)$$

These same equations should be used for determining the overall performance when more than one rocket engine is contained in a vehicle propulsion system.

EXAMPLE 7-2. For an engine system similar to the one shown in Figure 7-3 determine a set of equations that will express (1) the overall engine performance and (2) the overall mixture ratio of the propellant flows from the tanks. Let the following subscripts be used: *c* thrust chamber, *gg* gas generator, and *tp* tank pressurization.

Solution. Only the oxidizer tank is pressurized by vaporized propellant. Although this pressurizing propellant must be considered in determining the overall mixture ratio, it should not be considered in determining the overall specific impulse since it stays with the vehicle and is not exhausted overboard.

$$(I_s)_{oa} = \frac{F_c + F_{gg}}{\dot{m}_c + \dot{m}_{gg}} \quad (7-18)$$

$$r_{oa} = \frac{(\dot{m}_o)_c + (\dot{m}_o)_{gg} + (\dot{m}_o)_{gg}}{(\dot{m}_f)_c + (\dot{m}_f)_{gg}} \quad (7-19)$$

7. Thrust Vector Control

In addition to merely providing a propulsive force to a vehicle, the rocket engine can also provide attitude control, that is, control of the vehicle's pitch, yaw, and roll moments. Although this discussion is located here in the chapter on liquid propellant rocket engines, in principle these vector controls apply equally well to solid propellant rocket motors (see Chapter 12, Section 5).

Pitch moments are those that raise or lower the nose of a vehicle; *yaw moments* turn the nose sideways; and *roll moments* are applied about the main axis of the flying vehicle. Usually the thrust vector of the main rocket nozzle is in the direction of the vehicle axis and goes through the vehicle's center of gravity. Thus it is usually possible to obtain pitch and yaw control moments by the simple deflection of the main rocket thrust vector; however, roll control usually requires the use of two or more rotary vanes or two or more separately hinged thrust chambers.

In liquid propellant rocket engines several different methods of vector control can be employed as illustrated by representative types in Figure 7-7. Other schemes are shown in Figures 12-9 to 12-14.

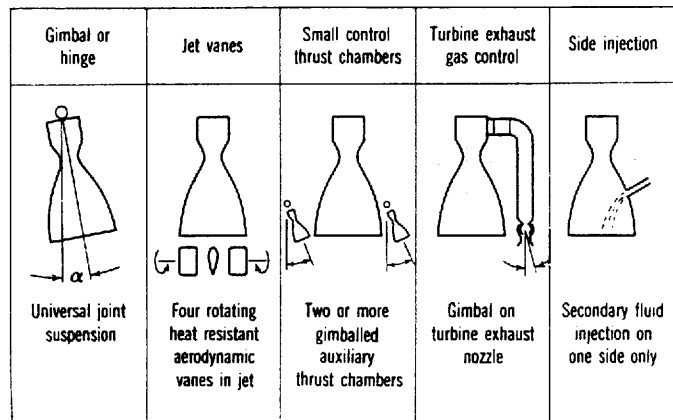

Fig. 7-7. Thrust vector control methods for liquid propellant rocket engines.

In the *hinge* or *gimbal* scheme (a hinge permits rotation about one axis only, while a gimbal is essentially a universal joint), the whole engine is pivoted on a bearing and thus the thrust vector is rotated. For small angles this scheme has negligible losses in specific impulse and is used in many vehicles. It requires a flexible set of propellant piping (bellows) to allow the propellant to flow from the tanks of the vehicle to the moveable engine. With two or more hinged or gimballed engines one can obtain roll control. The Space Shuttle (Figure 1-12) has two gimballed orbit maneuver nozzles and three gimballed main nozzles. Figures 1-4 and 7-1 show gimballed engines.

Jet vanes are pairs of heat-resistant, aerodynamic surfaces submerged in the exhaust jet of a fixed rocket nozzle. They were used about 40 years ago, but the extra drag (2 to 3% less I_s) and the erosion of the vane material have made this method obsolete.

Small auxiliary thrust chambers are used when it is desired to control the vehicle after the main rocket engine is shut off. In the Thor and Atlas missiles small vernier rockets are used in this way, but they also provide roll control while the principal rocket operates.

The deflection of the *turbine exhaust gas* is a desirable scheme for roll control. This can be used together with a gimballed thrust chamber or (by splitting the turbine exhaust into two flow streams) as two separately hinged control nozzles. The moments applied to the vehicle by this method are small. The turbine exhaust must be vented overboard in any case, and usually the addition of a hinged nozzle at the exhaust duct exit is not an undue complication.

The *injection of secondary fluid* through the wall of the nozzle into the main gas stream has the effect of forming oblique shocks in the nozzle diverging section, thus causing a deflection of a part of the main gas flow. The secondary fluid can be stored liquid or gas from a separate hot gas generator (the gas

would then still be sufficiently cool to be piped), a direct bleed from the chamber, or the injection of a monopropellant. When the deflections are small, this is a low-loss scheme, but for large moments (large side forces), the amount of secondary fluid becomes excessive. This scheme has found application in solid propellant rockets as discussed in Chapter 12.

The selection of the vector control scheme depends on the characteristics of the engine and its flight application and considers such factors as duration, effective loss in engine performance, maximum vector deflection angles, maximum angular acceleration, environment, number of engines, available actuating power, linearity between actuating force and vehicle control movement, and weight and space limitations.

8. Auxiliary Rockets

Two or more auxiliary thrust chambers together with a separate pressurized feed system are used in spacecraft or missiles for the accurate *control of trajectories* or *orbit adjustment* and also for *attitude control* of the vehicle. As described in Section 6 of Chapter 5, small thrust rockets are a part of an attitude control system, which allows several important vehicle rotation maneuvers. Nomenclature and classification of attitude control rockets, also called reaction control systems, for spacecraft and missiles varies extensively. Broadly, the application of torque to spacecraft can be divided into two classes, *mass expulsion* types (rockets) and *non-mass expulsion* types. Non-mass expulsion types include momentum storage, gravity gradient, solar radiation, and magnetic systems. Some space satellites are equipped with both the mass and non-mass expulsion types. *Reaction wheels* or *fly wheels*, a momentum storage device, are particularly well suited to obtaining vehicle angular position control with high accuracies of less than 0.01° deviation and low vehicle angular rates of less than 10^{-5} degrees/sec with relatively little expenditure of energy. The vehicle angular momentum is changed by accelerating the wheel. Of course, when the wheel speed reaches the maximum permissible, no further electrical motor torquing is possible; the wheel must be decelerated to have its momentum removed, a function usually accomplished through the simultaneous use of small attitude control rockets, which apply a torque to the vehicle in the opposite direction.

Auxiliary rockets fall into three categories: cold gas jets (also called inert gas jets), warm or heated gas jets, and chemical combustion rockets, such as bipropellant liquid propellant rockets. The specific impulse is typically 65 to 75 sec for cold-gas systems and 105 to 230 sec for warm-gas systems. Warm gas systems can use inert gas with a heater in the storage tank or a monopropellant which is thermally decomposed. Bipropellant attitude control thrust chambers have varied from 5 to 4000 N thrust; the higher thrusts apply to large spacecraft (see Reference 7-7). All use basically pressurized feed systems with

**Table 7-1. Properties of Candidate Gaseous Propellants
Used in Attitude Control**

Propellant	Molecular Mass	Density ^a (lb/ft ³)	Theoretical Specific Impulse (sec)
Hydrogen	2.0	1.21	296
Helium	4.0	2.37	179
Methane	16.0	12.10	114
Nitrogen	28.0	17.37	80
Air	28.9	19.3	74
Argon	39.9	27.60	57
Krypton	83.8	67.20	39
Freon 14	88.0	60.01	55
Carbon dioxide	44.0	Liquid	67

^aAt 3500 psia and 0°C.

multiple thrust chambers equipped with fast-acting, positive-closing, precision valves. Many systems use small, uncooled, metal-constructed supersonic exhaust nozzles strategically located on the periphery of the spacecraft. Gas jets are used typically for low thrust (up to 10 N) and low total impulse (up to 4000 N-sec).

Table 7-1 lists some cold gaseous propellants. The selection of a gaseous propellant must consider many factors, including the weight of the storage tank, gas density, and molecular mass. Nitrogen, argon, krypton, and Freon 14 have been employed in operational spacecraft, but nitrogen has been the most common cold-gas propellant. With hydrogen and helium the system mass is substantially higher because the low gas density offsets their favorable specific impulse values. Some spacecraft have operated for three years with cold-gas attitude control systems.

In future long-duration manned space missions, life support systems can be expected to supply by-product gases, mainly hydrogen, methane, and carbon dioxide; all are candidate gaseous propellants. Auxiliary rocket systems using propellants heated by energy from radioactive isotope materials are a likely possibility in the future; the propellant heating system can be combined with a radioisotope electrical generating unit for the spacecraft.

Trajectory correction and attitude control rockets also find application in the post-boost propulsion stage of large ballistic missiles that carry multiple payloads and in controlling the flight path of anti-ballistic-missile missiles (see Reference 7-8). Characteristically these applications requires small control rockets capable of providing high performance (usually storable liquid bipropellants), the application of multiple small-impulse bits (rapid thrust rise and a sharp cutoff), with high reproducibility of the thrust pulses. Most have cham-

ber pressures below 200 psi (1.4 megapascal). Also long-term (10 to 15 yr) storability is required.

Small liquid mono propellant and liquid bipropellant rocket units are common in auxiliary rocket systems for thrust levels typically above 2 N and total impulse values above 3000 N-sec. Hydrazine is the most common monopropellant used in auxiliary control rockets; nitrogen tetroxide and monomethyl-hydrazine is a common bipropellant combination. The next chapter contains data on these propellants, and Chapter 9 shows diagrams of small auxiliary thrust chambers. Cryogenic propellants which are already on board for primary propulsion are future candidates, especially for accomplishing propulsion-limited space missions, such as manned interplanetary travel. Water, decomposed in an electrolysis cell into gaseous hydrogen and oxygen, is a candidate propellant for vehicle control rockets (see Reference 7-8).

PROBLEMS

1. Enumerate and explain the merits and disadvantages of pressurized and turbopump feed systems.

2. In a turbopump system it is necessary to do more work in the pumps if the thrust chamber operating pressure is raised. This of course requires an increase in turbine gas flow, which, when exhausted, adds little to the engine specific impulse. If the chamber pressure is raised too much, the decrease in performance due to an excessive portion of the total propellant flow being sent through the turbine will outweigh the gain in specific impulse that can be attained by increased chamber pressure and also by increased thrust chamber nozzle exit area. Outline in detail a method for determining the optimum chamber pressure where the sea-level performance will be maximum for a rocket engine that operates in principle as the one shown in Figure 7-3.

3. The engine performance data for a turbopump rocket system are as follows:

Engine system specific impulse	272 sec
Engine system mixture ratio	2.52
Engine system thrust	40,000 N
Oxidizer vapor flow to pressurize oxidizer tank	0.003% of total oxidizer flow
Propellant flow through turbine	2.1% of total propellant flow
Gas generator mixture ratio	0.23
Gas generator specific impulse	85 sec

Determine performance of the thrust chamber (I_p , r , F).

4. For a pulsing rocket engine assume a simplified parabolic pressure rise of 0.005 sec, a steady-state short period of full chamber pressure, and a parabolic decay of 0.007 sec as shown in the sketch. Plot curves of the following ratios as a function of operating time from $t = 0.013$ to $t = 0.200$ sec:

- average pressure to ideal steady-state pressure (with 0 rise or decay time)
- average I_p to ideal steady-state I_p
- average F to ideal steady-state F

5. For a total impulse of 100 lb sec compare the volume and system weights of a pulsed propulsion system using different gaseous propellants each with a single spheri-

with a hot flame within the combustion chamber. Almost all solid propellant rockets and many liquid rocket chambers are ignited to this fashion. The igniter container may be designed to fit directly onto the injector or the chamber (see Figure 9-2), or may be held in the chamber from outside through the nozzle. This ignition method can only be used once; thereafter the charge has to be replaced.

In *precombustion chamber ignition* a small chamber is built next to the main combustion chamber and connected through an orifice, similar to precombustion chambers used in some internal combustion engines. A small amount of fuel and oxidizer is injected into the precombustion chamber and ignited. The burning mixture enters the main combustion chamber in a torch-like fashion and ignites the larger main propellant flow which is injected into the main chamber. This ignition procedure permits repeated starting of variable thrust engines and has proved successful with liquid oxygen-gasoline and oxygen-alcohol thrust chambers.

Auxiliary fluid ignition is a method whereby some liquid or gas, in addition to the regular fuel and oxidizer, is injected into the combustion chamber for very short periods during the starting operation. This fluid is hypergolic, which means it produces spontaneous combustion with either the fuel or the oxidizer. The combustion of nitric acid and some organic fuels can, for instance, be initiated by the introduction of a small quantity of aniline at the beginning of the rocket operation. Liquids that ignite with air (zincdiethyl or aluminum triethyl), when preloaded in the fuel piping, can accomplish a hypergolic ignition.

3. Sample Thrust Chamber Design Calculation

No general rule can be given for designing thrust chambers, since each particular design depends on the application, the selected propellant combination, the available data, and the experience of the designer. Tables 9-1 to 9-3 give typical design data. The following example illustrates the general application of several design considerations and the use of some of the equations developed in this and the previous chapters.

EXAMPLE 9-1. A thrust chamber is to be designed with the following specifications:

Propellants	Nitric acid and aniline (hypergolic)
Mixture ratio	2.75
Chamber pressure	300 psia
Atmospheric pressure	14.7 psia
Thrust	1000 lbf

The thrust chamber is to be designed for a cylindrical combustion chamber, a helically wound cooling coil with one of the propellants as coolant, and a multiple-hole injector with an injection pressure drop of 80 psi. The preceding specifications can be considered the requirements to which the unit has to conform. The selection of the

propellants, mixture ratio, chamber pressure, and chamber configuration are usually based on sound theoretical and experimental reasons which depend on the application, the availability of propellants and materials, and experience. Assume that the above are fixed and given. Several other basic quantities, such as the specific impulse, the chamber temperature, the mean molecular weight of exhaust gases, and the specific heat ratio, may now be determined. These quantities can be obtained from a thermochemical analysis of the acid-aniline propellant system for the mixture ratio and chamber pressure given. The method of this analysis is given in Chapter 6. The results of such a calculation are:

Chamber temperature	4930°F = 5390°R
Mean molecular weight of exhaust gases	25 lb/mole
Ideal specific impulse	218 sec
Specific heat ratio	1.22

1. Nozzle Configuration. The required nozzle cross sections and nozzle shape are now calculated. The nozzle coefficient C_F is determined from Equation 3-30. Because the atmospheric pressure is equal to the nozzle exit pressure ($p_2 = p_3$), the last term of this equation is equal to zero. Substituting $p_2 = 14.7$ psia, $p_1 = 300$ psia, and $k = 1.22$, gives $C_F = 1.41$. This value of C_F can also be determined from Figure 3-7. The thrust correction factor is assumed to be 0.96. Equation 3-35 is to be solved for the nozzle throat area.

$$A_t = F/(\zeta_F C_F p_1) = 1000/(0.96 \times 1.41 \times 300) = 2.47 \text{ in.}^2$$

The nozzle throat diameter is therefore $D_t = \sqrt{4A_t/\pi} = 1.77$ in. The ideal exhaust velocity can be found from the ideal specific impulse.

$$v_2 = I_v g = 218 \times 32.2 = 7020 \text{ ft/sec}$$

The actual effective exhaust velocity can be estimated by correcting the theoretical exhaust velocity by a velocity correction factor ($\zeta_v = 0.94$).

$$c = v_2 \zeta_v = 7020 \times 0.94 = 6600 \text{ ft/sec}$$

The nozzle exit area can be found from the continuity Equation 3-2 and from equations 2-5, 2-15, 3-3, and 3-6.

$$\begin{aligned} A_2 &= \frac{\dot{w} V_2}{v_2} = \frac{F g_0 V_1}{(v_2)^2} \left(\frac{p_1}{p_2} \right)^{1/k} = \frac{F g_0 T_1 R'}{(v_2)^2 p_1 \mathfrak{R}} \left(\frac{p_1}{p_2} \right)^{1/k} \\ &= \frac{1000 \times 32.2 \times 5390 \times 1544}{(6600)^2 \times 300 \times 25} (20.4)^{0.82} = 9.66 \text{ in.}^2 \end{aligned}$$

The nozzle area expansion ratio is $\epsilon = A_2/A_t = 9.66/2.47 = 3.9$. The nozzle exit diameter is $D_2 = \sqrt{4A_2/\pi} = 3.51$ in. The value of the nozzle area expansion ratio could also have been obtained from Equation 3-25 or from Figure 3-5. To summarize, the nozzle is determined as follows:

Throat area	2.47 in. ²
Exit area	9.66 in. ²
Throat diameter	1.77 in.
Exit diameter	3.51 in.
Nozzle diffuser half angle	15 deg
Exhaust velocity	6600 ft/sec

2. Chamber Configuration. A cylindrical shape has been chosen for this chamber. Gas velocities and Mach numbers in the chamber are very low compared to nozzle velocities. Although their values are not readily calculated or measured, a reasonable chamber velocity is believed to be between 200 and 500 ft/sec. By assuming a value of 425 ft/sec, an estimate of the chamber cross section can be made.

$$A_1 = \frac{\dot{w}V_1}{v_1} = \frac{Fg_0 R'T_1}{v_2 \mathcal{M} p_1 v_1} = \frac{1000 \times 32.2 \times 1544 \times 5390}{6600 \times 25 \times 300 \times 425} = 12.7 \text{ in.}^2$$

$$\text{Chamber diameter } D_c = \sqrt{4A_1/\pi} = 4.0 \text{ in.}$$

A similar result could also have been obtained by assuming a low chamber Mach number and using Equation 3-13. A chamber volume-to-throat-area ratio of approximately 40 appears desirable, $L^* = 40$. From Equation 9-1: $V_c = L^* A_t = 40 \times 2.47 = 99 \text{ in.}^3$. Because the exact chamber dimensions are not so critical as the nozzle dimensions, variations in chamber configuration do not appreciably affect the performance. The exact chamber dimensions may therefore be chosen as follows:

Chamber diameter	4.0 in.
Converging angle	30 deg
Chamber volume	99 in. ³
Length of cylindrical chamber portion	6.9 in.

A scaled sketch of the inside contour of the thrust chamber can now be drawn similar to the profile shown in Figure 4-2.

3. Injector Design. A multiple-hole impinging jet injector is arbitrarily chosen for this rocket because such injectors have previously given good performance with these propellants. Assume that there will be eight pairs of injection streams, each consisting of an oxidizer and a fuel jet, and that the resultant momentum of each jet pair is in an axial direction.

The propellant weight flow \dot{w} can be found from Equation 2-14

$$\dot{w} = Fg_0/c = 1000 \times 32.2/6600 = 4.88 \text{ lb/sec}$$

The oxidizer and fuel flow, according to Equations 7-3 and 7-4, are, respectively,

$$\dot{w}_o = \dot{w}r/(r+1) = 4.88 \times 2.75/(2.75+1) = 3.58 \text{ lb/sec}$$

$$\dot{w}_f = \dot{w}/(r+1) = 4.88/(2.75+1) = 1.30 \text{ lb/sec}$$

The following propellant quantities and properties are of concern:

Propellant	Aniline	Nitric Acid
Temperature of injected propellant	200°F	60°F
Specific gravity at injection temperature	0.97	1.5
Density at injection temperature	60.5 lb/ft ³	94 lb/ft ³
Heat of vaporization at standard conditions (Btu/lb)	187	207
Boiling point at 1 atm	364°F	191°F
Boiling point at 300 psia	650°F	—

The propellant injection volume flows are

$$Q_o = \dot{w}_o/\rho_o = 3.58 \times 1728/94 = 65.9 \text{ in.}^3/\text{sec}$$

$$Q_f = \dot{w}_f/\rho_f = 1.30 \times 1728/60.5 = 37.1 \text{ in.}^3/\text{sec}$$

From Equation 9-5 it is possible to calculate the injector hole areas. It is assumed that the injection pressure drops in the fuel and oxidizer lines are equal to 80 psi and that both orifice discharge coefficients are equal to 0.75. The conversion of pound-force and pound-mass in the terms \dot{w} and Δp requires a factor of g_0 .

$$\sum A_o = \frac{\dot{w}_o}{C_d \sqrt{2 g_0 \Delta p \rho_o}} = \frac{3.58 \times 144}{0.75 \sqrt{2} \times 32.2 \times 80 \times 144 \times 94} = 0.0822 \text{ in.}^2$$

$$\sum A_f = \frac{\dot{w}_f}{C_d \sqrt{2 g_0 \Delta p \rho_f}} = \frac{1.30 \times 144}{0.75 \sqrt{2} \times 32.2 \times 80 \times 144 \times 60.5} = 0.0372 \text{ in.}^2$$

Because there will be eight pairs of injection streams, the individual hole areas and diameters will be $A_o = 0.0822/8 = 0.0103 \text{ in.}^2$ and $A_f = 0.0372/8 = 0.00465 \text{ in.}^2$. The diameters then are $D_f = 0.077 \text{ in.}$ —use Drill No. 48 (0.076 in.) with $A_f = 0.0046 \text{ in.}^2$ and $D_o = 0.1145 \text{ in.}$ —use Drill No. 33 (0.1130 in.) with $A_o = 0.0100 \text{ in.}^2$. If it is assumed that there is no jet contraction, the injection velocities will be

$$v = C_d \sqrt{2 g_0 \Delta p / \rho}$$

$$v_f = 0.75 \sqrt{2 \times 32.2 \times 80 \times 144 / 60.5} = 83 \text{ ft/sec}$$

$$v_o = 0.75 \sqrt{2 \times 32.2 \times 80 \times 144 / 94} = 66.7 \text{ ft/sec}$$

These velocities have magnitudes that promise to give good injection and justify the original assumption of 80 psi injection drop. The injection angles are now to be chosen so that the resultant momentum will be in an axial direction. This is done in accordance with Equation 9-11 and by arbitrarily selecting the angle of inclination of the oxidizer jet at 20° . The symbols below are the same as in Equation 9-11.

$$\sin \gamma_f = r (v_o / v_f) \sin \gamma_o = 2.75 \times (66.7 / 83) \sin 20^\circ = 0.75$$

The fuel injection angle $\gamma_f = 48.6$ degrees. The following quantities have now been determined for the injector:

Injector Design Parameter	Fuel	Oxidizer
Flow (total propellant flow = 4.88 lb/sec)	1.30 lb/sec	3.58 lb/sec
Volume flow	37.1 in. ³ /sec	65.9 in. ³ /sec
Pressure drop through injector	80 psi	80 psi
Injection velocity	83 ft/sec	66.7 ft/sec
Number of injection holes	8	8
Diameter of each hole	0.077 in.	0.1145 in.
Angle of hole with nozzle axis	+48.6 deg	-20 deg
Total injection area	0.0372 in. ²	0.0822 in. ²

4. Heat Transfer. This thrust chamber is to be regeneratively cooled. Although it has been possible to calculate approximately the heat-transfer film coefficients of the gas layer, their accuracy is questionable. Therefore they will not be determined in this example. Accurate heat-transfer data have to be determined by tests. However, the average wall temperature of the chamber will be estimated and the cooling jacket will be designed so that the assumed average heat flow (1 Btu/in.² sec) can safely be absorbed in the coolant. The total heat transfer is the product of the average heat-transfer rate per unit area \bar{q} and the inside chamber and nozzle surface areas of 100 in.². The total heat transfer = $Q = 100 \text{ Btu/sec}$.

Either the oxidizer or the fuel can be used as coolant. In this case the fuel is to be preferred, because it is noncorrosive, because it requires a smaller and, therefore, lighter cooling jacket, and because, as shown below, its cooling capacity is adequate. The transferred heat to be absorbed by the cooling fluid is from Equation 4-13. In English units both \dot{w} and \bar{c} are defined in terms of weights.

$$Q = A\bar{q} = \dot{w}_f \bar{c} \Delta T$$

For aniline the average specific heat \bar{c} at the temperature in question has a value of 0.55 Btu/°F lb. The mean coolant temperature rise is therefore

$$\Delta T = A\bar{q}/(\dot{w}_f \bar{c}) = 100 \times 1/(1.30 \times 0.55) = 140^\circ\text{F}$$

This temperature rise is not excessive, and the fuel therefore appears to be satisfactory as a coolant. If the fuel was originally at 60°F, the temperature at which the fuel enters from the cooling jacket into the injector is therefore approximately 60 + 140 = 200°F. As can be seen, this temperature is well below the boiling point of the fluid (364°F), and there is little danger of any local boiling within the cooling jacket. This temperature was used in estimating the proper specific gravity of the injected fuel.

The film coefficient for the coolant liquid will now be evaluated. The following values are needed for the coolant (aniline) and are averaged over the temperature range.

Density	60.5 lb/ft ³
Thermal conductivity	2.7×10^{-5} Btu/sec ft ² °F/ft
Viscosity	3.1×10^{-5} lb-sec/ft ²
Specific heat	0.55 Btu/lb °F

The evaluation of this film coefficient depends on the Reynolds number, the Prandtl number, and the coolant velocity and the equivalent hydraulic diameter of the cooling coil passage have to be known. The cooling coil passage will be rectangular in cross section and will wind around the chamber in a helical fashion. By assuming an average coolant velocity of 15 ft/sec, the cross-sectional area for a single helix in the chamber wall is

$$A = Q/v = 37.1/(12 \times 15) = 0.206 \text{ in}^2.$$

In order to have a low coolant pressure drop and a relatively simple shape to manufacture, a double helix coolant passage of rectangular cross section was chosen. The dimensions of a cross section through a single helix might then be approximately $\frac{1}{8} \times \frac{1}{16}$ in. The value of D to be used in the calculation of the Reynolds number equals 4 times the hydraulic radius. From Equation 4-12 the coolant film coefficient is

$$\begin{aligned} h_f &= 0.023 \bar{c} \frac{\dot{w}}{A} \left(\frac{Dv\rho}{\mu g} \right)^{-0.2} \left(\frac{\mu g \bar{c}}{\kappa} \right)^{-0.67} = 0.023 \times 0.55 \times \frac{1.3}{0.206} \\ &\times \left(\frac{0.0183 \times 15 \times 60.5}{3.1 \times 10^{-5} \times 32.2} \right)^{-0.2} \left(\frac{3.1 \times 10^{-5} \times 0.55 \times 32.2}{2.7 \times 10^{-5}} \right)^{0.67} \\ &= 0.00154 \text{ Btu/in.}^2 \text{ sec}^\circ\text{R} \end{aligned}$$

The heat transfer across the liquid coolant film is obtained from Equation 4-6. It is to be solved for the wall temperature on the liquid side

$$T_{w,l} = \bar{q}/h_f + T_f = 1.0/0.00154 + \frac{1}{2}(60 - 200) = 779^\circ\text{F}$$

and gives an average temperature estimate of the outside wall surface of the inner chamber wall. If the wall is assumed to be 0.075 in. thick, the equivalent film coefficient for the wall will be $h_w = \kappa_w/l_w$. Stainless steel has been selected for chamber material

because of its good erosion resistance. For stainless steel the conductivity $\kappa = 1.3$ Btu/in.² hr °R/in.

$$h_w = 1.3 / (0.075 \times 3600) = 0.0048 \text{ Btu/in.}^2 \text{ sec } ^\circ\text{R}$$

The average wall temperature on the gas side of the chamber is therefore

$$T_{wg} = 1.0 / 0.0048 + 779 = 987^\circ\text{F}$$

The average wall temperature on the gas side is considered safe for stainless steel. The throat section in an actual design should be checked separately to determine its heat-transfer characteristics. At the throat the coolant helix cross section is to be decreased in order to increase the local coolant velocity to about 30 ft/sec.

5. Cooling Coil Loss. In order to select the appropriate feed pressure for the fuel, it is necessary to estimate the hydraulic losses in the cooling coil that surrounds the chamber and nozzle. According to Equation 9-3, which has to be corrected by g_0 for using English unit, the loss is

$$\Delta p = f(L/D) \rho v^3 / (2g_0)$$

where Δp is the friction loss (lb/ft²), L is the length of coil (ft), f is the friction coefficient, D is the diameter or $4 \times$ hydraulic radius (0.22/12 ft), ρ is the density at jacket temperature (lb/ft³), and v is the velocity in cooling passage (15 ft/sec). There are two identical helix cooling coils in parallel. The length L is the total length of the cooling helix, when unwound from the chamber jacket and nozzle. If it is assumed that there is a wall 0.075 in. wide between individual cooling passages, there will be a total of 12 turns in each helix, giving an approximate total length of 83 in. These quantities can be more accurately determined when the cooling coil is developed from scaled drawings; for this example the above can be considered adequate for estimating the pressure drop. The friction factor f is a function of Reynolds number and can be found from pipe flow data to be 0.038 for clean steel pipes at a Reynolds number of 16,600. The friction coefficient f has to be corrected for the curvature effect. An empirical correction factor for small thrust chamber, using aniline cooling, is 1.19. Since the coolant velocity near the nozzle throat is increased to about 30 ft/sec, the average cooling velocity in the helix is about 21 ft/sec. The friction loss in the fuel cooling jacket is therefore from Equation 9-3

$$\Delta p_f = 0.038 \times 1.19 \times (83/0.22) (60.5/144) (21^2/64.4) = 49.1 \text{ psi}$$

The thrust chamber supply pressure is equal to the sum of the chamber pressure and the pressure losses in the cooling jacket and the injector.

$$p_o = 300 + 80 = 380 \text{ psi}$$

$$p_f = 300 + 80 + 49.1 = 429 \text{ psi}$$

The fuel has to be supplied at 429 psi and the oxidizer at 380 psi. The feed system has to be so controlled that it will supply the propellants at these pressures and an oxidizer flow rate of 3.58 lb/sec and a fuel flow rate of 1.30 lb/sec.

6. Wall Thickness. The thickness of the cylindrical shell is chosen in conformance with stress values. For a cylinder under radial pressure:

$$\Delta p D = 2t_w s$$

where Δp is the pressure difference across jacket, D is the mean diameter of cylinder, t_w is the thickness of cylinder wall, and s is the working stress. For certain stainless steels at elevated temperatures the yield stress may be taken at 25,000 psi. Applying a safety factor of 2 to account for pressure surges during starting and stopping, for other loads, and for uneven thermal expansion, the working stress is 12,500 psi. The worst

condition occurs when a thrust chamber is restarted while the inner wall is still hot (assume $\Delta p = 420$ psi)

$$t_w = \Delta p D / 2s = 420 \times 5.1 / (2 \times 12,500) = 0.086 \text{ in.}$$

This is the minimum tolerable thickness; actually, the thickness should be somewhat heavier to allow for welding factors, buckling tendency, and stress concentration. The thickness, for simplicity's sake, will be made uniform throughout, that is, also in the nozzle section. The value of 0.109 in. has been chosen arbitrarily. A similar calculation should be carried out for the outer chamber shell; the thickness for the outer shell was found to be 0.062 in.

4. Gas Pressure Feed System

As described in Chapter 7 and Figures 1-3 and 7-2, these simple systems expel liquid propellants from high-pressure tanks by displacing them with a high-pressure gas. In an actual propulsion system installation, the pressurized gas may be required to also perform other functions, such as the operation of valves and controls. The first part of gas leaving the high-pressure-gas storage tank is at ambient temperature. If the high-pressure gas expands rapidly, then the gas remaining in the tank undergoes essentially an isentropic expansion, causing the temperature of the gas to decrease steadily; the last portions of the pressurizing gas leaving the tank are very much colder than the ambient temperature and readily absorb heat from the piping and the tank walls. The Joule-Thompson effect causes a further small temperature change.

A *simplified analysis* of the pressurization of a propellant tank can be made on the basis of the conservation of energy principle by assuming an adiabatic process (no heat transfer to the walls) and by assuming the initial weight of gas in the piping and the propellant tank to be small. Let the initial condition in the gas tank be given by subscript 0 and the instantaneous conditions in the gas tank by subscript g and in the propellant tank by subscript p . The gas energy after and before propellant expulsion is:

$$m_g c_v T_g + m_p c_v T_p + p_p V_p = m_0 c_v T_0 \quad (9-12)$$

The work done by the gas in displacing the propellants is given by $p_p V_p$. Using Equations 3-3 to 3-5, the initial storage gas mass m_0 may be found.

$$c_v p_g V_0 / R + c_v p_p V_p / R + p_p V_p = m_0 c_v T_0$$

$$m_0 = (p_g V_0 + p_p V_p k) / (R T_0) \quad (9-13)$$

This may be expressed as

$$m_0 = \frac{p_g m_0}{p_0} + \frac{p_p V_p}{R T_0} k = \frac{p_p V_p}{R T_0} \left(\frac{k}{1 - p_g / p_0} \right) \quad (9-14)$$

The first term in this equation expresses the weight of gas required to empty a completely filled propellant tank, if the gas temperature is maintained at the

initial storage temperature T_0 . The second term expresses the availability of the storage gas as a function of the pressure ratio through which the gas expands.

Heating of the pressurizing gas reduces the storage requirements and can be accomplished by putting a heat exchanger into the gas line. Heat from the rocket thrust chamber, the exhaust gases, or from other devices can be used as energy sources. The reduction of storage gas weight depends largely on the type and design of the heat exchanger.

If the expansion of the high pressure gas proceeds slowly (e.g., with an attitude control propulsion system with many short pulses over a long period of time), then the gas expansion comes close to an isothermal process; heat is absorbed from the vehicle and the gas temperature does not decrease appreciably.

The heating and cooling effects of the tank and pipe walls, the liquid propellants, and the valves on the pressurizing gas are difficult to evaluate analytically and need to be experimentally investigated. The design of storage tanks therefore allows a reasonable excess of pressurizing gas to account for these effects, for ambient temperature variations, and for the absorption of gas by the propellant. Equation 9-14 is therefore valid only under ideal conditions.

EXAMPLE 9-2. What air tank volume is required to pressurize the propellant tanks of a 9000 N thrust rocket thrust chamber using 90% hydrogen peroxide as a monopropellant at a chamber pressure of 2.00 mega pascals for 30 sec in conjunction with a solid catalyst? The air tank pressure is 14 mega pascals and the propellant tank pressure is 3.0 mega pascals.

Solution. The exhaust velocity is 1300 m/sec and the required propellant flow can be found from Equation 3-34 ($\zeta_d = 1.06$):

$$\dot{m} = \zeta_d F/c = 1.06 \times 9000/1300 = 7.34 \text{ kg/sec}$$

The total propellant required is $m = 7.34 \text{ kg/sec} \times 30 \text{ sec} = 220 \text{ kg}$. The density of 90% hydrogen peroxide is 1388 kg/m^3 . The propellant volume is $220/1388 = 0.158 \text{ m}^3$. With 5% allowed for ullage and excess propellants, Equation 9-14 gives the required weight of air ($R = 230 \text{ J/kg}^\circ\text{K}$; $T_0 = 290^\circ\text{K}$; $k = 1.40$) for displacing the liquid.

$$m_0 = \frac{p_p V_p}{RT_0} \frac{k}{1 - (p_g/p_0)} = \frac{3.0 \times 10^6 \times 0.158 \times 1.05 \times 1.4}{230 \times 290 \times [1 - (3/14)]}$$

$$= 19.95 \text{ kg of compressed air.}$$

With an additional 5% allowed for excess gas, the high pressure tank volume will be,

$$V_0 = m_0 RT_0/p_0 = 1.05 \times 19.95 \times 230 \times 290/(14 \times 10^6)$$

$$= 0.0998 \text{ m}^3.$$

The pressures in the gas storage tank are usually chosen so as to permit a small and lightweight gas tank design. The weight of the tank for storing the compressed gas depends on the density of the gas, its maximum storage temperature, and its value of k , its shape, and is approximately inversely proportional to the molecular weight of the gas selected. The storage pressure ordinarily ranges between 12 and 35 mega pascals and is usually 4 to 8 times as high as the propellant tank pressure.

Table 9-4. A Comparison of Propellant Expulsion Methods for Spacecraft Hydrazine Tanks*

Selection Criteria	Positive Expulsion Devices			
	Elastomeric Diaphragm (hemispherical)	Inflatable Elastomeric Bladder (spherical)	Metallic Diaphragm (hemispherical)	Surface Tension Screens
Application history	Extensive	Extensive	Limited	Extensive in short-life satellites None in long-life satellites
Weight (normalized)	1.0	1.1	1.2	0.9
Expulsion efficiency	Excellent	Good	Fair	Good†
Long service life	Excellent	Excellent	Excellent	Unproven
Preflight check	Leak test	Leak test	Leak test	None

* Adapted from Reference 9-1.

† Relates to hydrazine in applications where the disturbing accelerations are less than 0.1g, typically 10^{-3} to 10^{-7} g.

Air is preferred as a *pressurizing gas* because it is readily available. For propellants that can react with their pressurizing gases, an inert gas (for example, nitrogen to pressurize fuel) must be used unless provisions are made to separate the chemically active gas from the propellant. This separation may be accomplished by means of a collapsible, flexible bag within the propellant tank.

In nonspinning spacecraft, some form of positive control of the location of the liquid within the tank is required, since propellant can leave the tank outlet and float or mix with the pressurizing gas during zero-g and negative-g conditions. Table 9-4 gives a brief comparison of four of the more common *expulsion methods*. Expulsion efficiencies, namely, the percentage of the propellant that can be expelled from the tank, ranges from 96 to 99% for the four methods. Elastomeric diaphragms and inflatable bladders are thoroughly flight-proven. *Surface tension screens* for hydrazine are made from 300 series stainless steel wire woven into a close mesh screen resembling that used for filtering gasoline.

Pressurized propellant feed systems exist in two general arrangements for use with attitude control rockets; one pressurizes the propellant tank or tanks with nitrogen stored in a separate tank and the other carries the pressurant in the propellant tank. In pressurizing liquid oxygen, some of the pressurizing gas, such as air or nitrogen, is condensed or dissolved and therefore is not fully

effective as a pressurizing agent. A low-freezing inert gas, such as helium, has been used for forcing liquid cryogenics out of tanks. In general, about $2\frac{1}{2}$ times as much nitrogen weight is needed for pressurizing liquid oxygen, if compared to the nitrogen needed for displacing an equivalent volume of water at the same pressure. Frozen air can form explosive mixtures with liquid hydrogen.

The required weight of pressurizing gas and, thus, the size and weight of the gas storage container can be significantly reduced by a "tail-off" pressure decay; here the pressurizing gas supply is shut off or exhausted while a major portion of the liquid propellants is still in the propellant tanks. These remaining propellants are then expelled by the adiabatic expansion of the gas already in the propellant tanks. The tank pressure and the chamber pressure decrease or progressively decay during this adiabatic expansion period.

The exact amount of propellant remaining in the tank is difficult to estimate because a thin film of propellant can remain on all internal surfaces; sloshing and vehicle maneuvers may require a thrust termination prior to propellant exhaustion to prevent the tank outlet from becoming uncovered and gas from being admitted to the thrust chamber. Anti-slosh baffles and anti-vortex baffles have been successfully employed inside tanks for vehicles with modest side acceleration.

Some pressure feed systems can be prefilled with propellant and pressurizing agent at the factory and stored in readiness for operation. Compared to a solid propellant rocket unit these storable prepackaged liquid propellant pressurized feed systems offer advantages in long term storeability, and resistance to transportation vibration or shock. The Army's *Lance* missile uses such a system.

Chemical pressurization permits injecting a small amount of fuel or other suitable spontaneously ignitable chemical into the oxidizer tank, or vice versa. While ideally this type of pressurization system is very small and light, in practice it has not usually given reproducible tank pressures, because the sloshing of propellant in the tank during vehicle maneuvers has caused sudden cooling of the hot pressurizing gas and thus some erratic tank pressure changes.

The *thrust* of a pressurized gas rocket propulsion system is determined by the magnitude of the propellant flow, which, in turn, is determined by the gas pressure regulator setting. The propellant *mixture ratio* in this type of feed system is controlled by the hydraulic resistance of the liquid propellant lines and can usually be adjusted by means of variable or interchangeable restrictors. Further discussion of the adjusting of thrust and mixture ratio can be found in Section 8 of this chapter and in Example 9-4.

5. Turbopump Feed System

This feed system and its several cycles have been discussed in Chapter 7. Figures 7-3, 7-4, 7-5, and 9-1 and Table 9-5 show typical installations and

Table 9-5. Turbopump Characteristics

Engine Type	H-1		J-2	
	<i>Pumps</i>			
Propellant type	Oxidizer	Fuel	Oxidizer	Fuel
Propellant	L O ₂	RP-1	L O ₂	L H ₂
Pressure increase in pump (psi)	693	821	1069	1220
Head increase in pump (ft)	1444	2243	2172	38,337
Flow rate (lb/sec)	452.6	199.4	467.7	84.2
Impeller diameter (in.)	11	13.5		
Shaft speed (rpm)	5940	5940	8698	27,167
Efficiency(%)	75	71	80	73
Shaft power (hp)	1726	1165	2302	8587
Required NPSH (ft)	90	50	42.3	176
	<i>Turbine(s)</i>			
Shaft power (hp)	2975		2302	8587
Inlet pressure (psi) (Total)	445		89.3	652
Pressure ratio	18.35		2.65	7.20
Shaft speed (rpm)	28,924		8698	27,167
Inlet temperature (°F)	1200		768	1200
Turbine to pump gear ratio	4.885		—	—
Efficiency (%)	68		47	60
	<i>Gas Generator</i>			
Flow rate (lb/sec)	12.7		7.04	
Mixture ratio (oxidizer/fuel)	0.342		0.94	
Chamber pressure (psi)	465.9		682	

data. The principal components, namely, the turbine, the pumps, and the gas generator, are discussed in more detail in this section.

There are many different arrangements of turbines and pumps within a turbopump assembly. The pumps can be on the same shaft as the turbine (see Figure 9-15) or one or more gear trains can be interposed (see Figure 9-16). Fuel and oxidizer pumps can have separate individual turbines which can be driven by sending the working fluid through the turbines in series or in parallel. There are even variations of the arrangements of turbine, fuel pump, and oxidizer pump on the same shaft. The Space Shuttle main engine as shown in Figure 7-5 has two sets of turbopumps for each of the propellants, one each for raising the pressure a small amount to allow a good positive suction pressure on the pumps of the main fuel or oxidizer turbopump. The selection of any specific turbopump configuration depends on such factors as inlet conditions to the pumps and turbine, weight, past experience, performance