

Case Study: ParaShield and Skidbladnir

- Overview of ultra-low ballistic coefficient entry
- Project Skidbladnir design review slides
- Summary of flight operations



Graduate Design Class: Fall, 1988

- Six students in graduate class in Aeronautics and Astronautics at MIT
- Project summary: Design an alternative manned spacecraft to supplement/replace the shuttle in the event of another Challenger-type accident
- Had to be capable of launch on Delta II, Atlas, Titan IIIC (existing ELVs)



Parametric Analysis of Heating

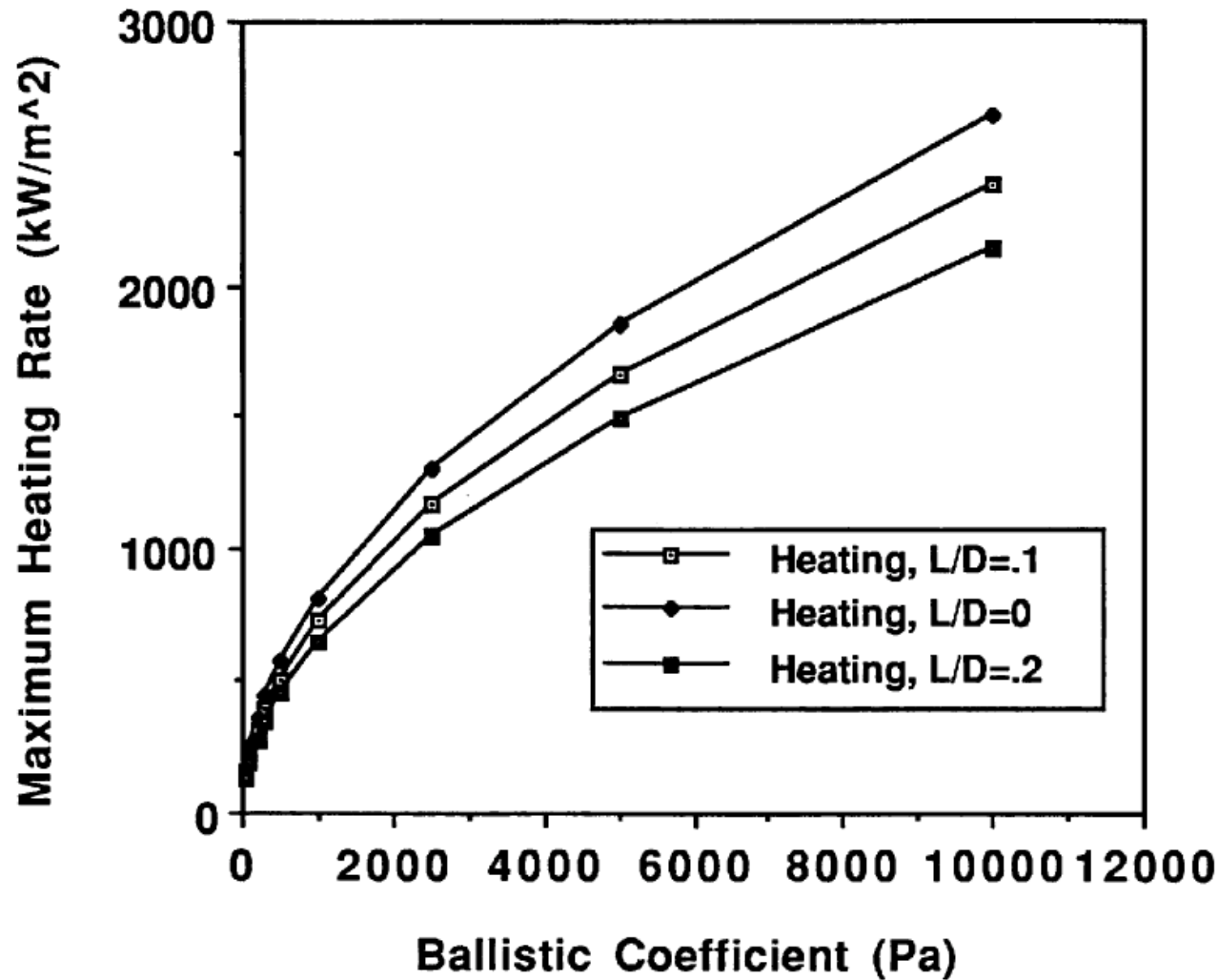

Parametric Analysis of Stagnation Temp

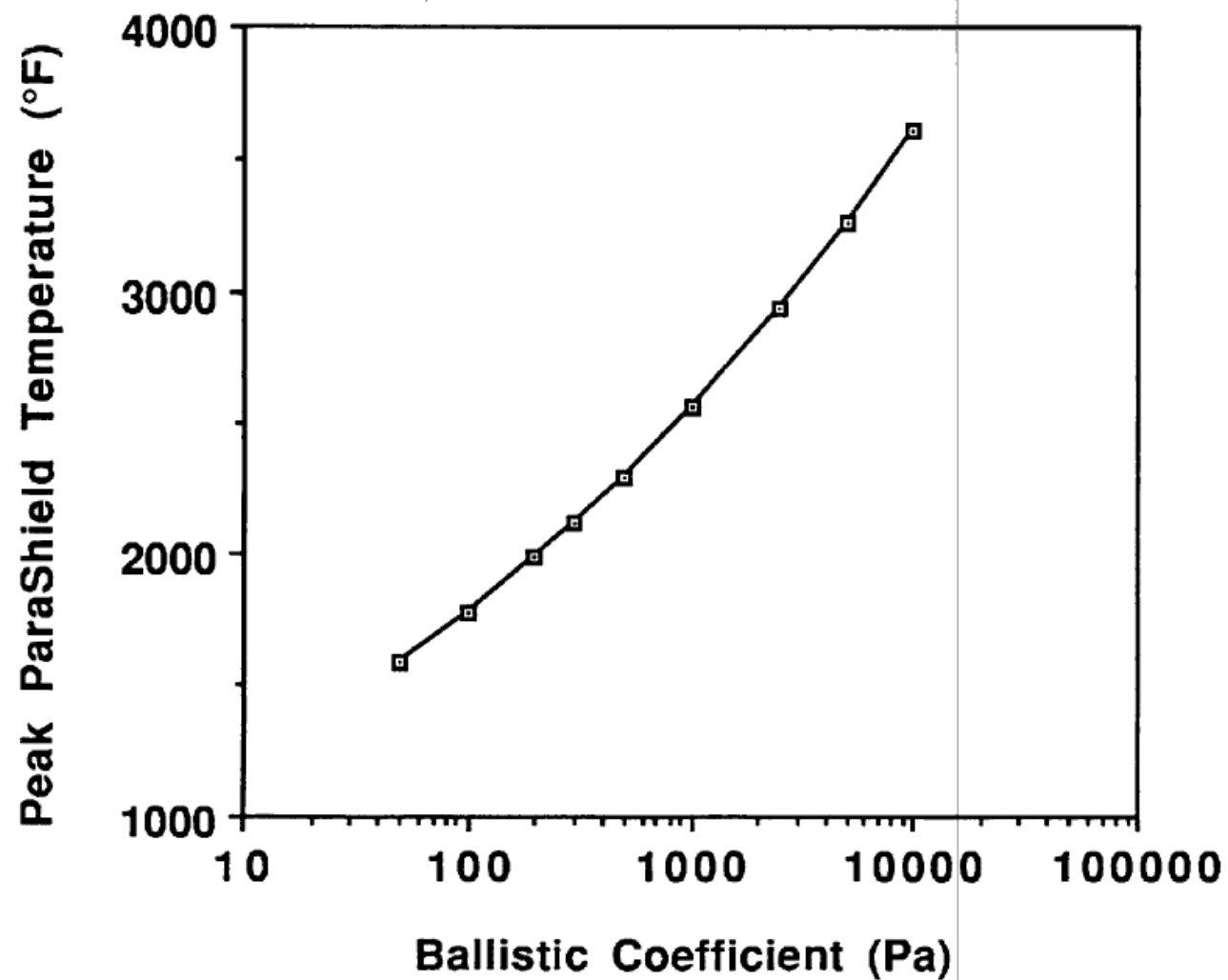

Parametric Analysis of Dynamic Pressure

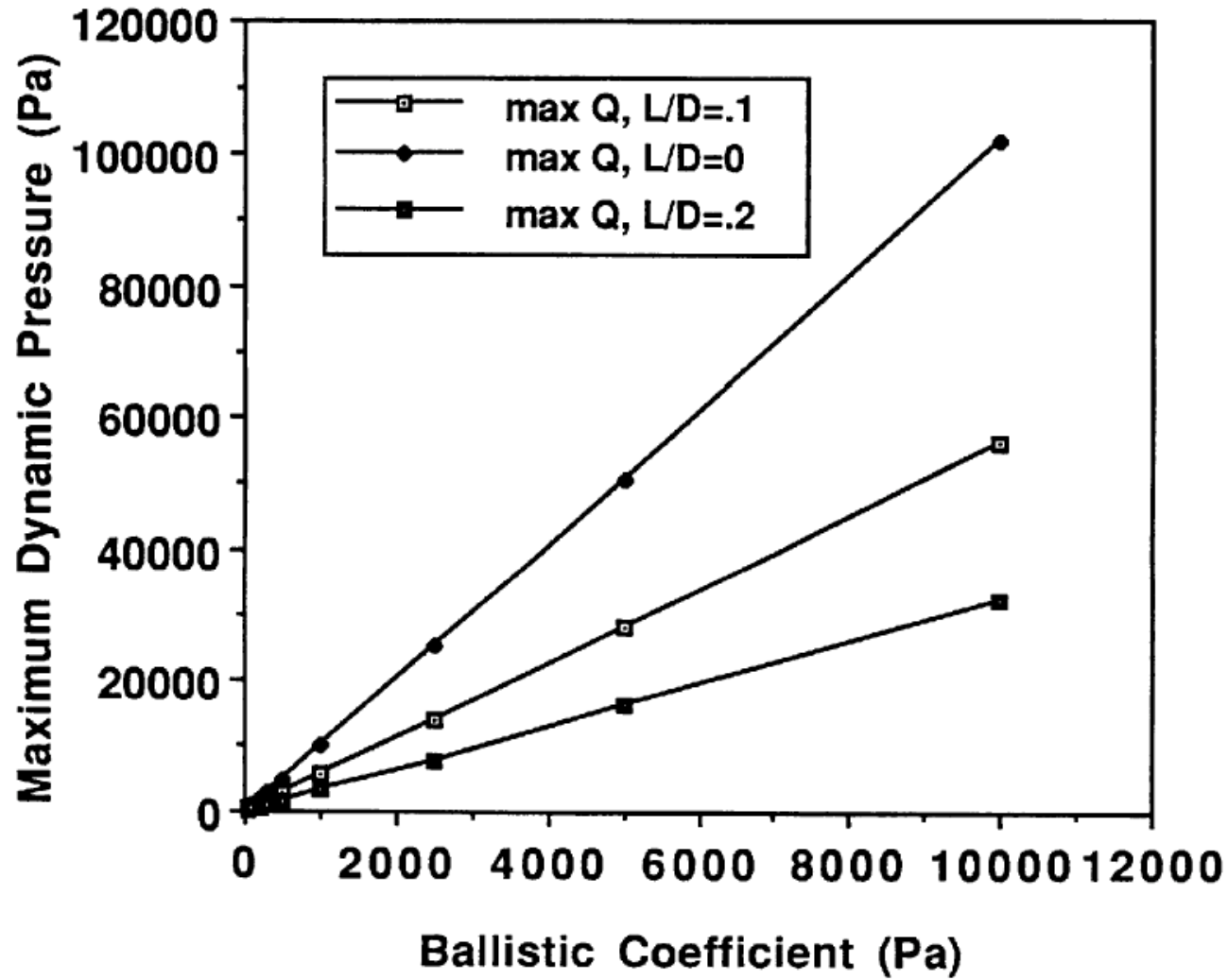

Parametric Analysis of Peak Deceleration

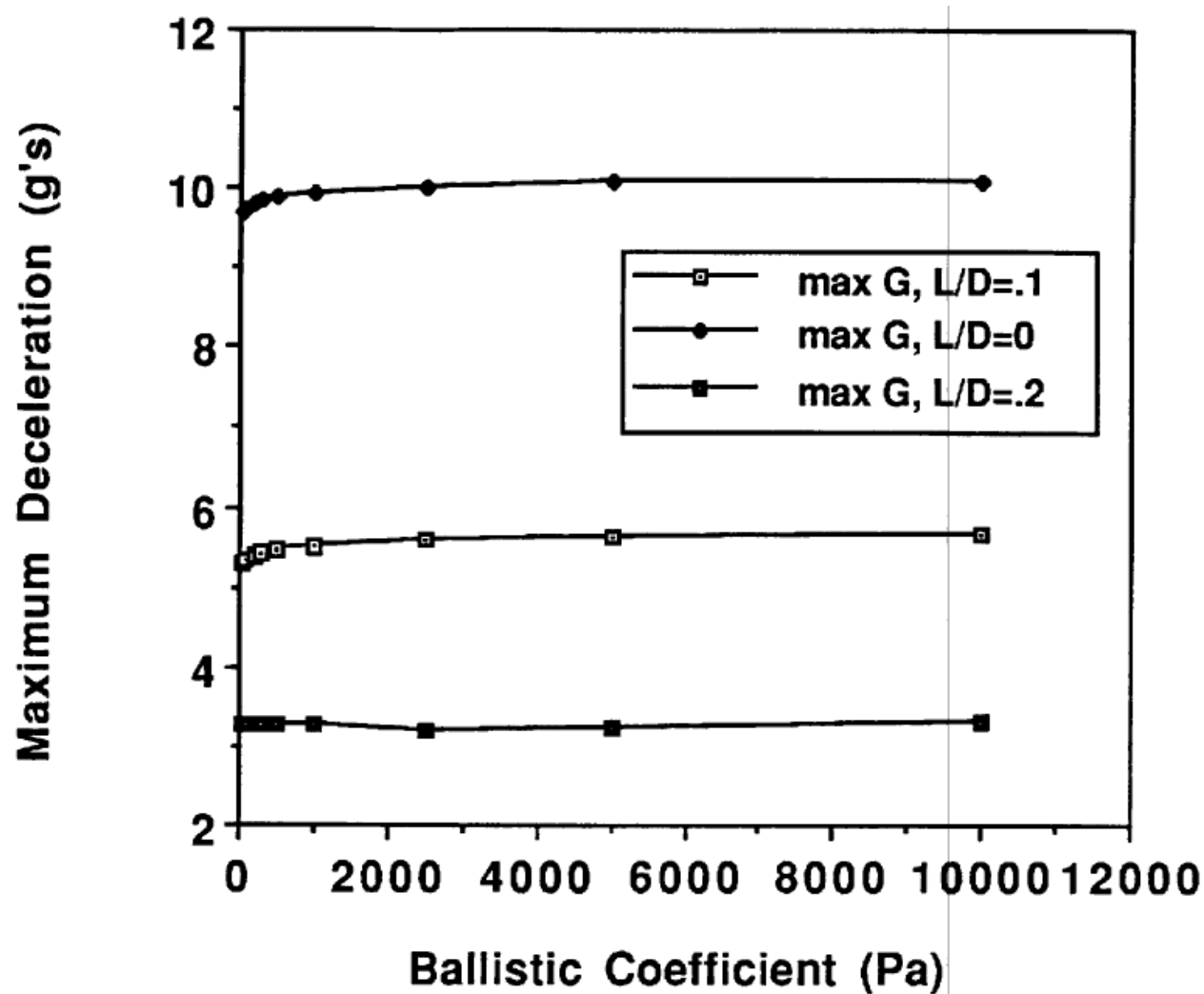

Comparison of Entry Trajectories

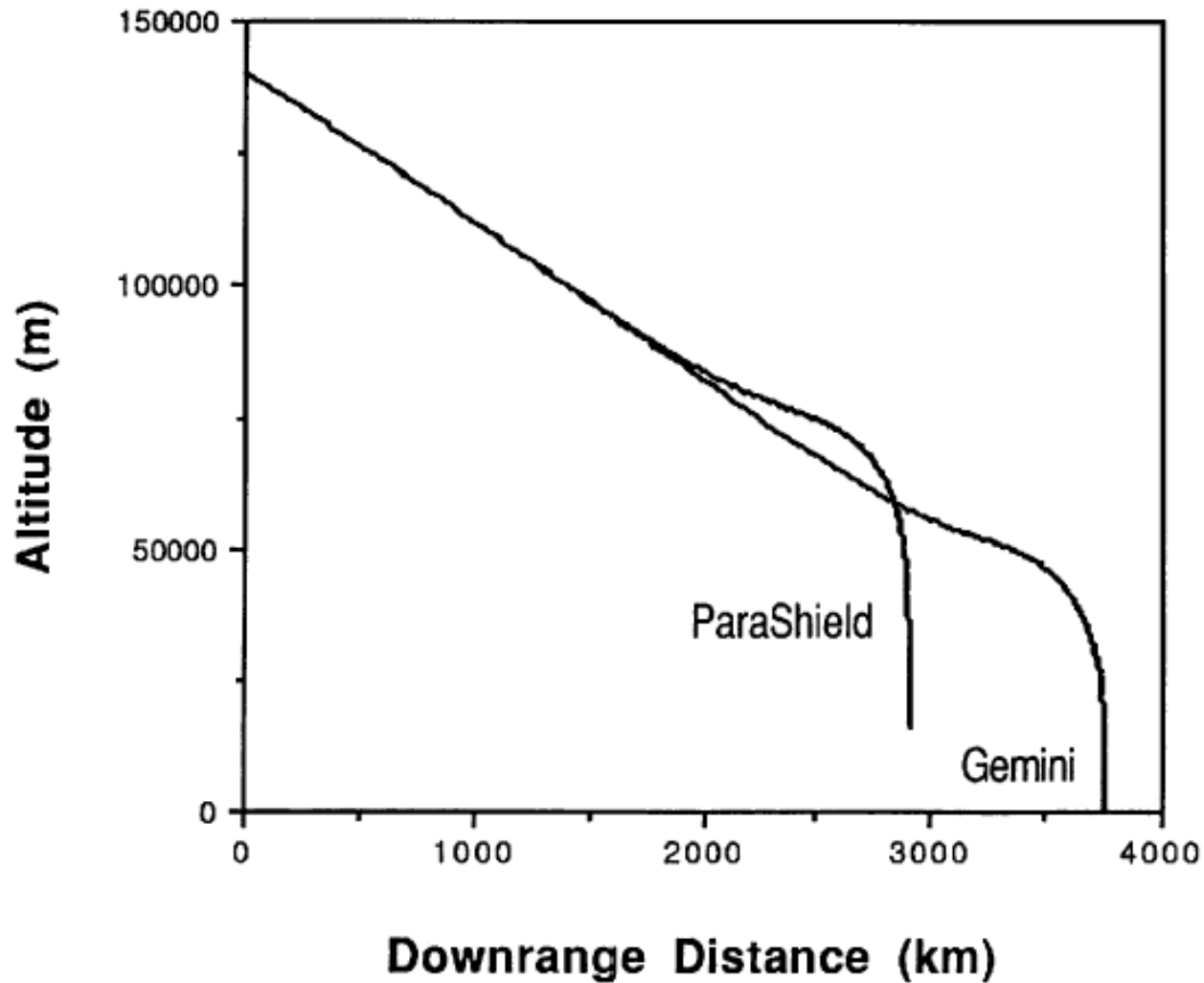

Comparison of Heat Shield Temperatures

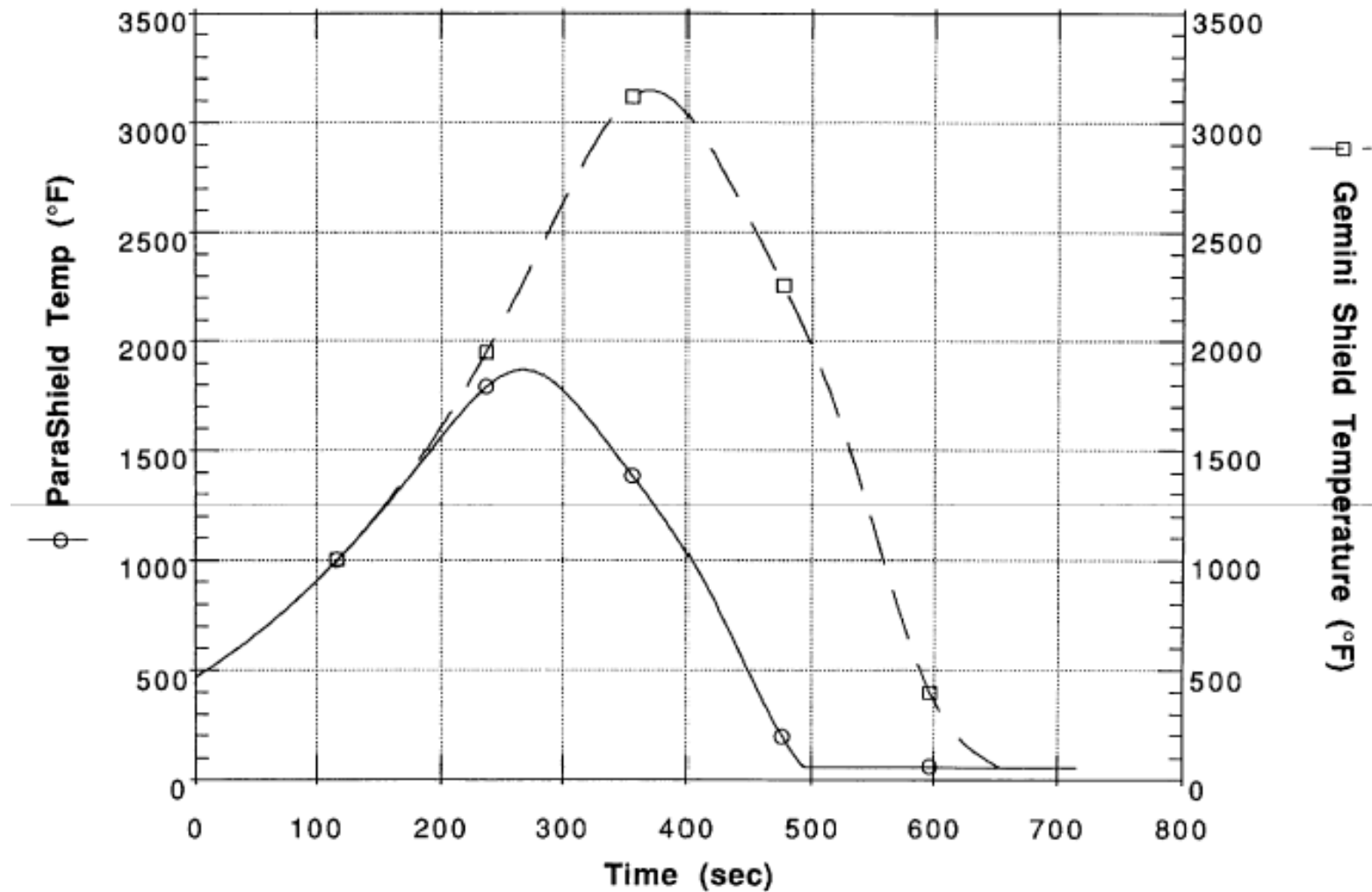

Comparison of Total Heat Loads

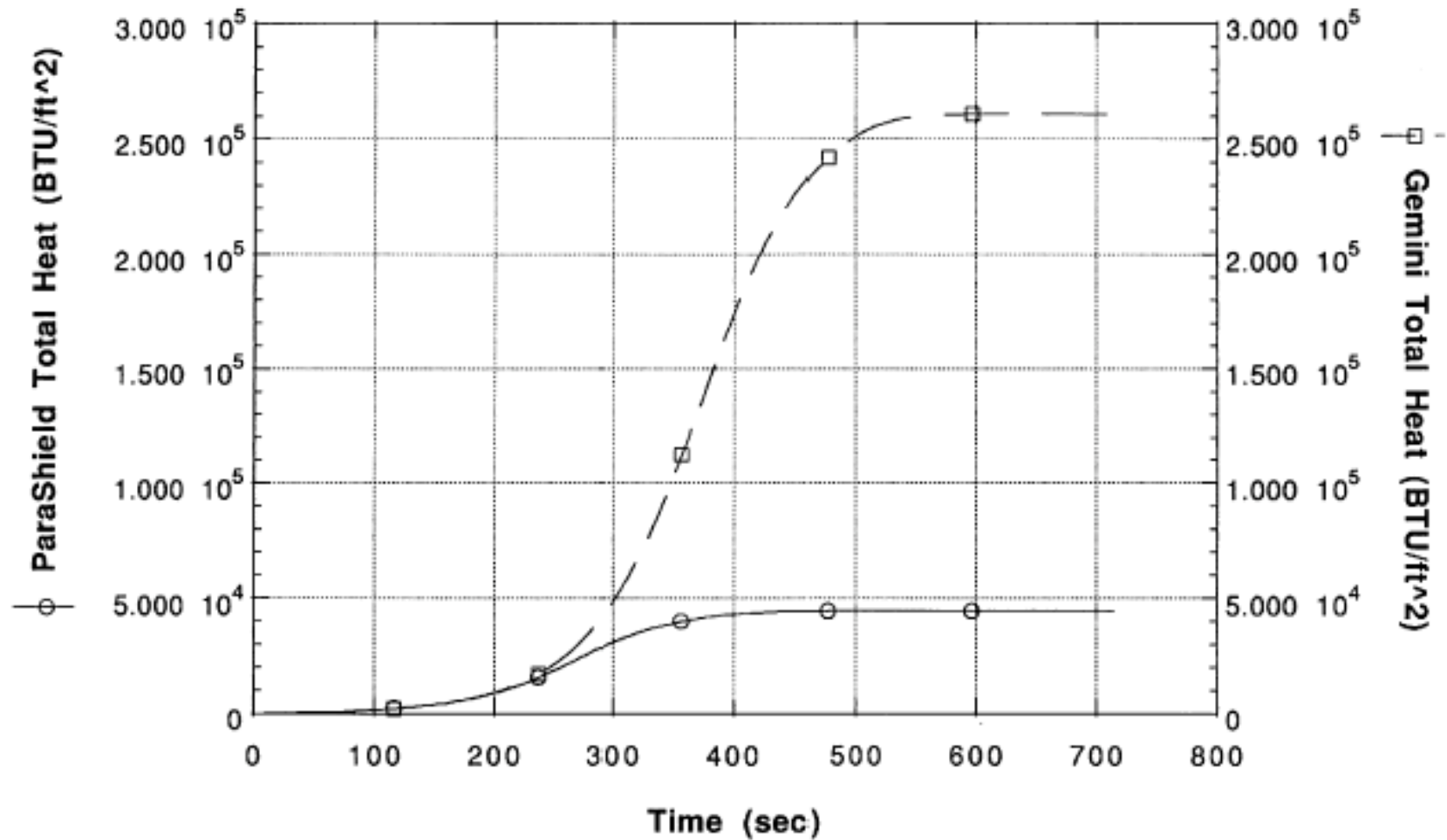

Project Skidbladnir:
Flight Test of the
ParaShield Concept

Space Systems Laboratory
Massachusetts Institute of
Technology

Introduction

Engineering Objectives

- **Provide a flight demonstration of ParaShield concept**
- **Verify models of**
 - **flight dynamics**
 - **aerothermodynamics**
 - **structural loads**
- **Collect imaging data on launch vehicle separation, lee-side ionization, and landing phase**
- **Carry commemoratives for payload**

Configuration

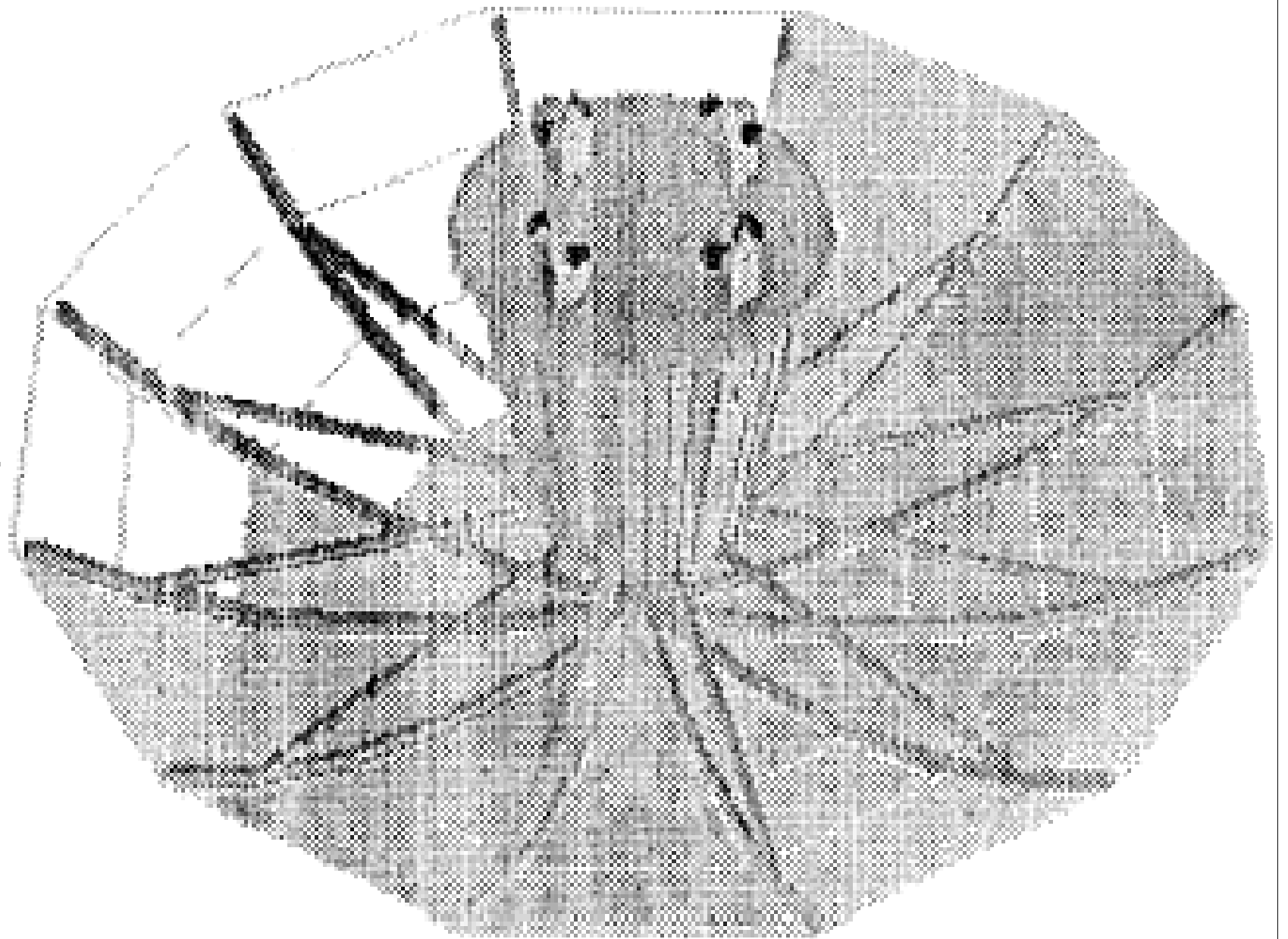

Mass Budget

All masses in kilograms

Payload		7
Avionics		5.1
Sensors	(1.1)	
Instruments	(2.0)	
Electronics	(2.0)	
Mechanisms		20.0
Deployment	(18.0)	
Recovery	(2.0)	
Structure		79.5
Thermal Protection	(38.9)	
Capsule	(40.6)	
Power		14.0
Propulsion		21.5

Total

147.1

Deployment Performance Summary

Time to open: 10-15 sec (one motor)

5-10 sec (two motors)

Required Power: 12 A @ 12 V (1 motor)

24 A @ 12 V (2 motors)

Deployment force 1 lbf each strut at start of deployment

at tip of strut: 250 lbf each strut at end of deployment

Trajectory

Trajectory Assumptions

Vehicle Assumptions

$$m = 150 \text{ kg}$$

$$\beta = 215.7 \text{ Pa}$$

$$L/D = .177$$

Flight Dynamics Assumptions

ParaShield deployment occurs 60 sec after passing 100 km mark

$$\text{Time} = 174 \text{ sec}$$

$$\text{Altitude} = 148.8 \text{ km}$$

$$\text{Velocity} = 832 \text{ m/sec}$$

$$\text{Flight path angle} = 40.8^\circ$$

Aerodynamic Similarity to Viking Lander

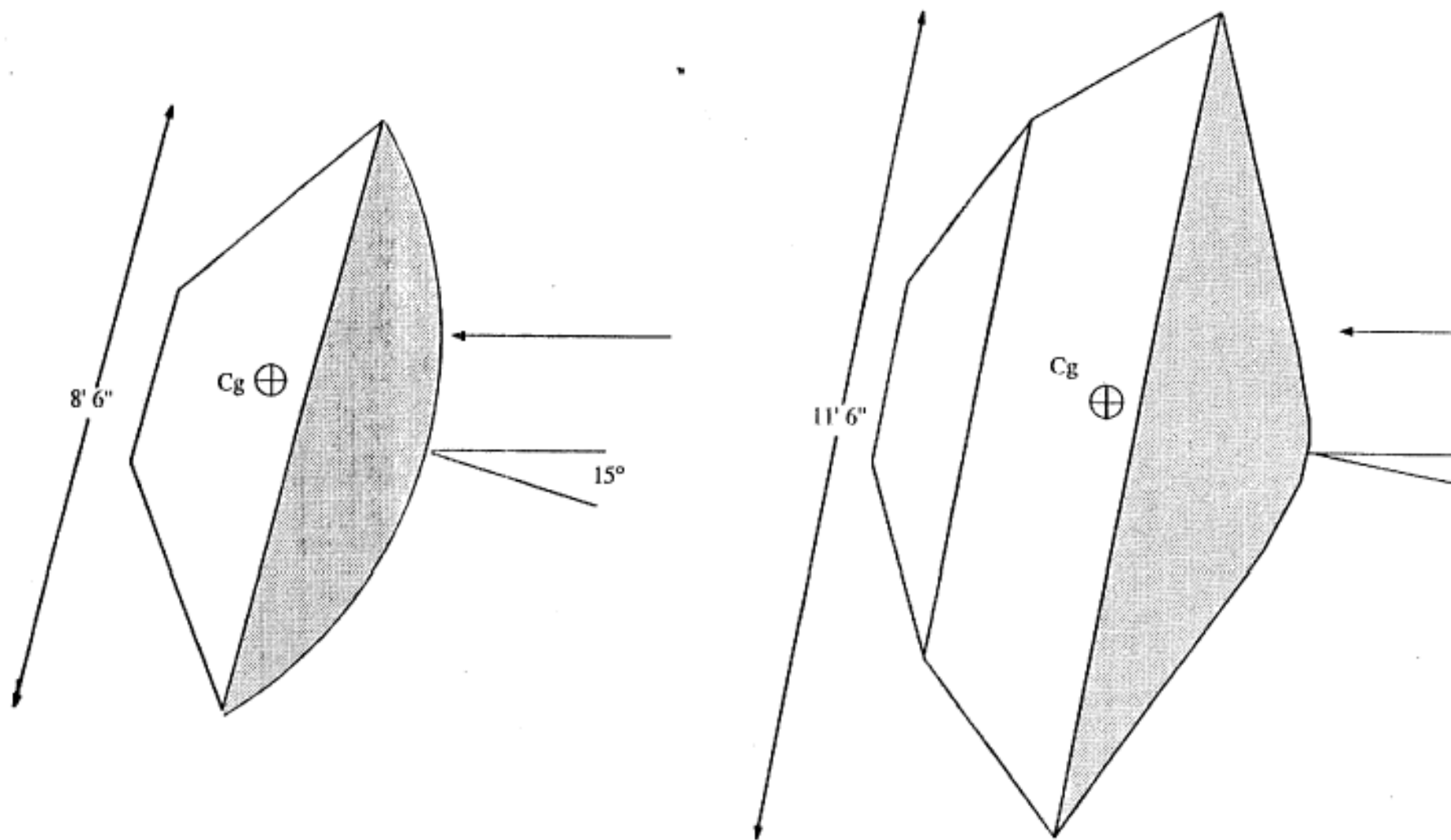

Comparison of Drag Coefficients: Parashield (Calculated) vs. Viking Lander (Wind Tunnel)

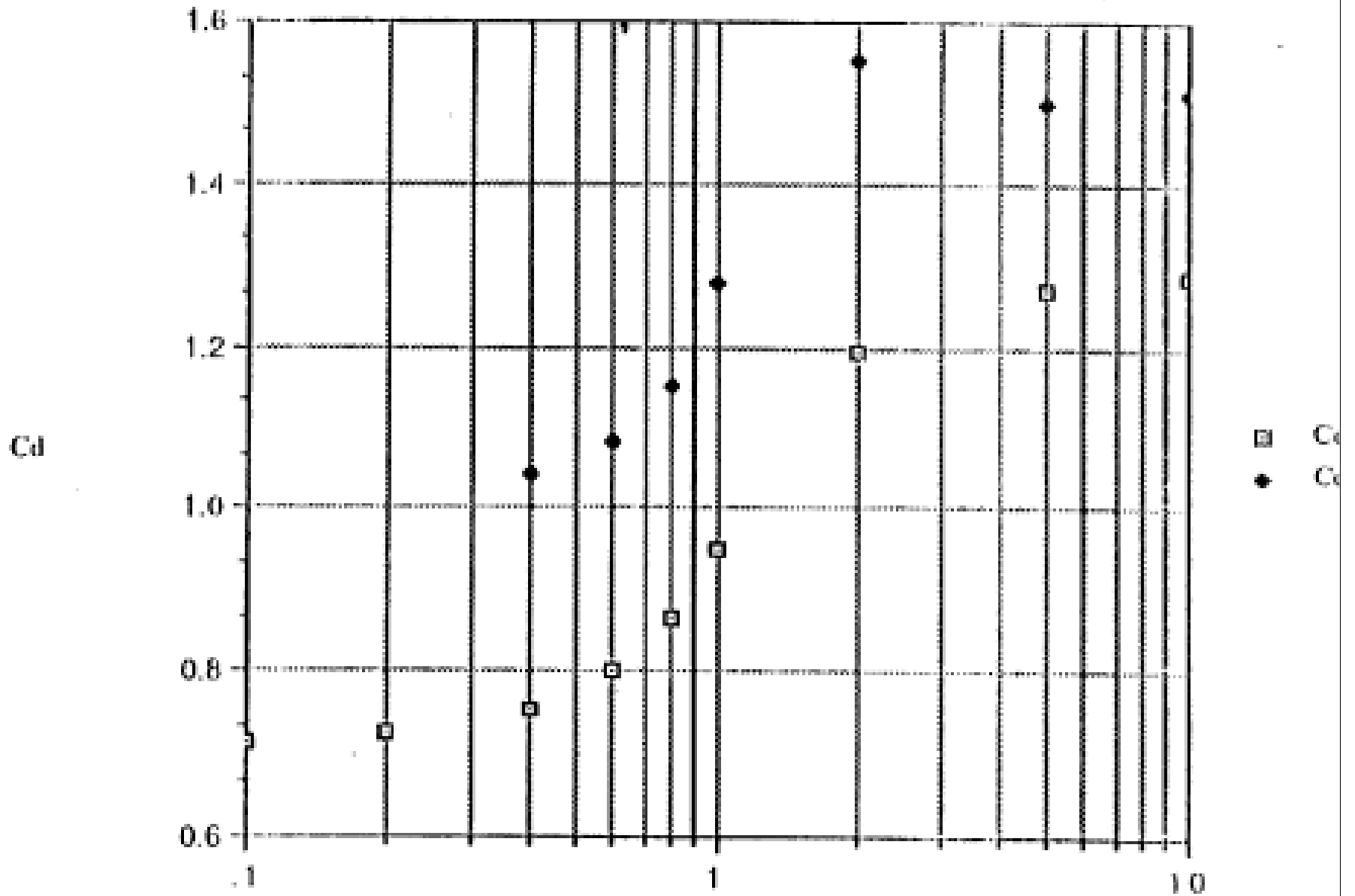

**AMROC Trajectory
(Roll Angle = 0)**

--- Mach Number — Altitude

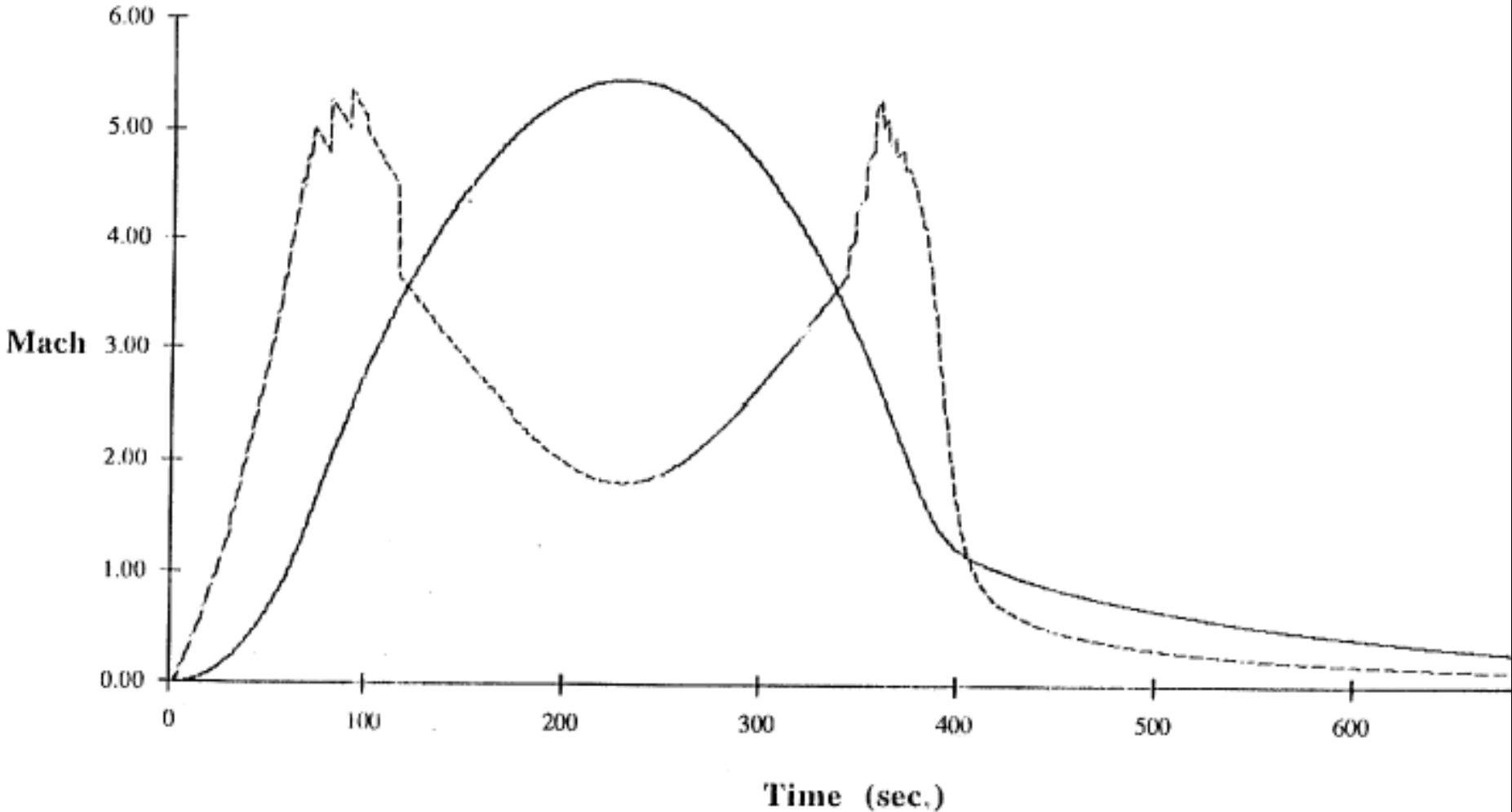

AMROC Trajectory (Roll Angle = 0)

--- Dynamic Pressure — Heating Rate

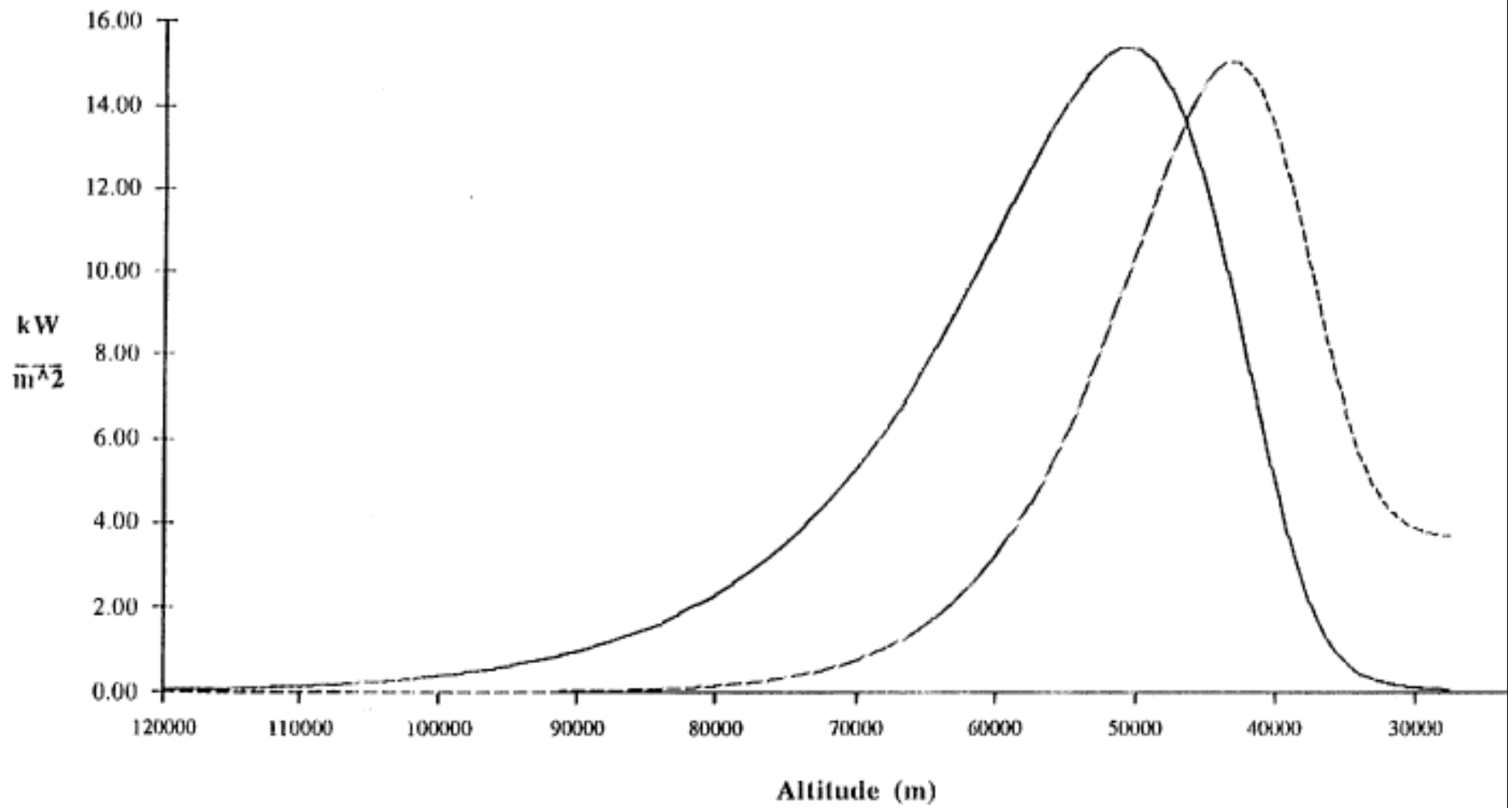

AMROC Trajectory (Roll Angle = 180°)

--- Dynamic Pressure — Heating Rate

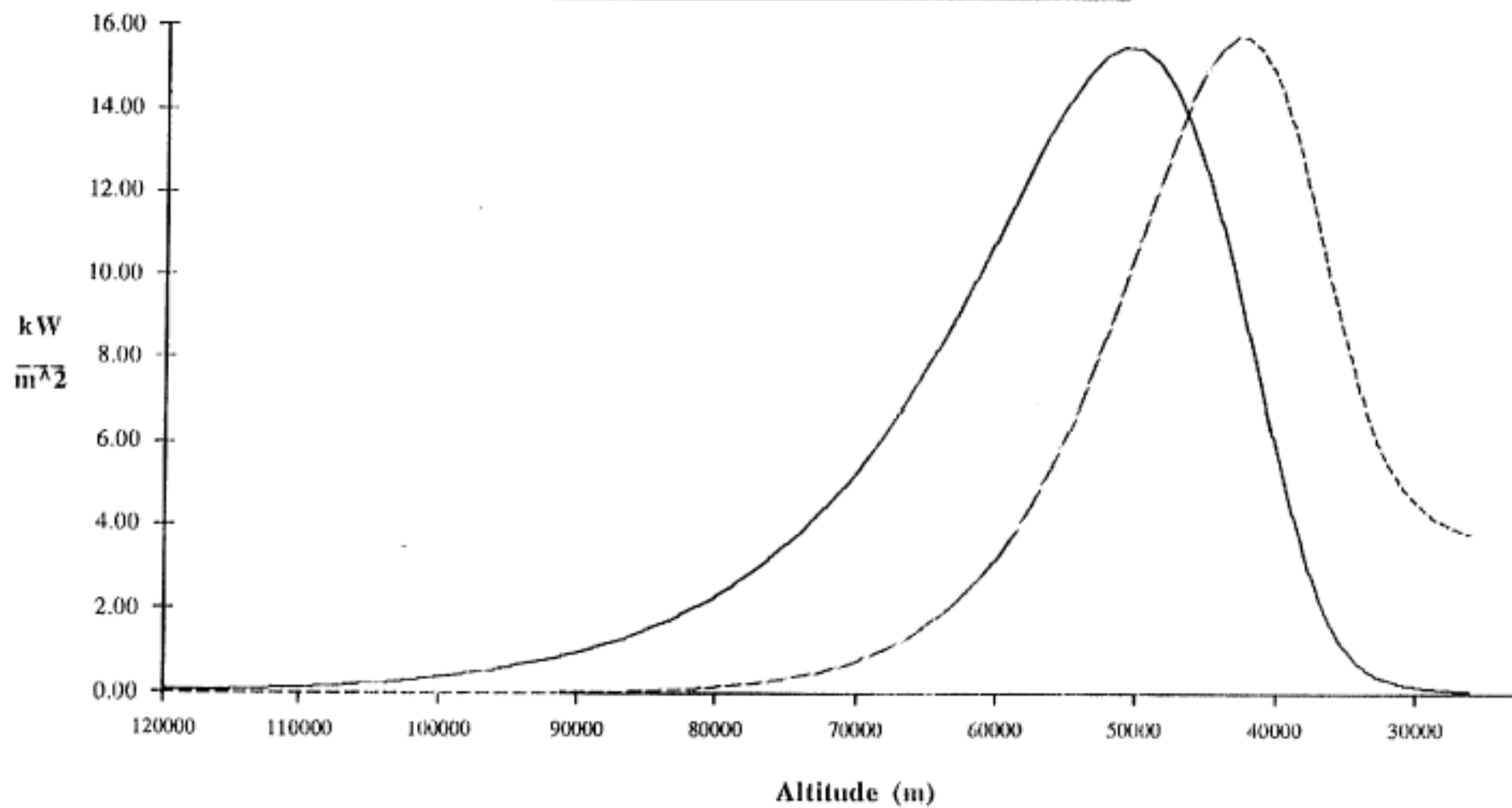

Key Trajectory Parameters

<u>Parameters</u>	<u>Best Case</u>	<u>Worst Case</u>
Roll angle:	0°	180°
Max. temperature:	910° F	913° F
Max. heating rate:	15.4 W/m ²	15.5 W/m ²
Touchdown time (after deployment):	805 sec	795 sec
Downrange distance (after deploy.):	149 km	130 km
Terminal velocity:	23.0 m/sec	23.0 m/sec
Max. dynamic pressure:	1690 Pa	1770 Pa
at Mach:	3.18	3.14
Max. Mach:	5.28	5.28
Max. g's:	7.64	8.00
Total flight duration:	16:19	16:15
Total downrange distance:	229 km (143 mi)	210 km (131 mi)
Apogee:	164 km (102 mi)	164 km (102 mi)

Entry with Total Deployment Failure

Ballistic coefficient:	2150 Pa
Maximum temperature:	2000° F
Maximum deceleration:	9 g
Maximum dynamic pressure:	20,000 Pa
Terminal velocity:	75 m/sec
Prognosis:	poor

Landing Loads

Acceptable Condition: Heat shield shredded

Bent struts

Intact capsule

Terminal Velocity ~23 m/sec (51 mph)

**For water penetration of 3 m,
average deceleration is 9 g**

Nominal Landing Footprint

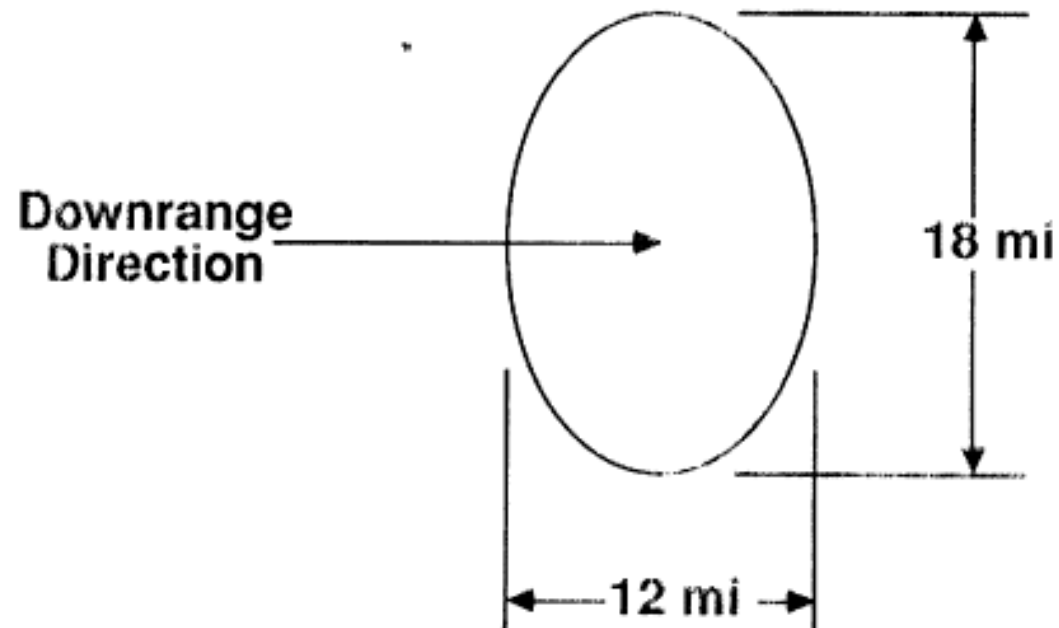

Maximum likelihood landing is at periphery of footprint

Nominal search area of 170 sq. mi.

ParaShield Structure

Strut Structural Design

Radial Strut: 303 Stainless Steel

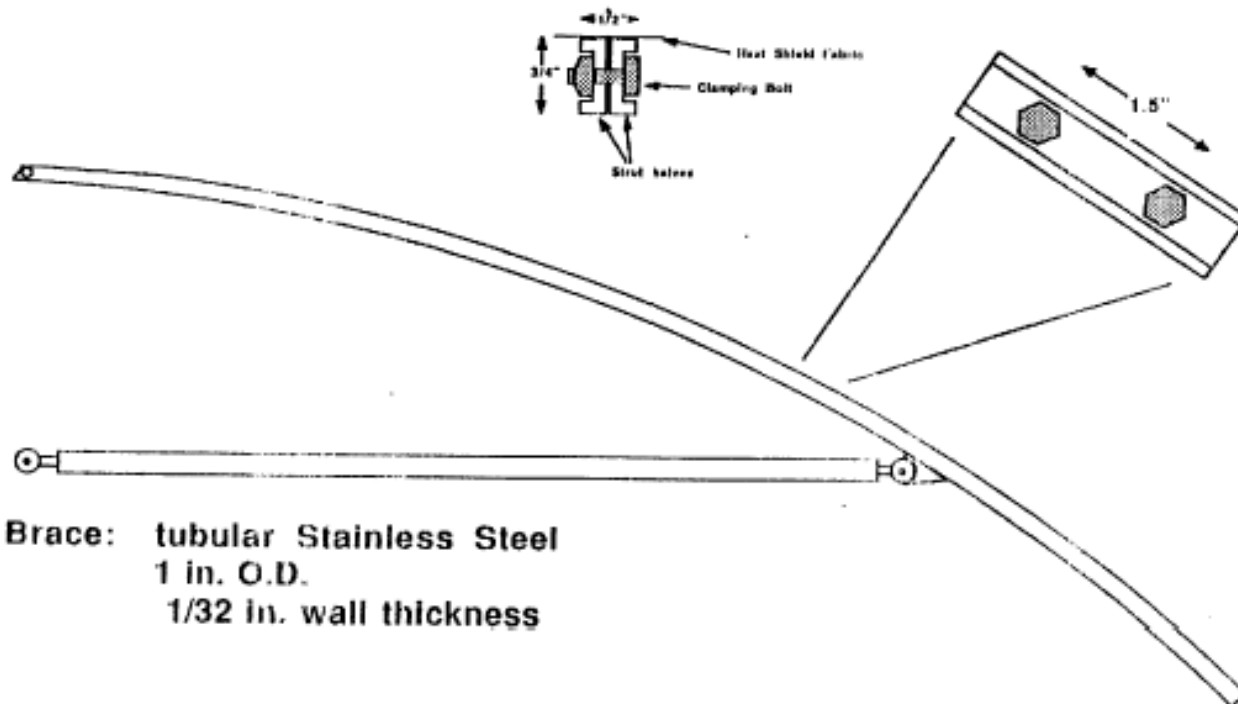

Brace: tubular Stainless Steel
1 in. O.D.
1/32 in. wall thickness

Maximum Stresses, roll angle 180°:

Brace Compression: 915 lbf./strut Buckling limit: 1930 lbf./strut
Radial Strut Bending Stress: 21000 psi Yield strength: 35000 psi

Stress: Radial Strut #7

— Lower Face of Strut — Upper Face of Strut

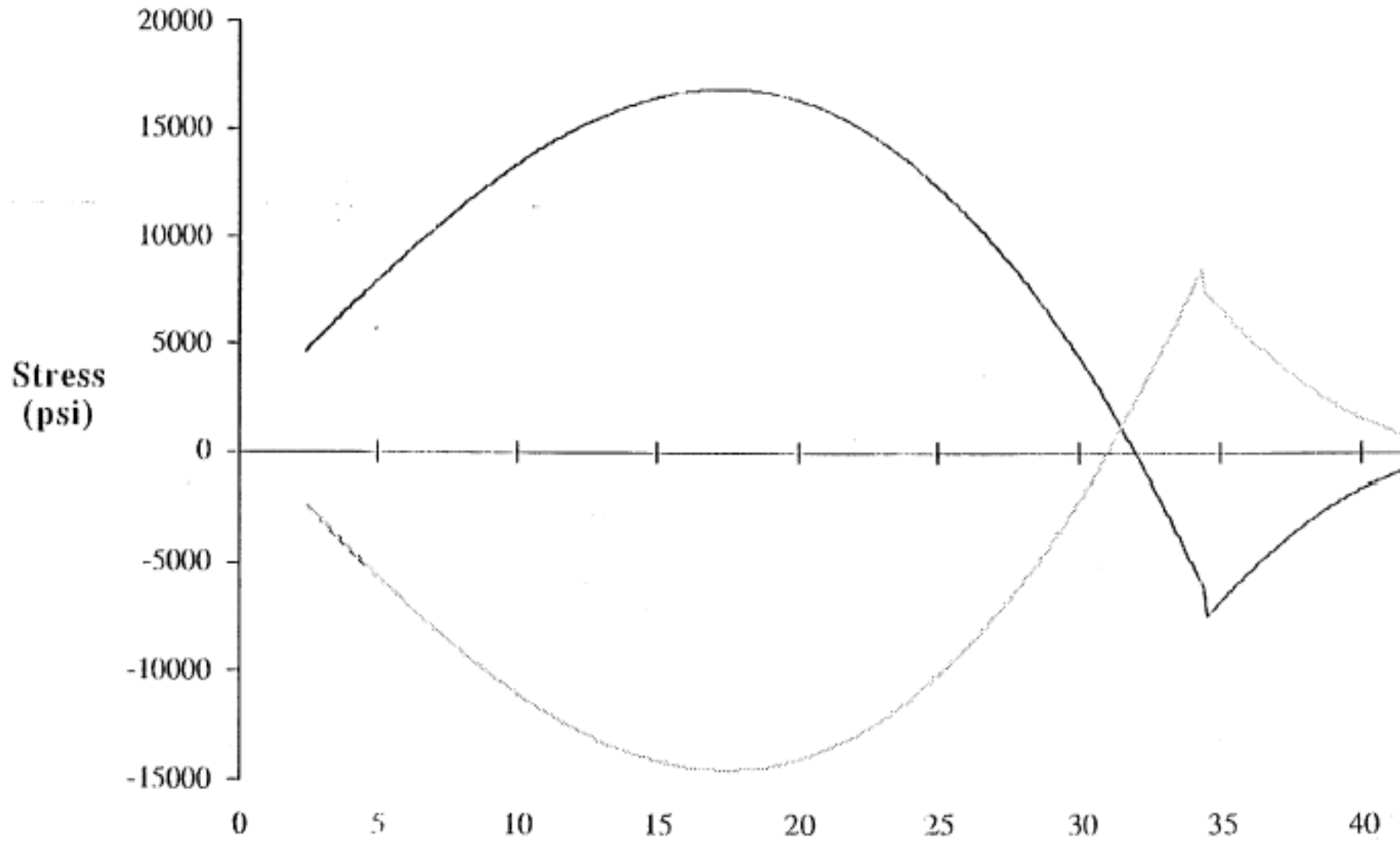

Attitude Control

Thrust vs. Time
(2 X 1/16" throat diameter thrusters, unregulated)

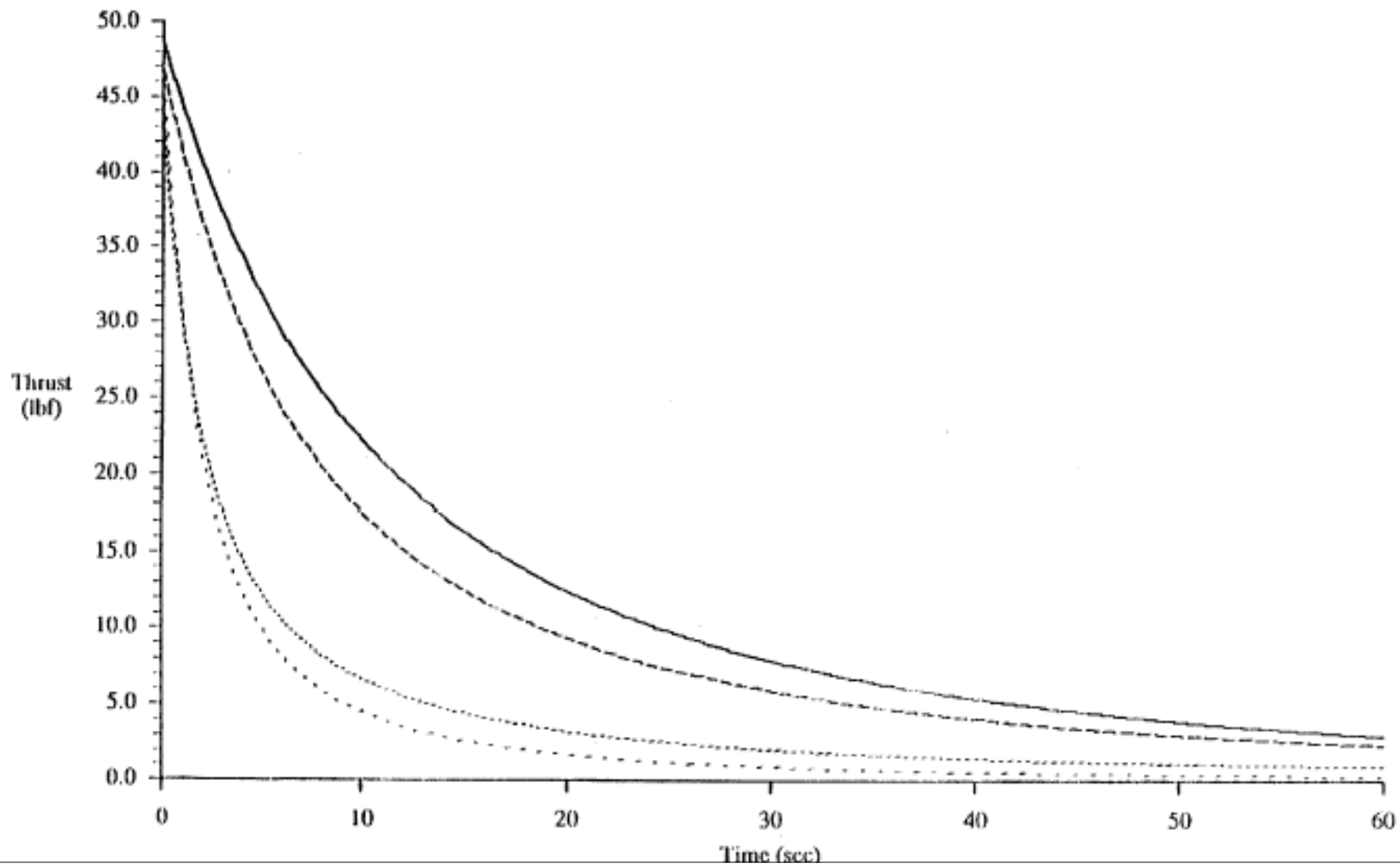

Attitude Control Propulsion

- **Requirements**

- Damping 10 lbf-sec per axis
- Position control 20 lbf-sec per axis
- Total impulse requirement 90 lbf-sec

- **Assumptions**

- Initial tank pressure 4500 psi, regulated to 125 psi
- Tank volume 514 cu.in.
- 2 thrusters, 0.156 in throat diameter

- **Parametric Propellant Analysis**

<u>Propellant</u>	<u>Thrust (lbf)</u>	<u>Impulse (lbf-sec)</u>
Hydrogen	8.15	89.6
Helium	7.65	93.6
Nitrogen	8.15	334.8
CO2	8.44	485.9

T + 245 sec., Mach 3.93, Q = 1.1 Pa
Initial Tumble Rate: 360°/sec.
Damping Control Only

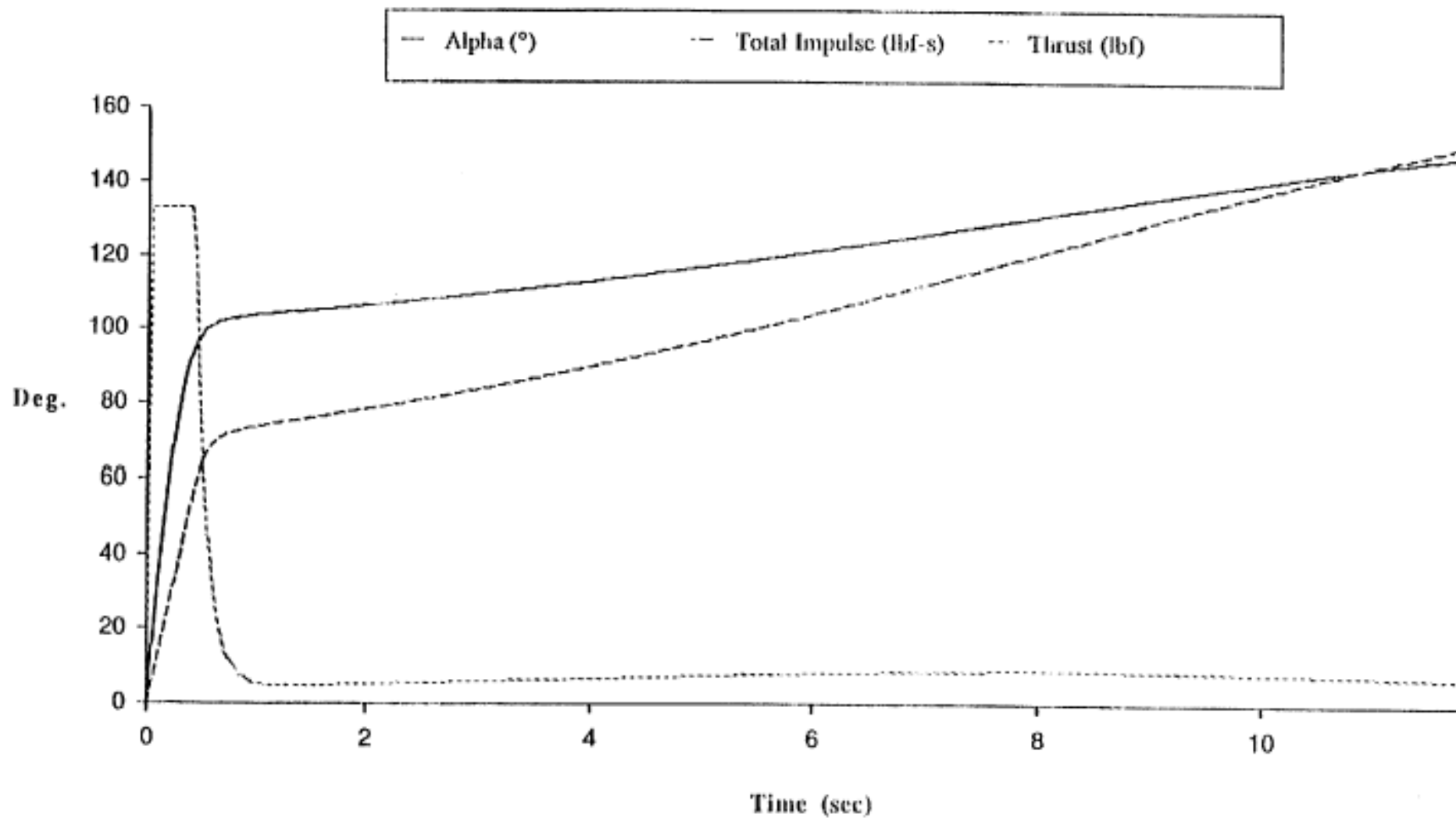

T + 361 sec., Mach 5.28, Q = 19.7 Pa

--- Alpha (°) - - - Total Impulse (lbf-s) ··· Thrust (lbf)

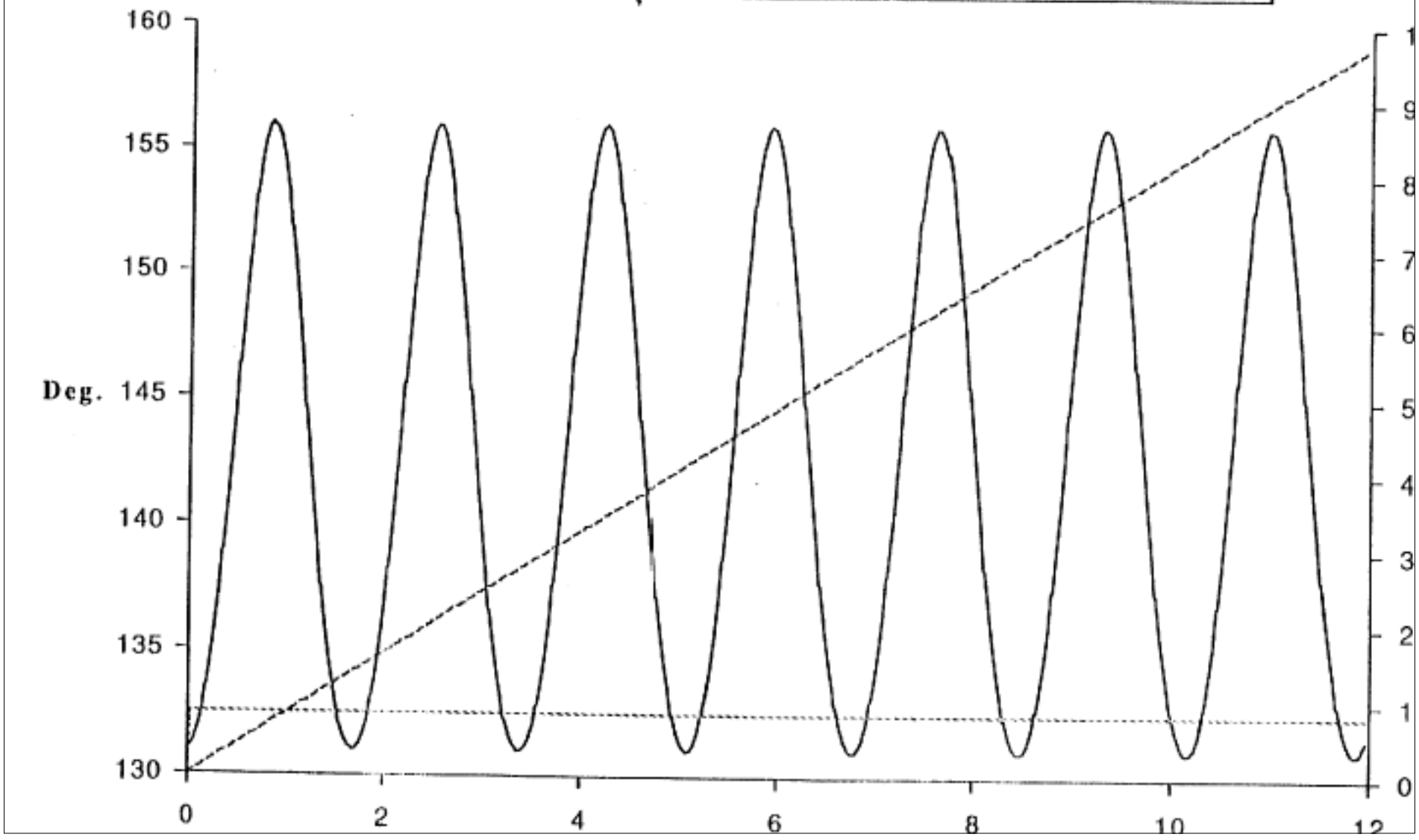

T + 969 sec., Mach .07, Q = 391.4 Pa

— Alpha (°) - - - Total Impulse (lbf-s) ···· Thrust (lbf)

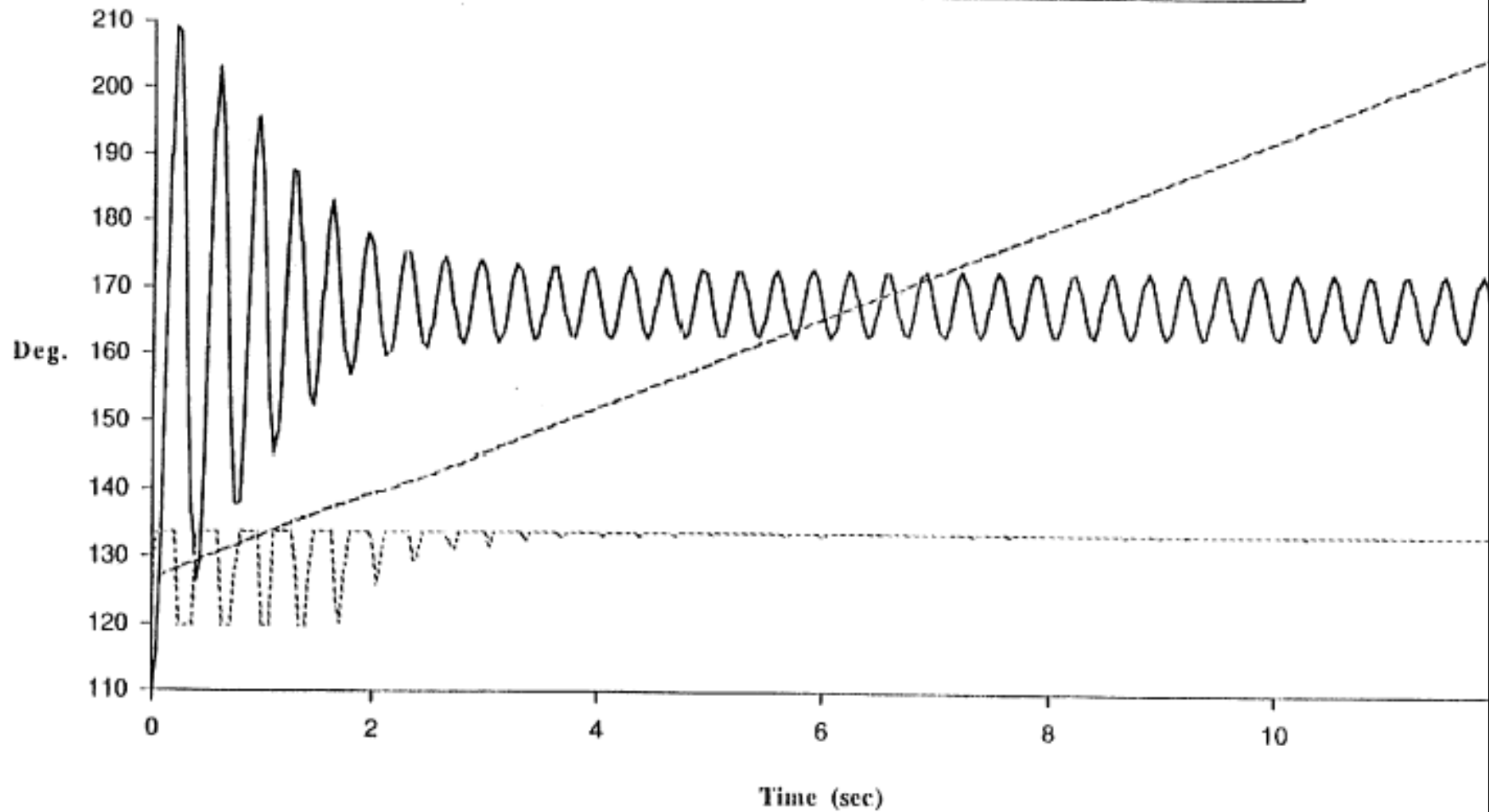

Avionics

Flight Timeline

<u>Time</u>	<u>Event</u>
T – 15 min	Power up internal systems; pressurize thruster manifold
T – 120 sec	Start video camera
T – 0 sec	Launch; start master event timer; start data recording
T + 80 sec	Thrust termination
T + 144 sec	Jettison payload shroud
T + 159 sec	Detach vehicle from booster; engage attitude rate damping; start SLR camera; start mechanical deployment timer; arm ParaShield deployment
T + 174 sec	Begin nominal deployment of ParaShield
T + 184 sec	Nominal deployment of ParaShield completed
T + 220 sec	Begin contingency deployment of ParaShield
T + 230 sec	Contingency deployment of ParaShield completed
T + 345 sec	Encounter sensible atmosphere; engage attitude control
T + 370 sec	Disengage attitude control; engage attitude rate damping
T + 975 sec	Deploy recovery beacon

Sensor Complement

- **16 RTD temperature transducers**
 - 12 on ParaShield fabric
 - 3 on capsule exterior
 - 1 in capsule interior
- **4 strain gauge bridges**
 - Strain on radial and brace struts
- **4 accelerometers**
- **3 fluidic rate sensors**
- **5 pressure transducers**
 - Static pressure
 - Dynamic pressure
 - Capsule environment
 - Low pressure manifold
 - High pressure manifold

Control Electronics

- **Primary Control and Data Computer**
 - Ampro 80286 single-board (AT clone)
 - Coded in C and Assembler
 - Program stored in EPROM
 - Data recorded in EAROM
 - Total data capacity 128Kx8
- **Distributed Redundant Data Computers**
 - F86HC11 microcontroller boards
 - Coded in Forth
 - Program and data stored in nonvolatile SRAM
 - Total data capacity 16Kx8 each
- **Master Event Timer**
 - Master reference clock bused to all processors
 - Synchronized interrupt for data collection, main flight control
- **Contingency Deployment Controller**
 - 60 sec mechanical timer initiated at separation

Interfaces to Booster

Interface Plate Specifics

- **Three to four pairs of ball-lock mechanism and guide pin assemblies--enough to support transverse loading and lateral vibrations during launch sequence**
- **Guide pins prevent rotation and assist in mating of payload to interface plate on launch pad**
- **Ball-lock and pin assemblies mate to outer flange of back plate of recovery module**
- **Interface plate has space in middle for camera lenses and beacon assembly**
- **Space is left around thrusters to ensure clean separation of payload from booster**

Payload Interface Plate

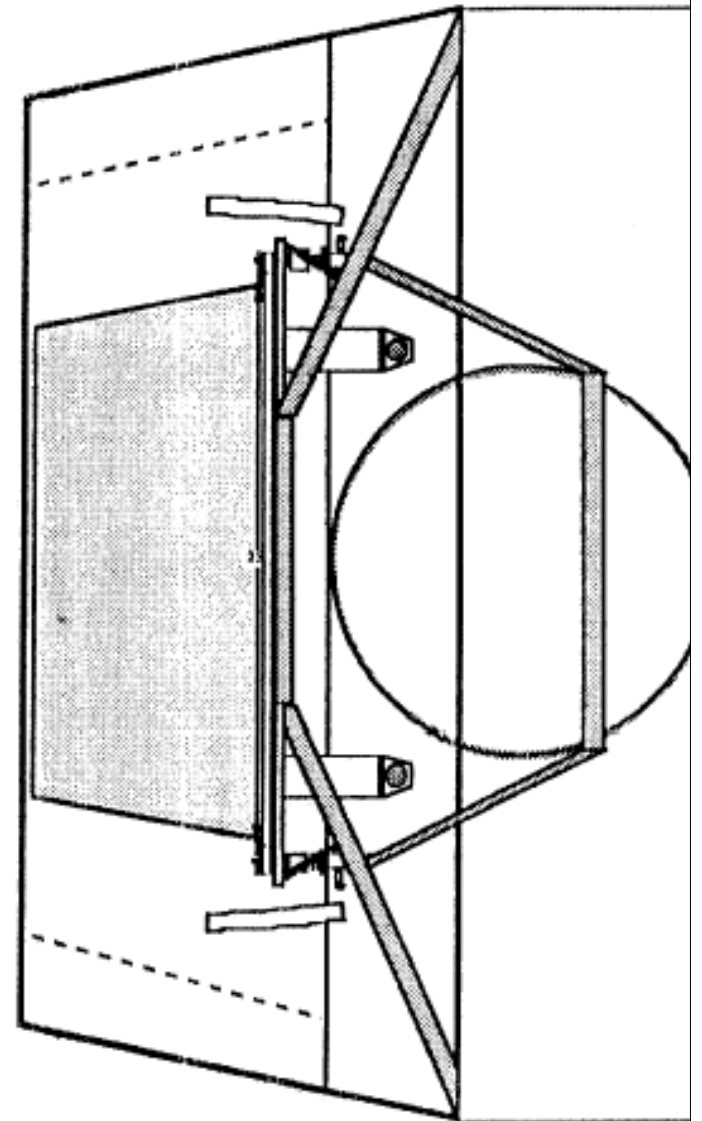
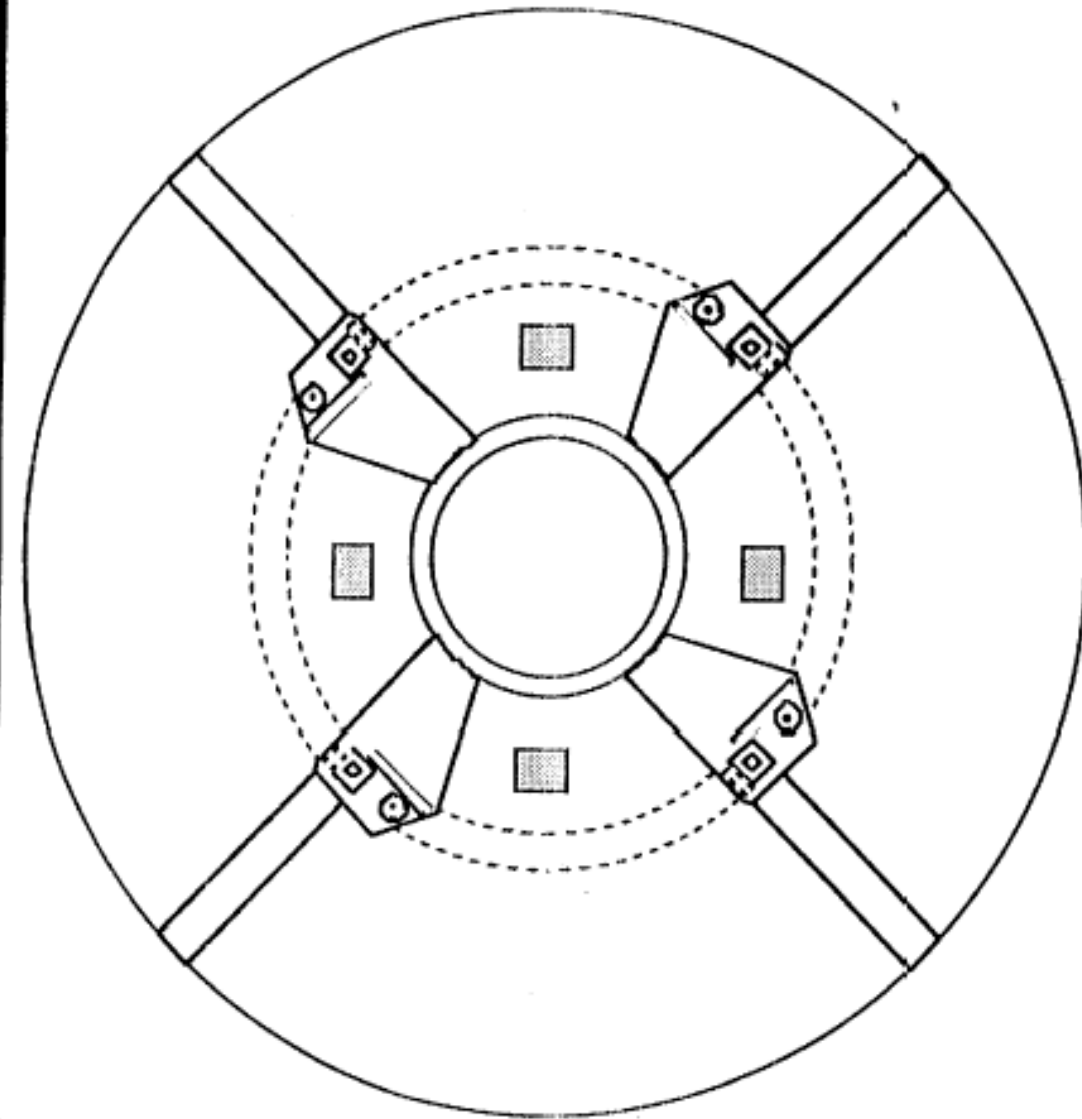

Summary

Payload Integration

Payload arrives July 1, 1989

Acceptance check: verify post-shipping integrity and repair if necessary

Functional check

- **Fit check to payload interface plate--done previously at MIT if possible**
- **Verify operation of all systems**

Booster mating

- **Lift payload to top of booster--guidelines necessary to protect payload from support structure**
- **Engage ball-lock mechanisms and make electrical connections**
- **Remove lifting assembly--will need support scaffolding**
- **Attach front protective plate**

System monitoring until launch

Remaining Design Tasks

- **Structural Dynamics**
- **Power Distribution System**
- **Data and Control System**
- **Optimal Control Algorithm**
- **Heat Transfer**
- **Low-Speed Aerodynamics**
- **Internal Layout**

Planned/Potential Testing

- **Systems Testing**
 - **Lab Bench**
 - **Integration (in lab)**
 - **Acceptance (at pad)**

- **Vacuum Chamber**
 - **Deployment Mechanism**
 - **Control System (single-axis)**
 - **Capsule Thermal Environment**
 - **End-to-end Mission Simulation**

- **Low-Speed Aerodynamics**
 - **Stability at Terminal Velocity**
 - **Water Impact Test**

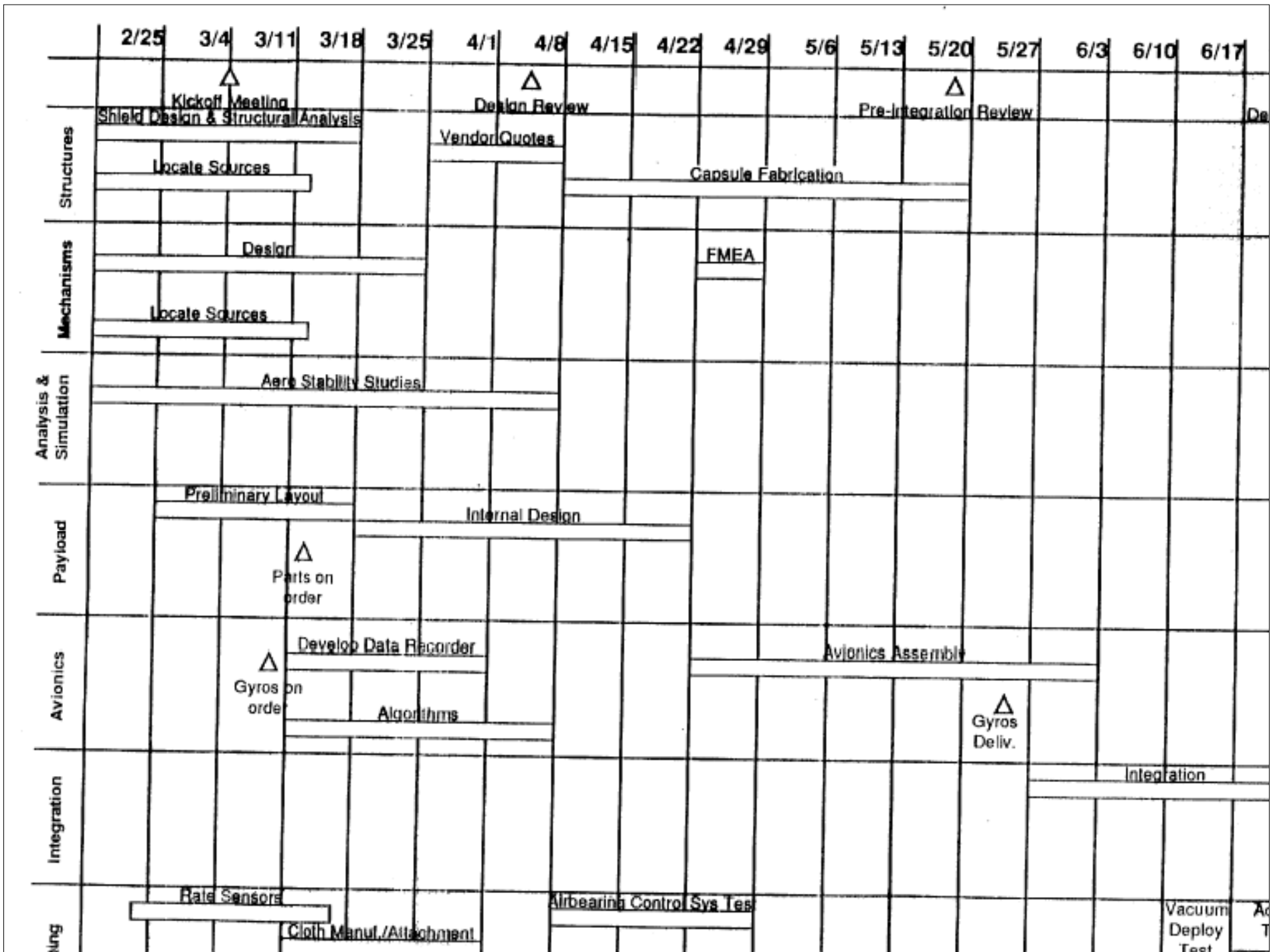

Summary

- **Designs and analyses complete enough to begin general procurement and fabrication**
- **Detailed analyses indicate ParaShield concept will meet or exceed original performance expectations**
- **Resolution of primary interface issues (mechanical and electrical) expected from this trip**
- **Major remaining concerns are operational details, such as visual acquisition of capsule following splashdown**
- **Program on track to support launch window beginning 20 July 1989**

Early Assembly of Shield Structure

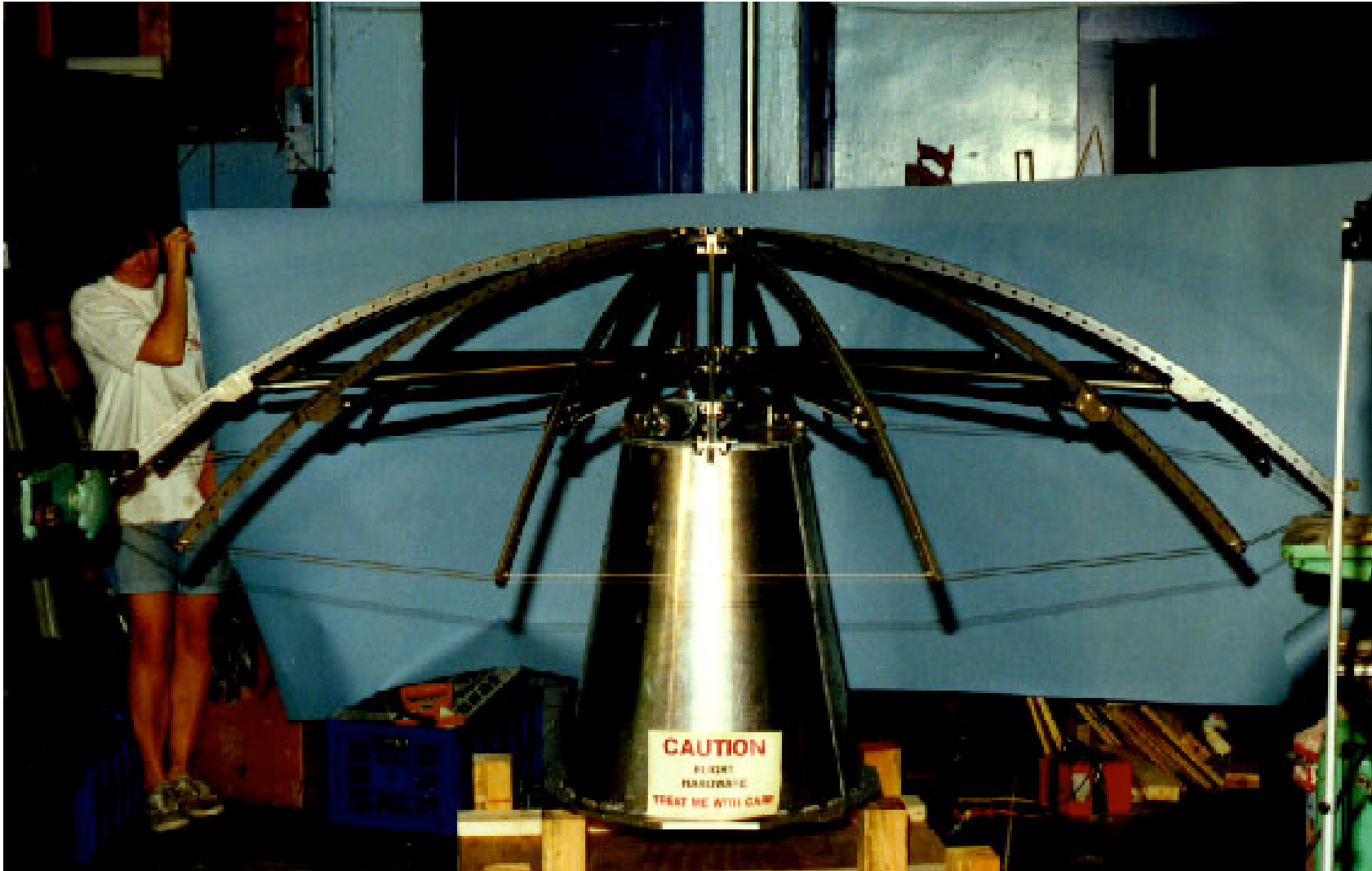

UNIVERSITY OF
MARYLAND

Case Study: ParaShield and Skidbladnir
Principles of Space Systems Design

The Skidbladnir Development Team



UNIVERSITY OF
MARYLAND

Case Study: ParaShield and Skidbladnir
Principles of Space Systems Design

Shield Structure and Deployment

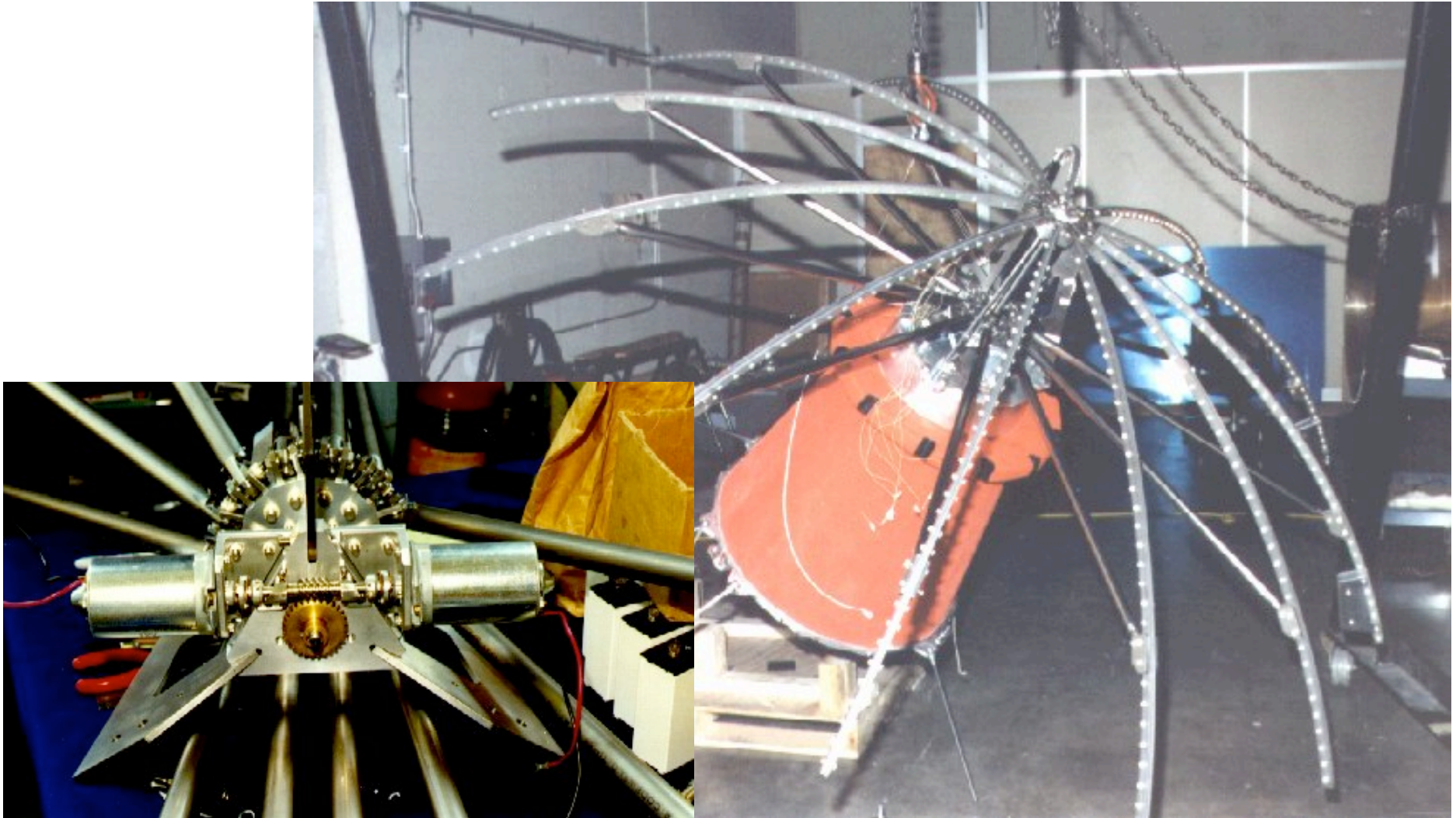

UNIVERSITY OF
MARYLAND

Case Study: ParaShield and Skidbladnir
Principles of Space Systems Design

ParaShield Stowed and Deployed



UNIVERSITY OF
MARYLAND

Case Study: ParaShield and Skidbladnir
Principles of Space Systems Design

Launch Vehicle Integration

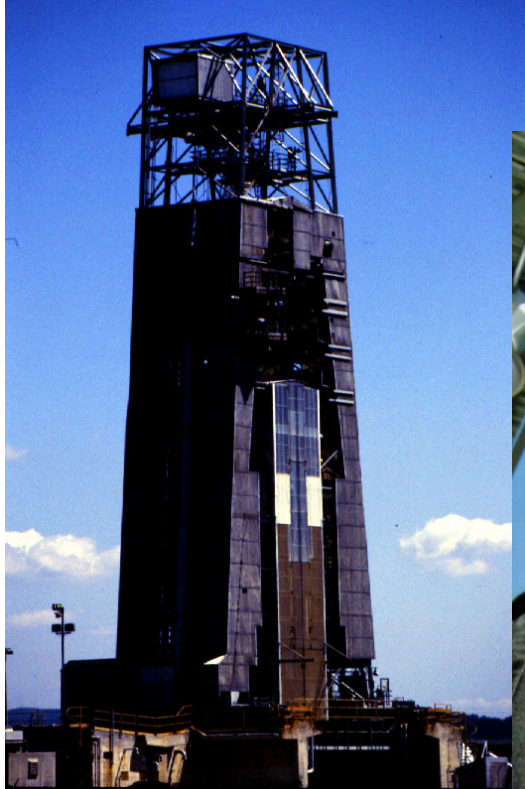

UNIVERSITY OF
MARYLAND

Case Study: ParaShield and Skidbladnir
Principles of Space Systems Design

October 5, 1989 - T+2 sec



UNIVERSITY OF
MARYLAND

Case Study: ParaShield and Skidbladnir
Principles of Space Systems Design

October 5, 1989 - T+60 sec



UNIVERSITY OF
MARYLAND

Case Study: ParaShield and Skidbladnir
Principles of Space Systems Design

October 6, 1989 - Aftermath



UNIVERSITY OF
MARYLAND

Case Study: ParaShield and Skidbladnir
Principles of Space Systems Design