

Ground Processing and Launch Facilities

- Historical examples: Saturn I and V
- Modern example: Delta IV Heavy

Saturn V Launch Facility

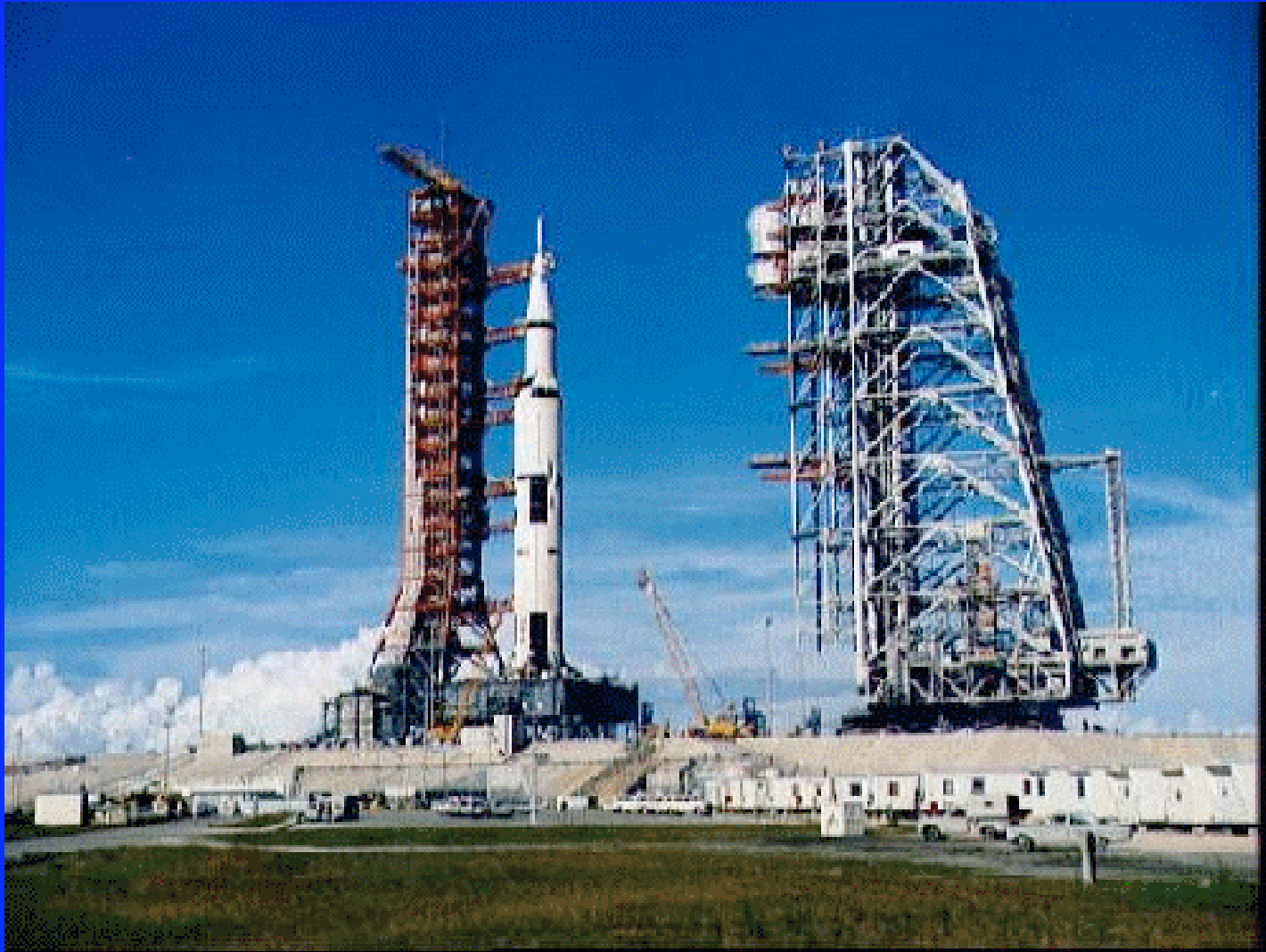

Cape Canaveral circa 1950



Map of Cape Canaveral

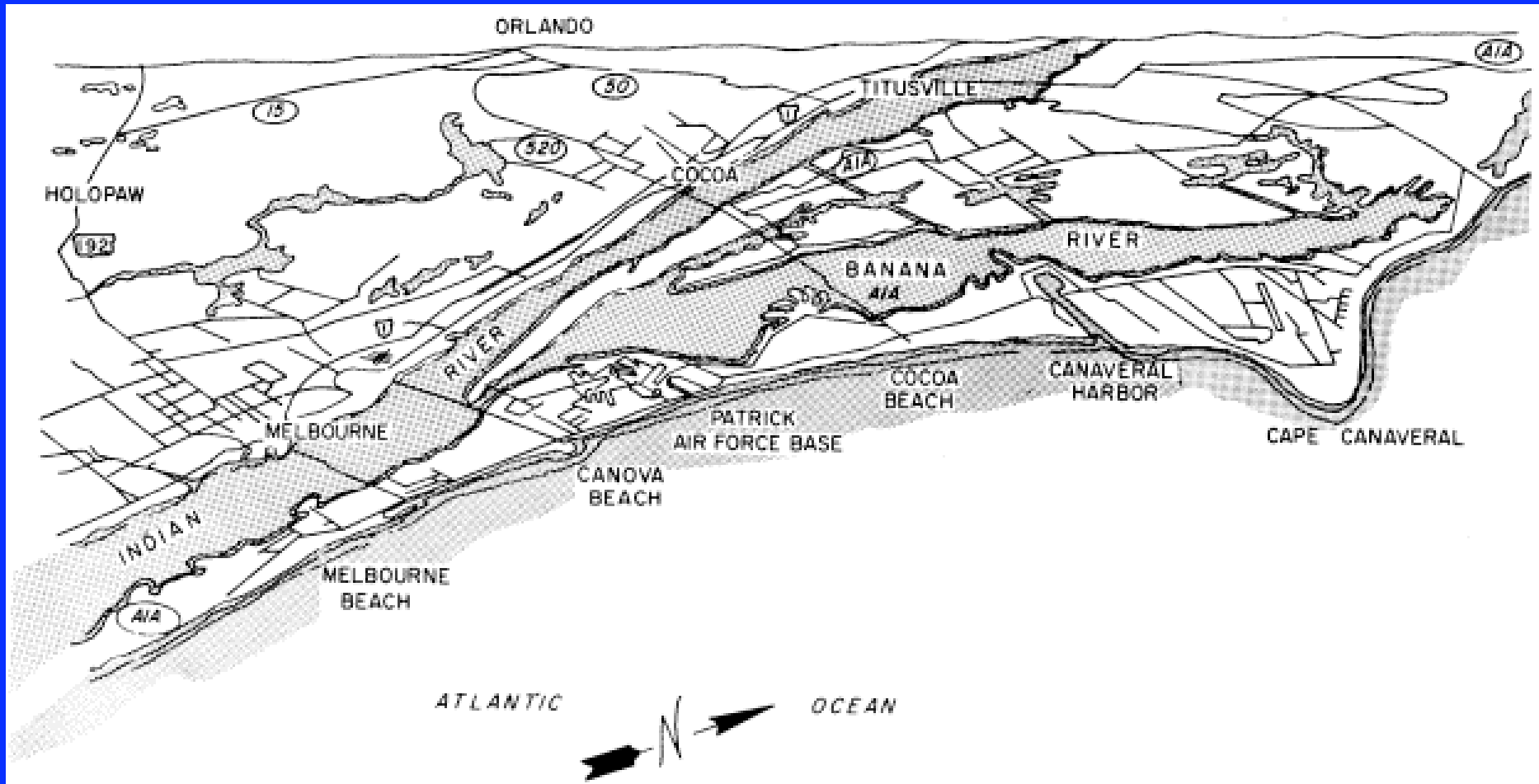

"ICBM Row"



UNIVERSITY OF
MARYLAND

Ground Processing and Launch Facilities
Principles of Space Systems Design

LC-34 Schematic



Saturn I Launch Pedestal

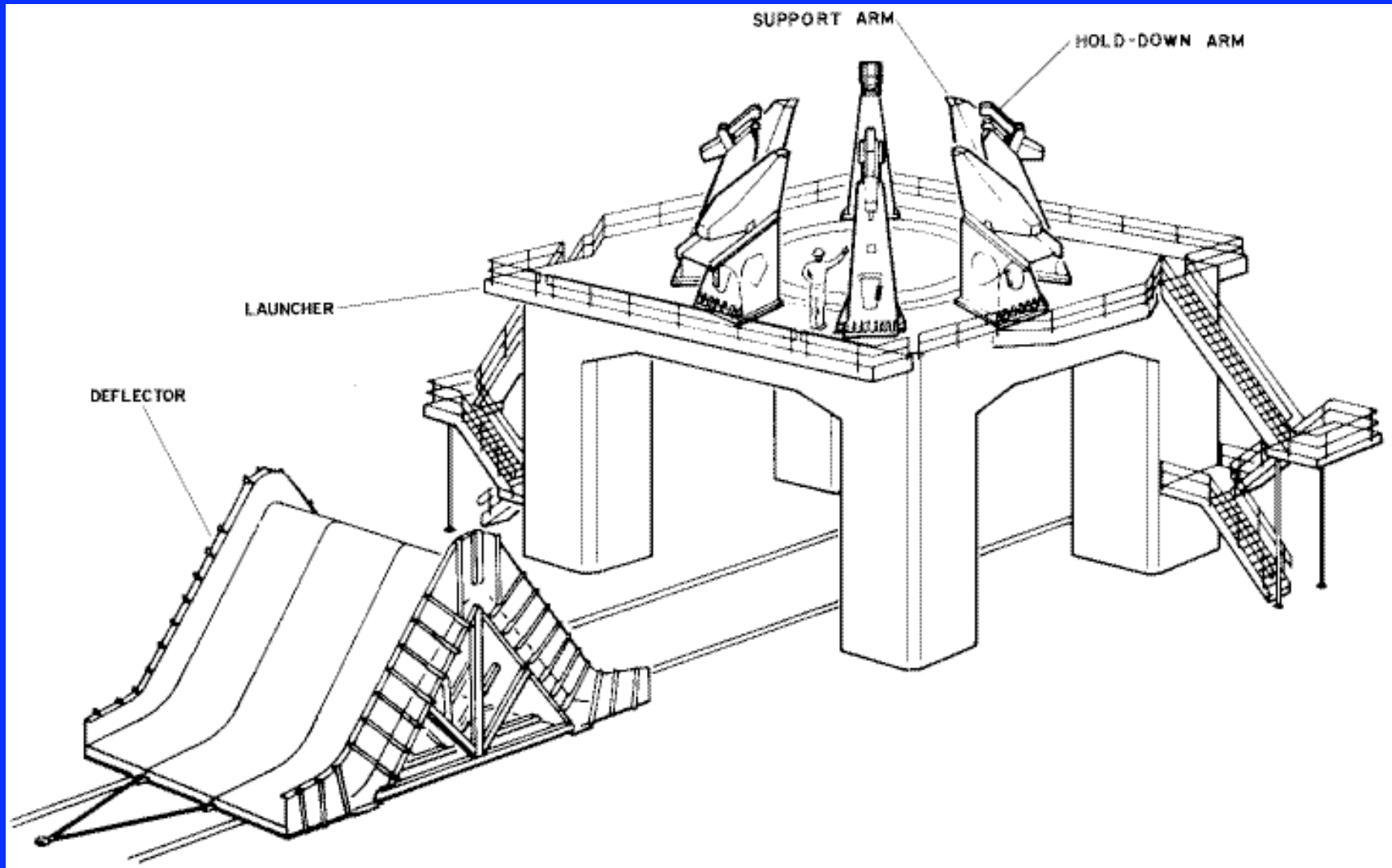

LC-34 Launch Pedestal Under Construction



LC-34 Service Structure

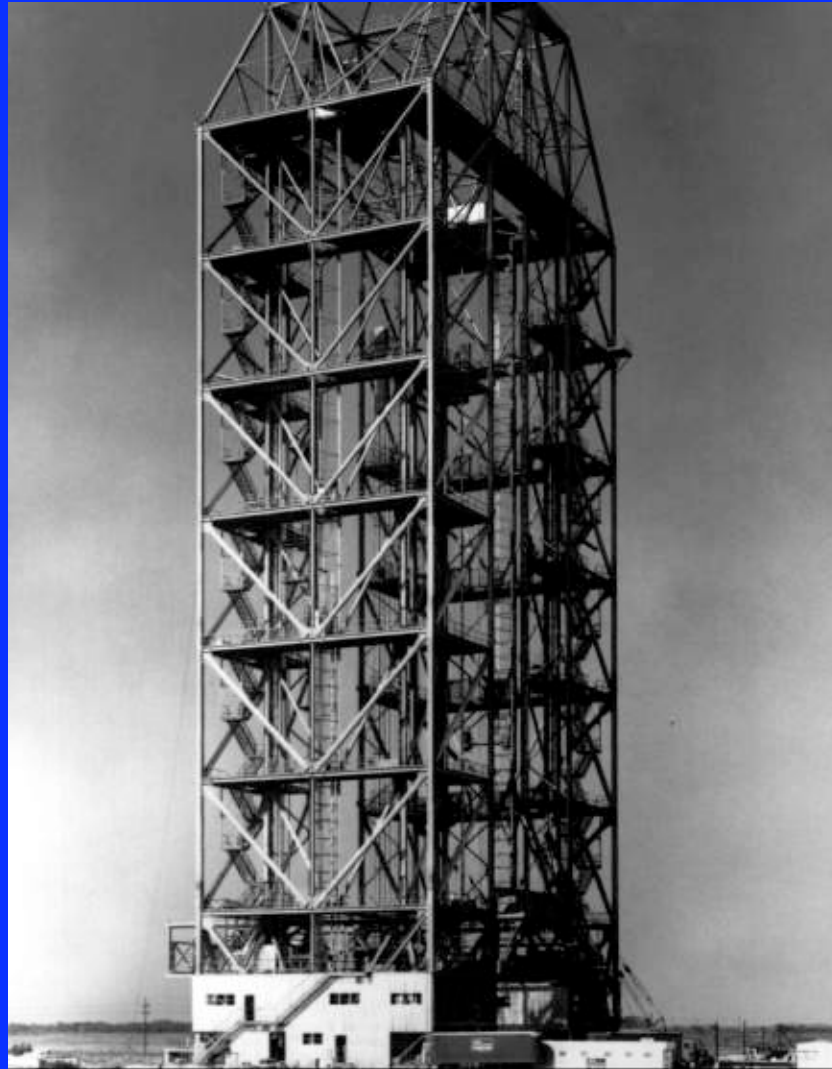

UNIVERSITY OF
MARYLAND

Ground Processing and Launch Facilities
Principles of Space Systems Design

LC-34 Blockhouse



LC-34 Flame Deflector



Aerial View of LC-34



Aerial View of LC-34



Barge Transport of Launch Vehicle Stages

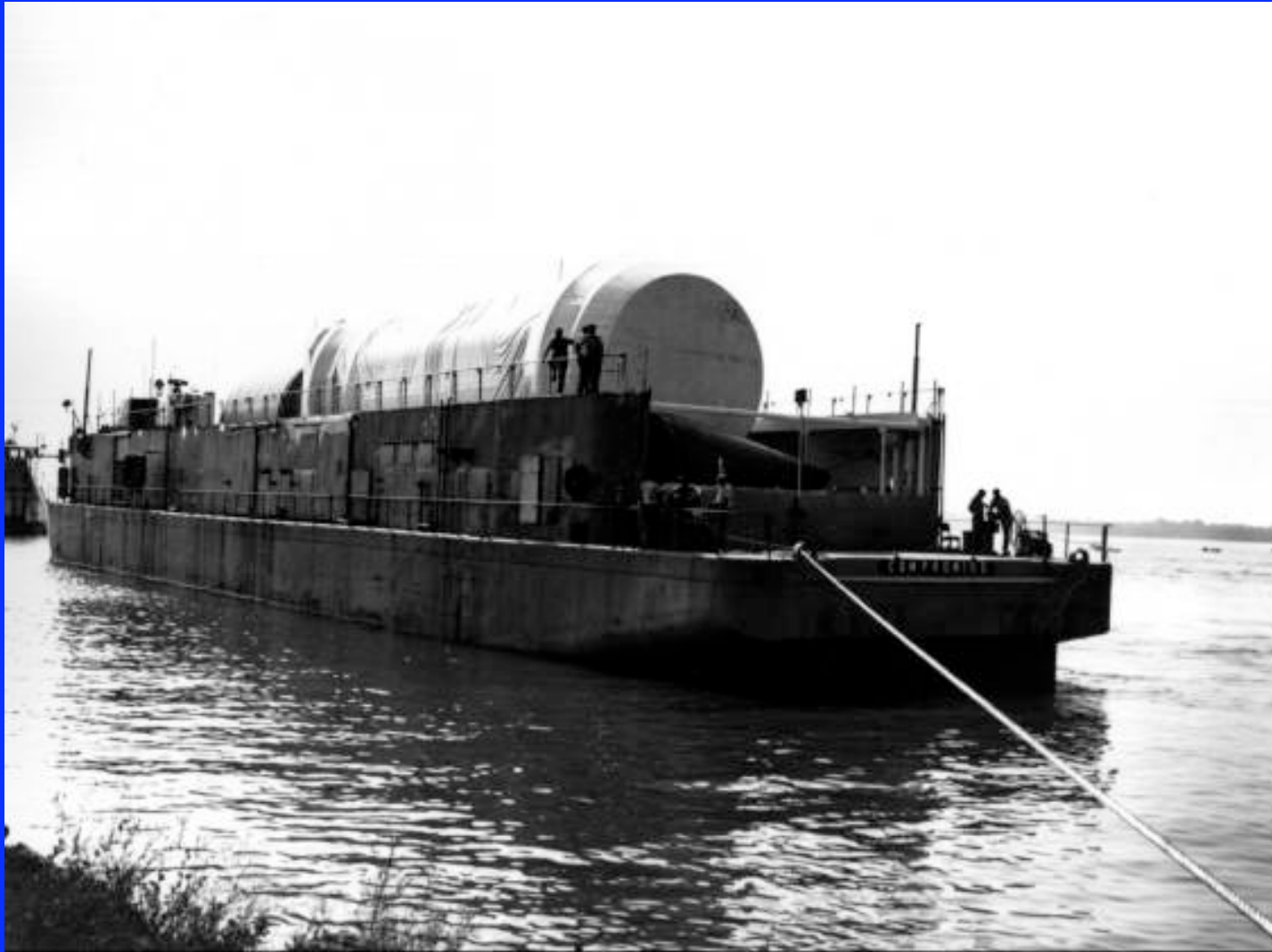

Aerial Transport of Stages



S-I Stage Rotation



S-I Stage Rotation



Saturn I Erection Process

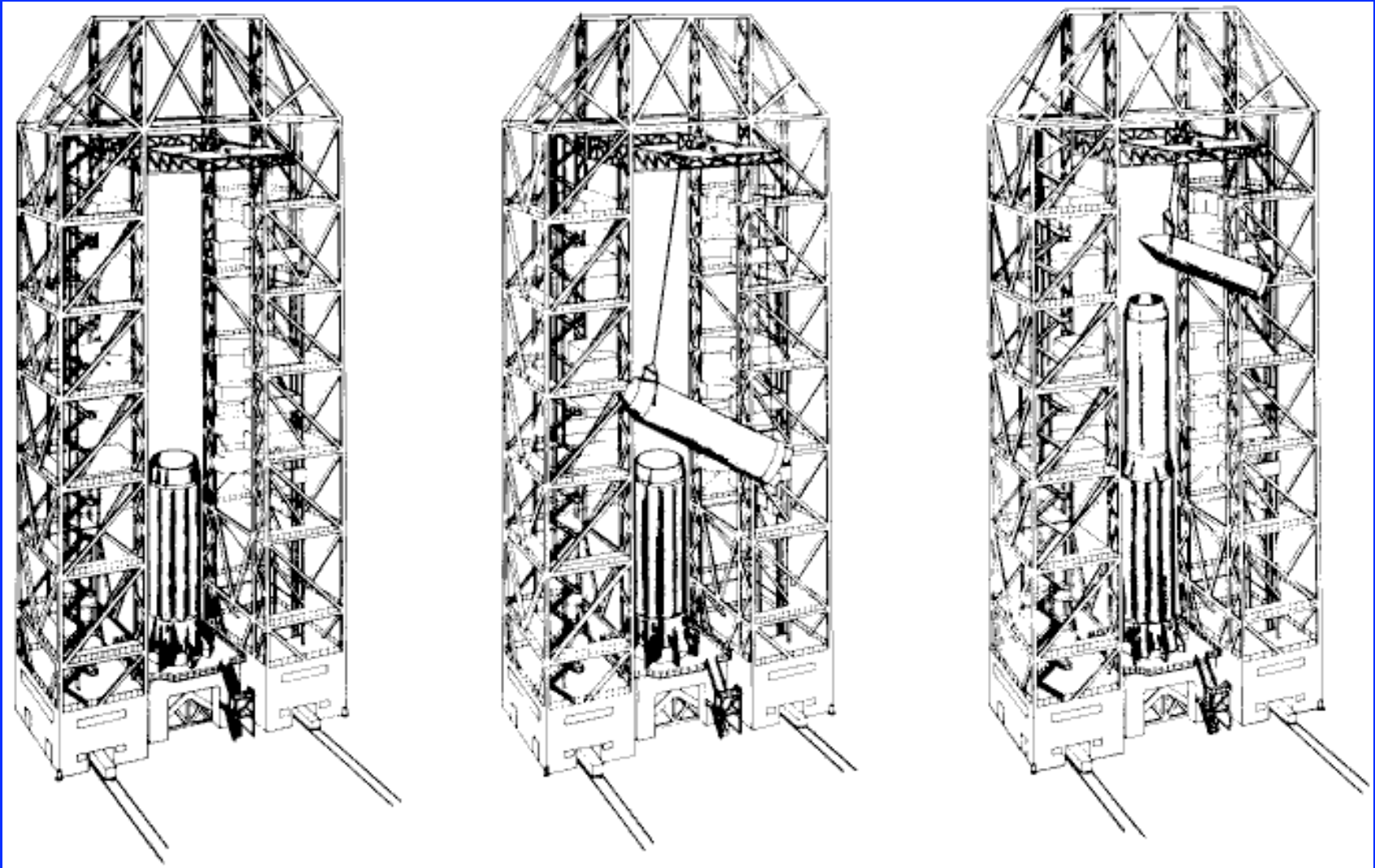

SA-201 Launch

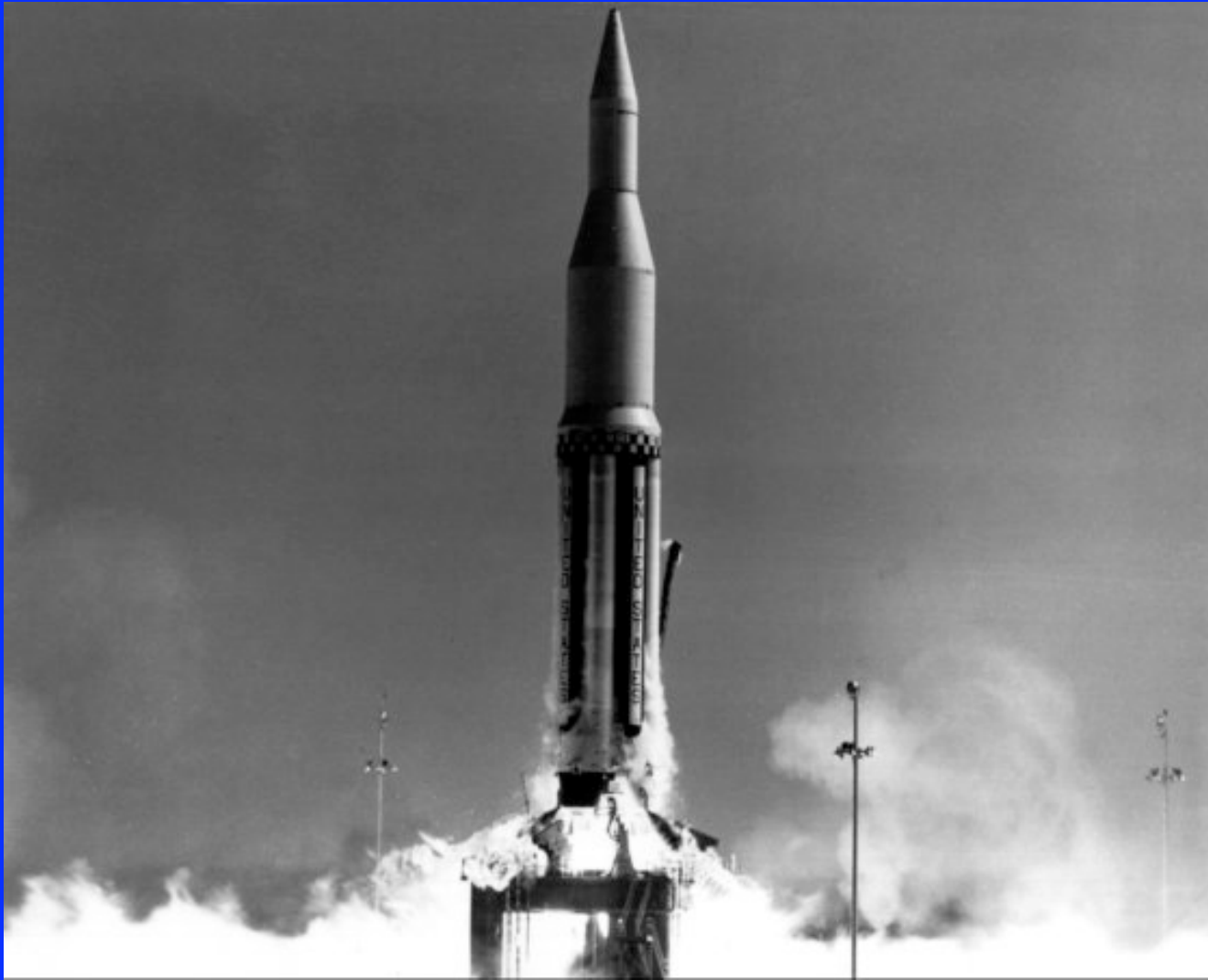

Cape Canaveral Siting Map

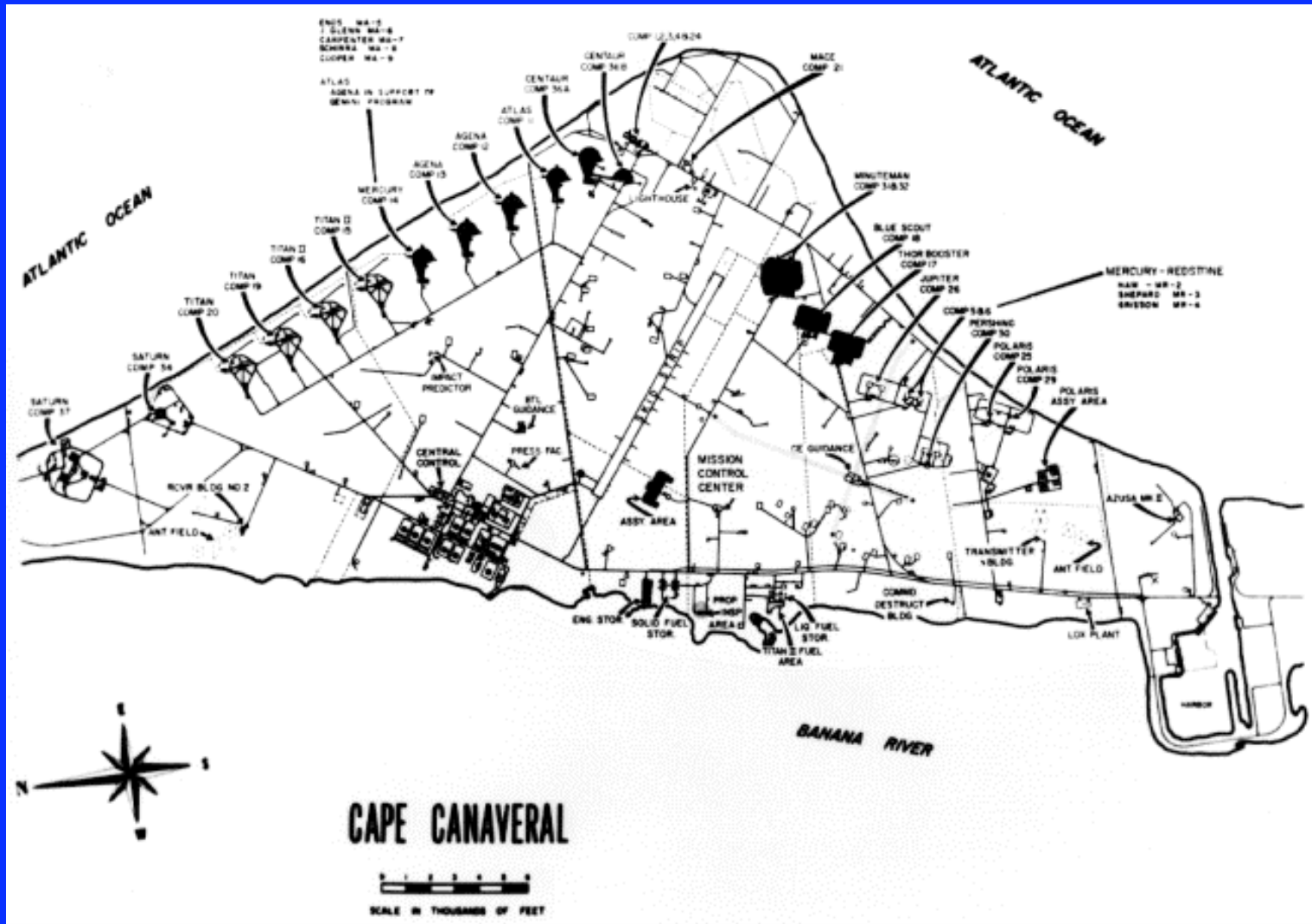

Concept of an Off-Shore Launch Facility

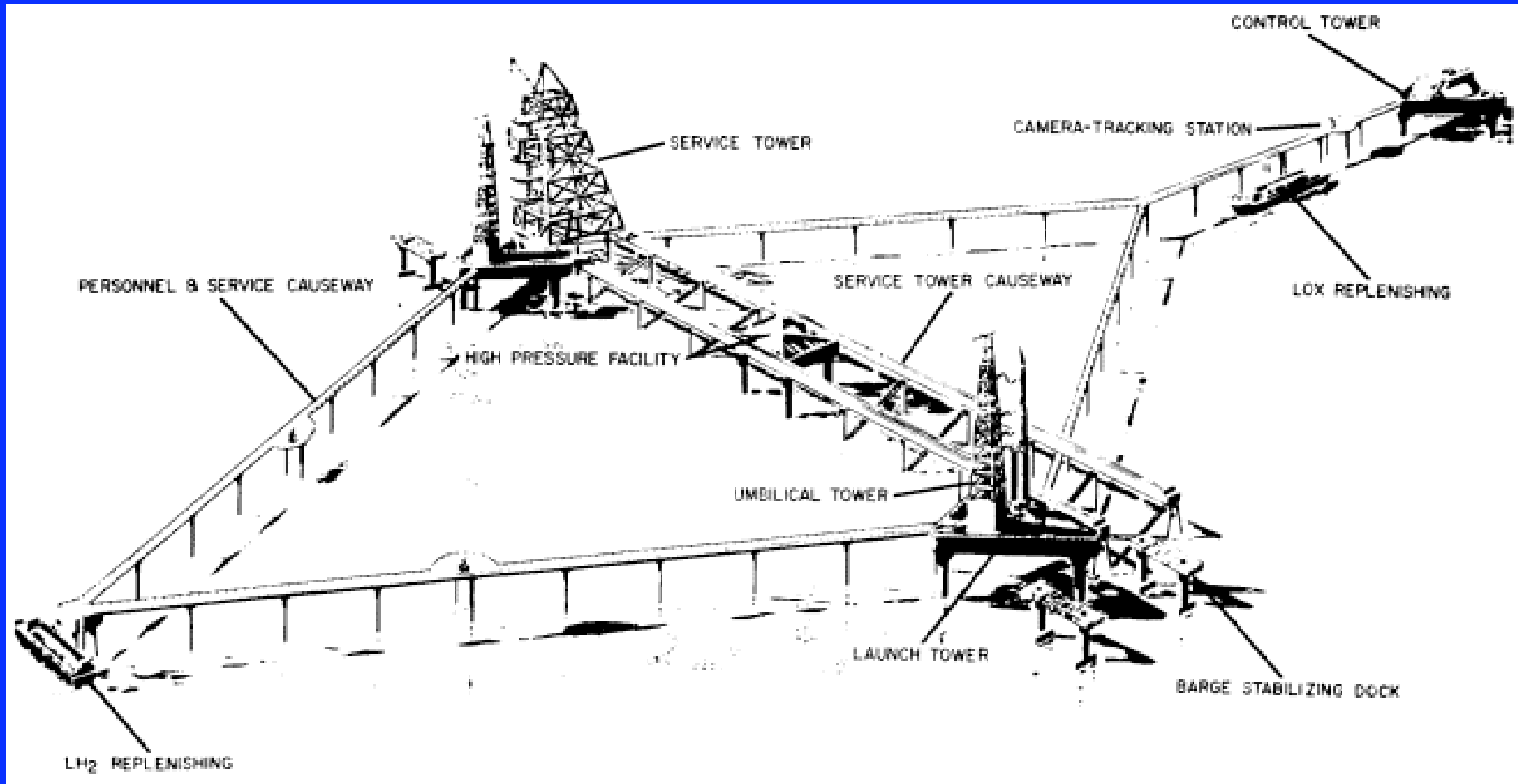

Early Mobile Launch Complex Concept

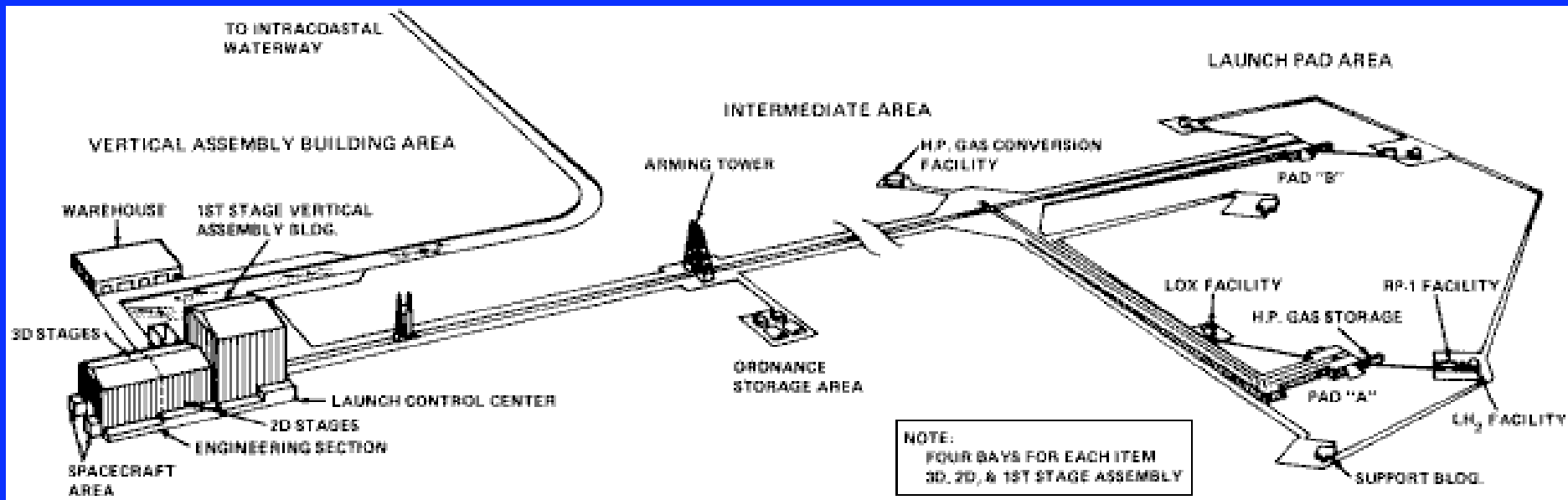

Launch Sites Considered for Apollo

- Cape Canaveral
- Offshore from Cape Canaveral
- Mayaguana Island in the Bahamas
- Cumberland Island, Georgia
- A mainland site near Brownsville, Texas
- White Sands Missile Range in New Mexico
- Christmas Island in the mid-Pacific south of Hawaii
- South Point on the island of Hawaii



Merritt Island Launch Area (MILA)

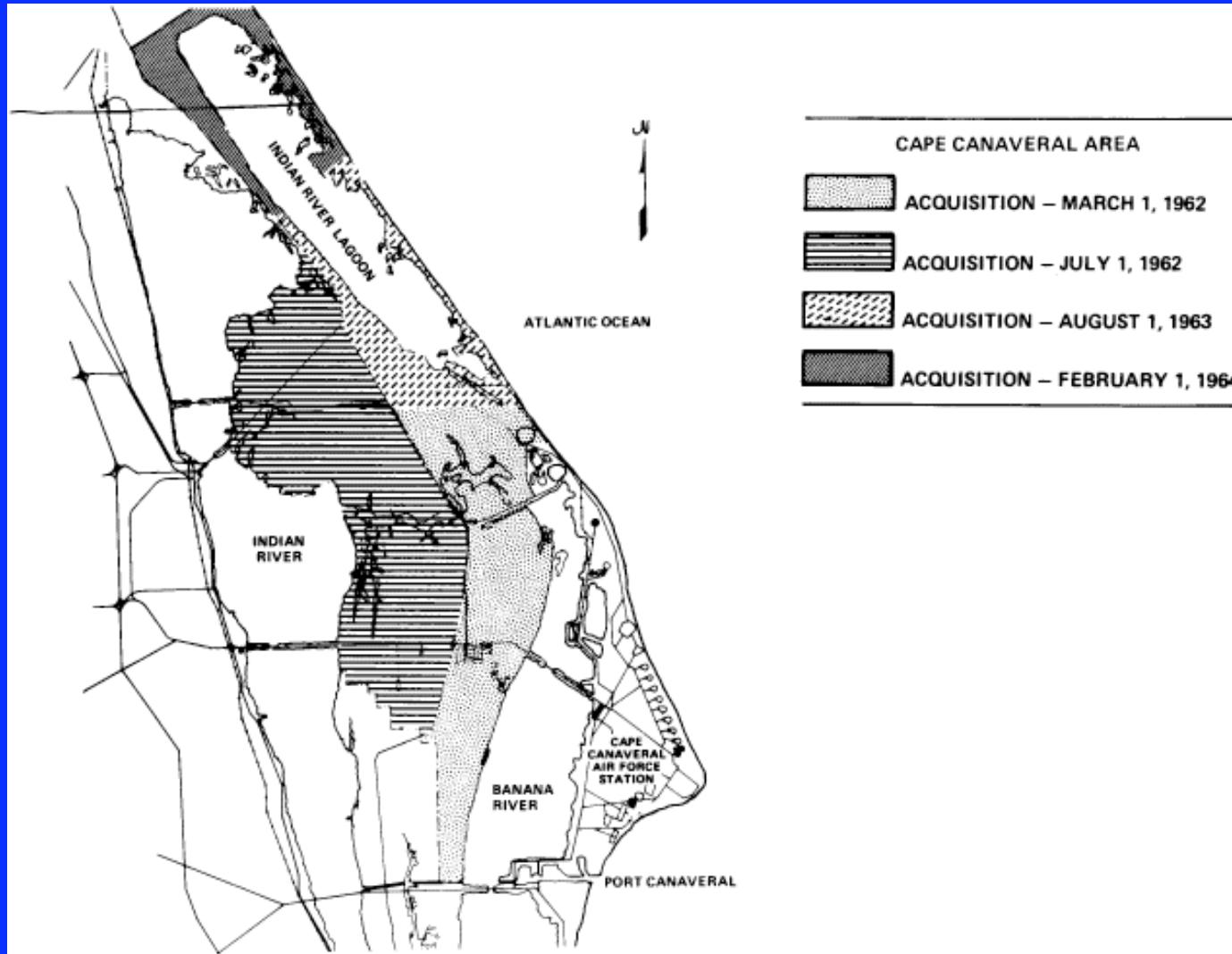

Competition for MILA Launch Sites

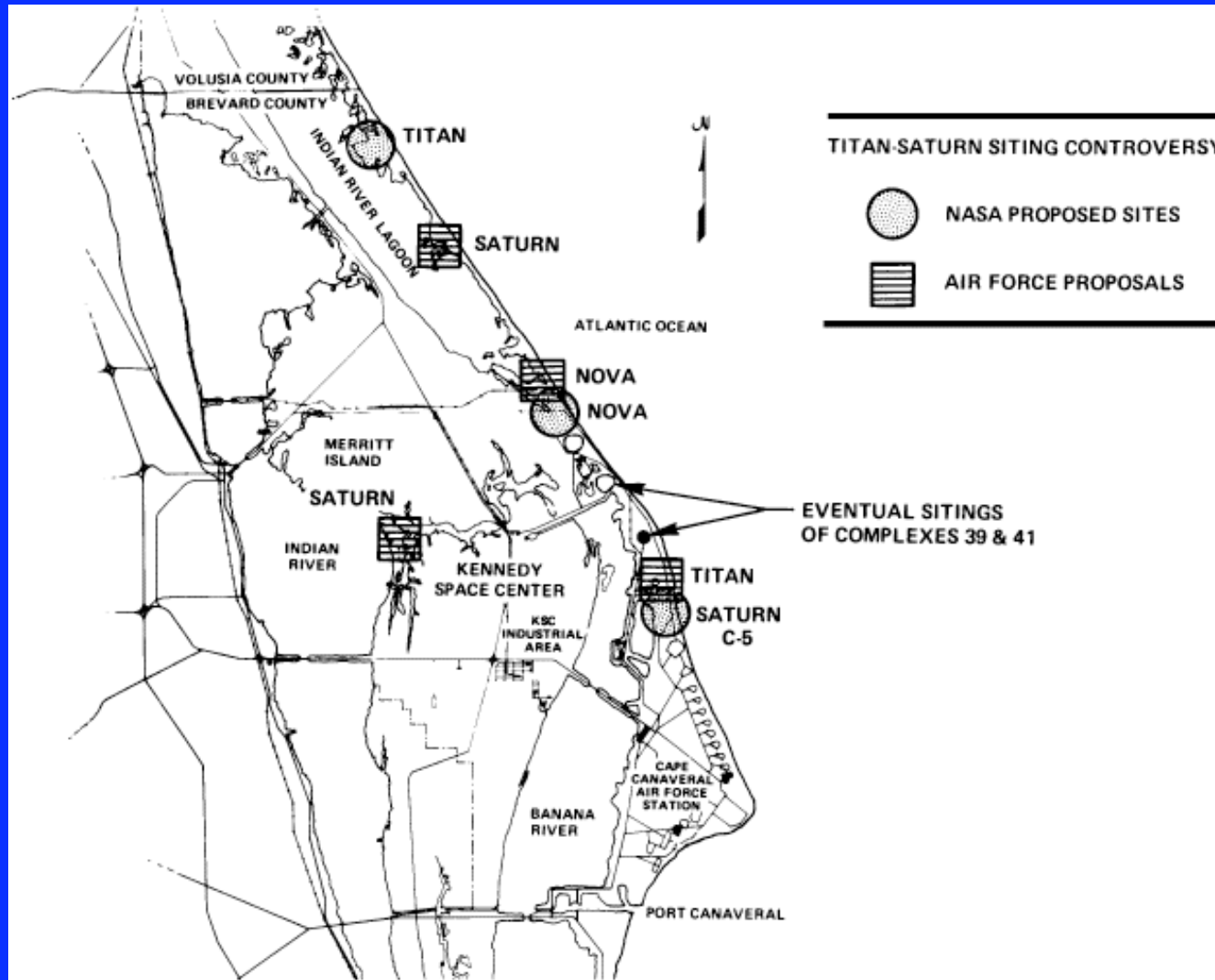

Rail-Based Nova Launch Concept

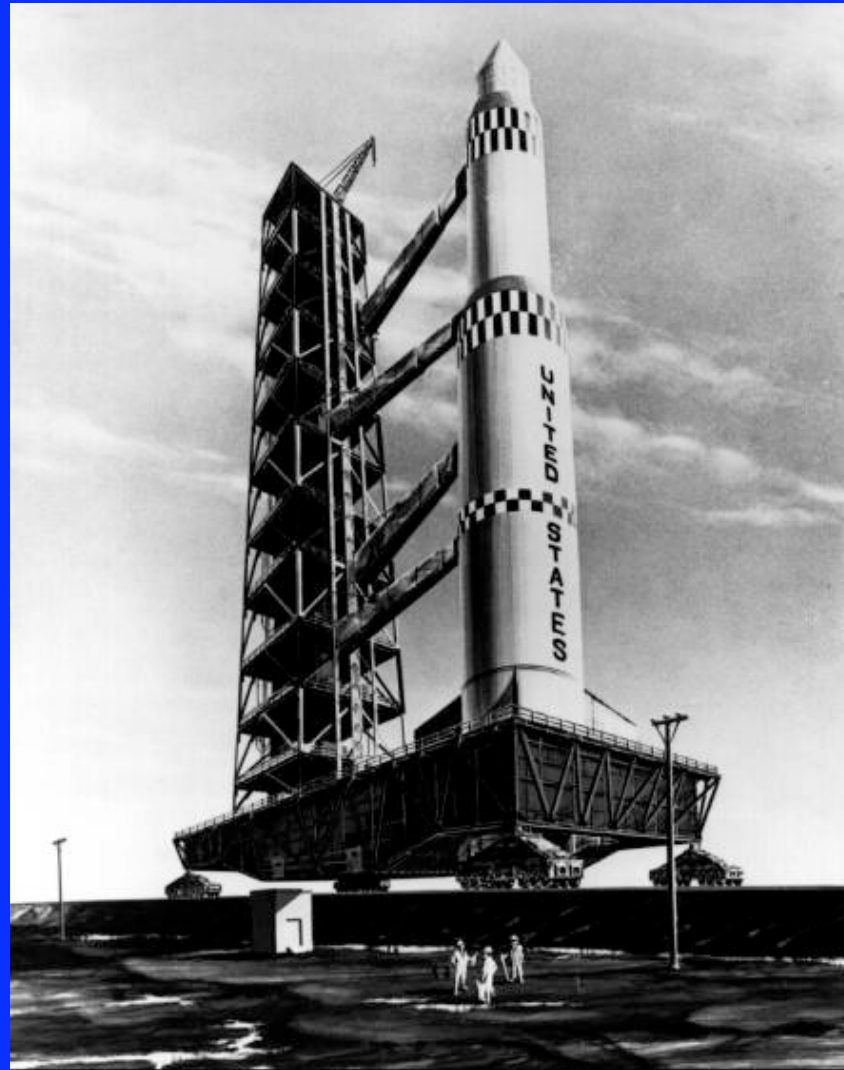

Barge-Based Saturn V Launch Concept

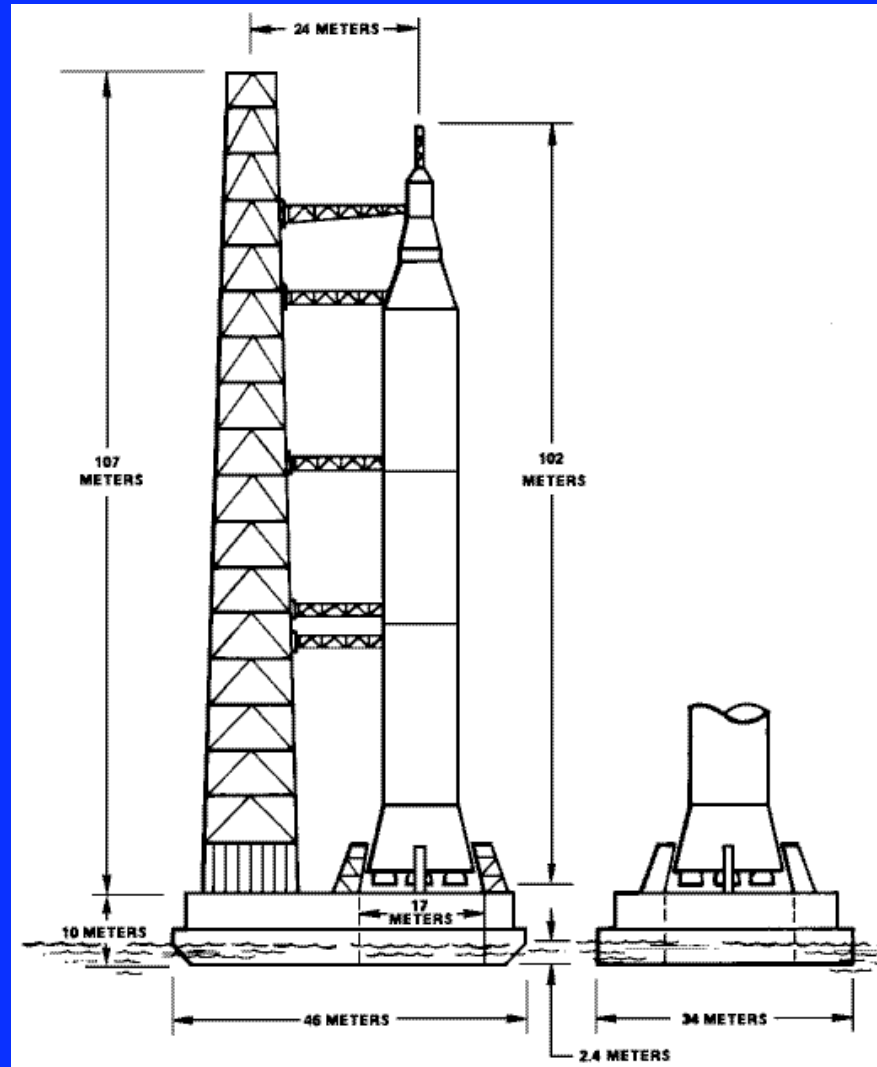

Barge-Based Vertical Assembly Building

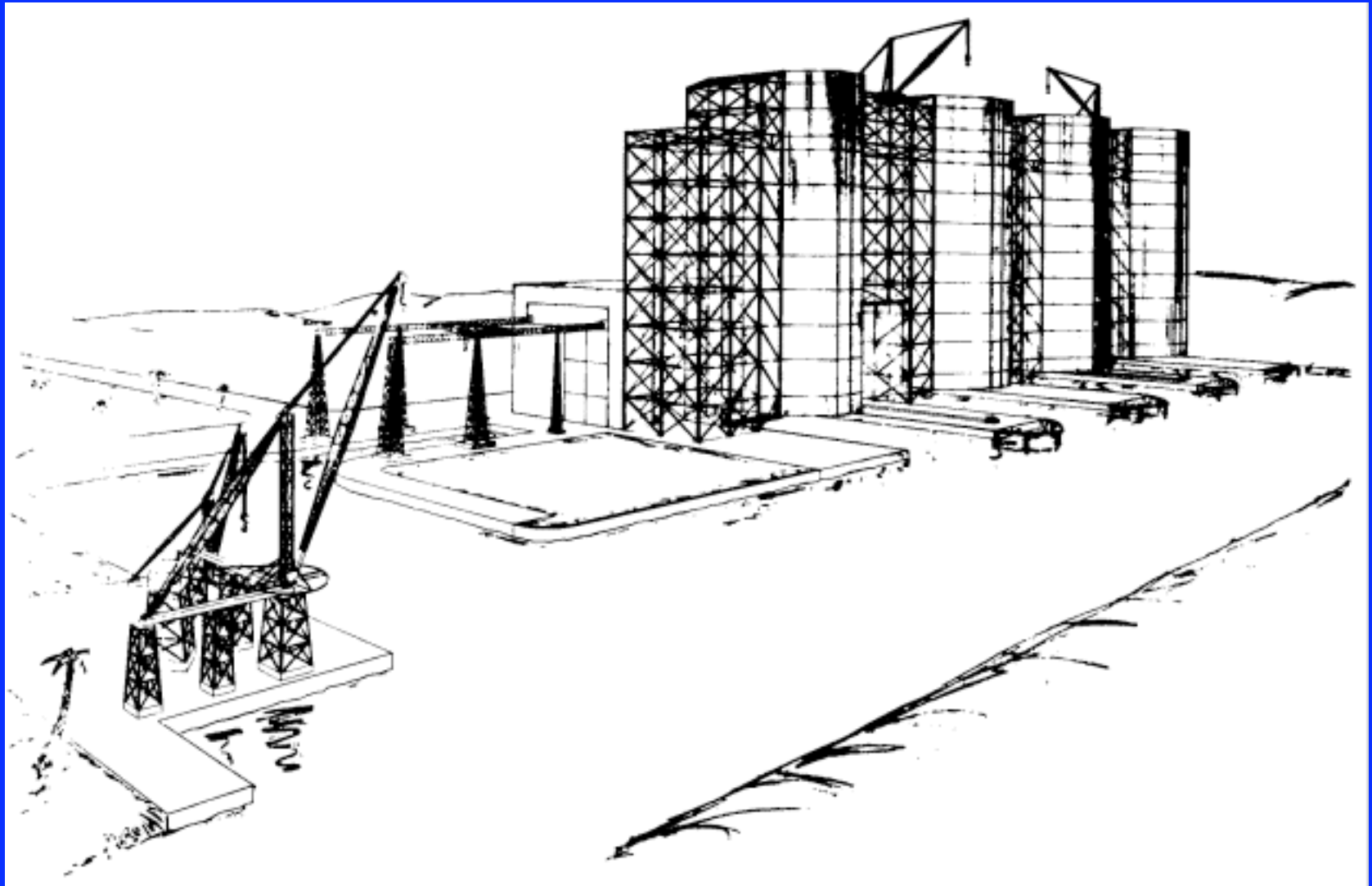

Barge-Based VAB (Enclosed)

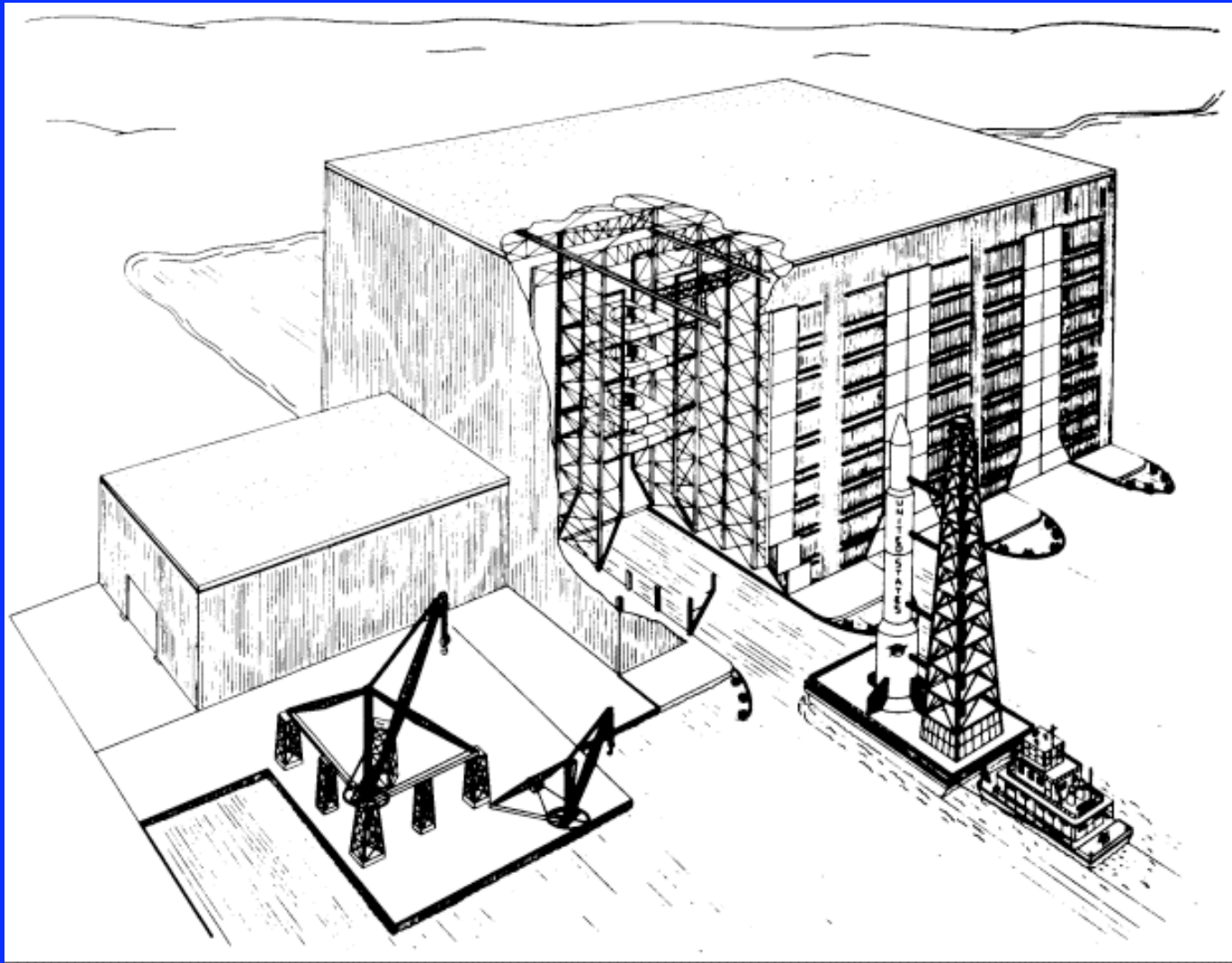

West Virginia Strip-Mine Coal Shovel

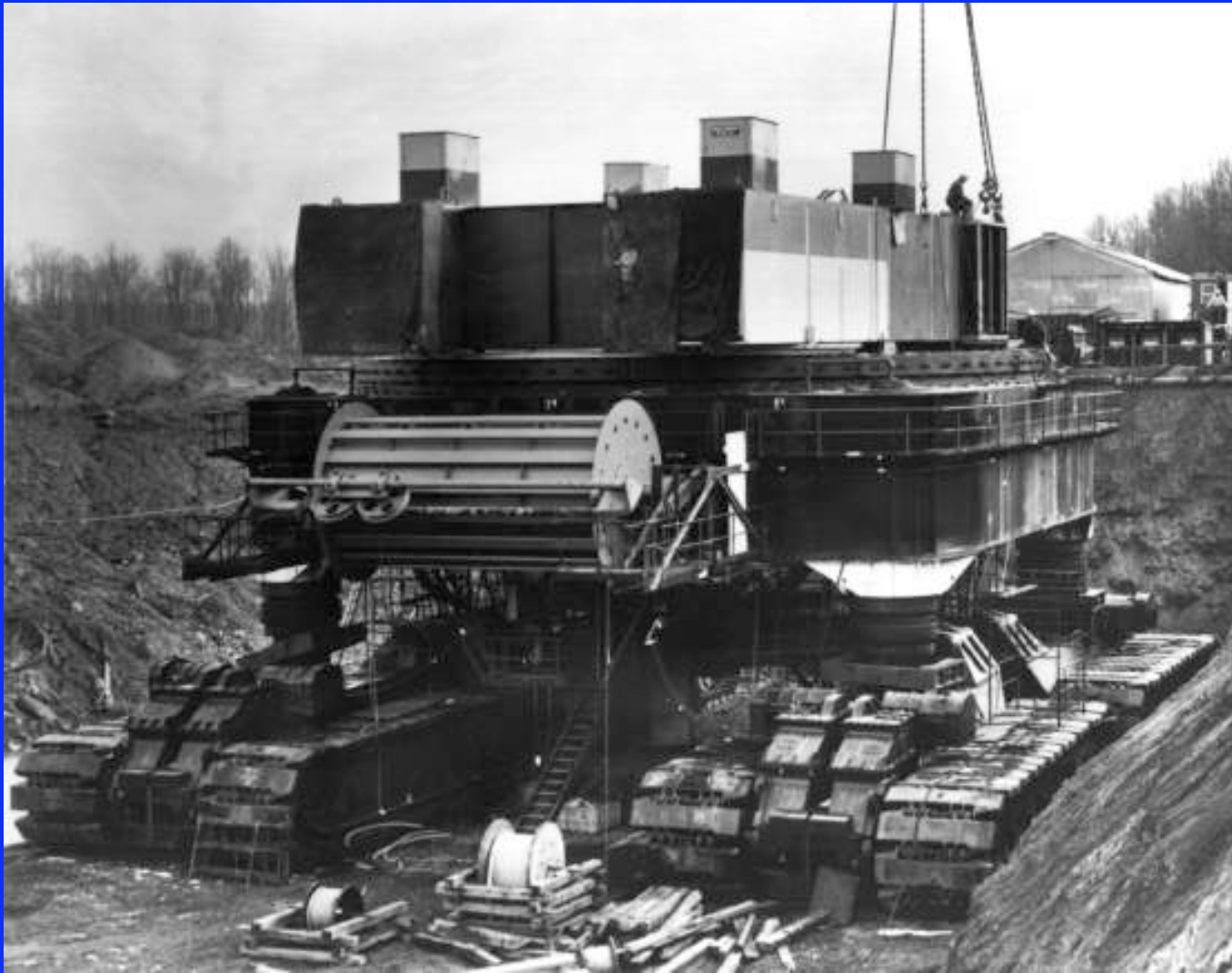

Expenditures for LC-39

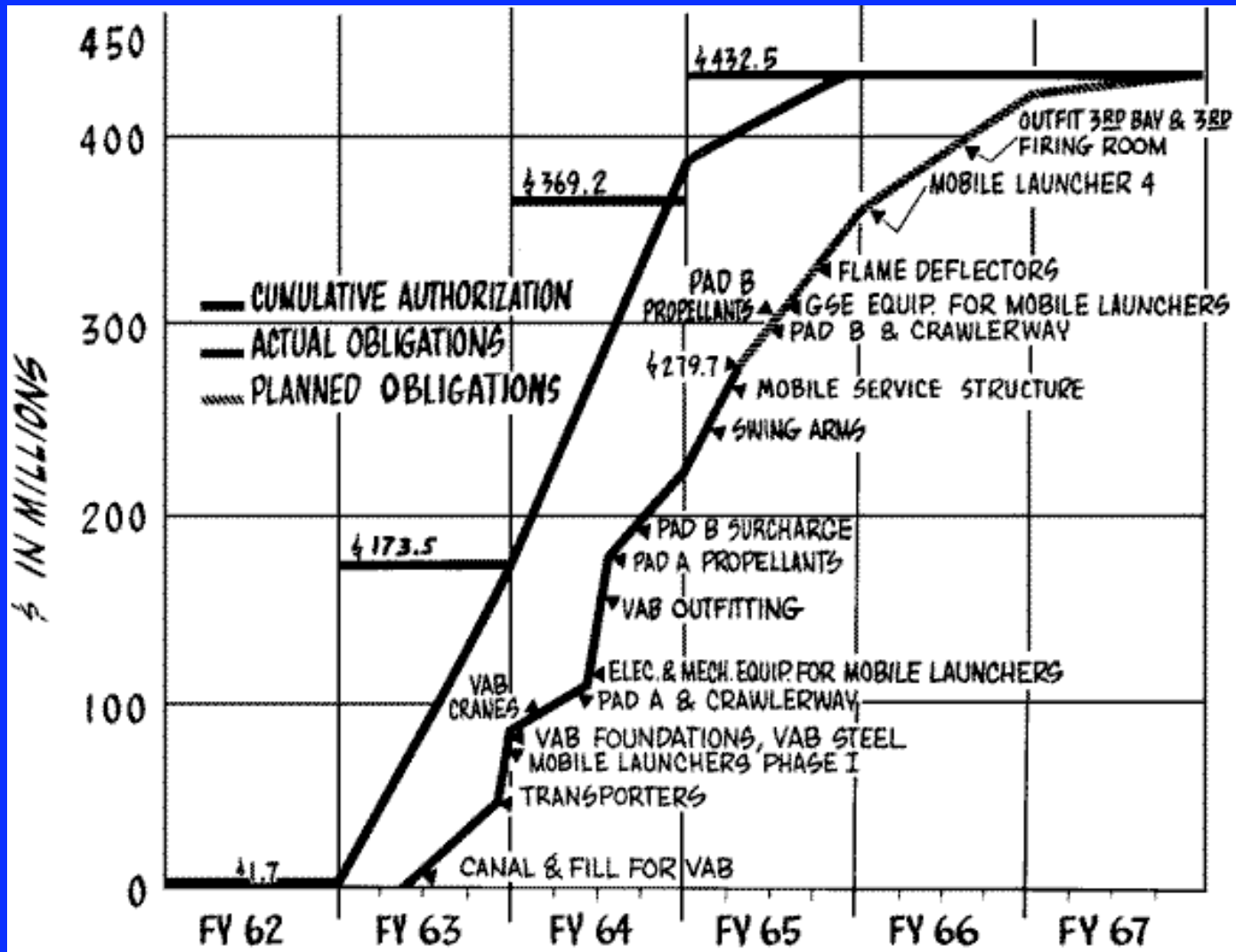

Aerial View of LC-34



LC-37 Concept

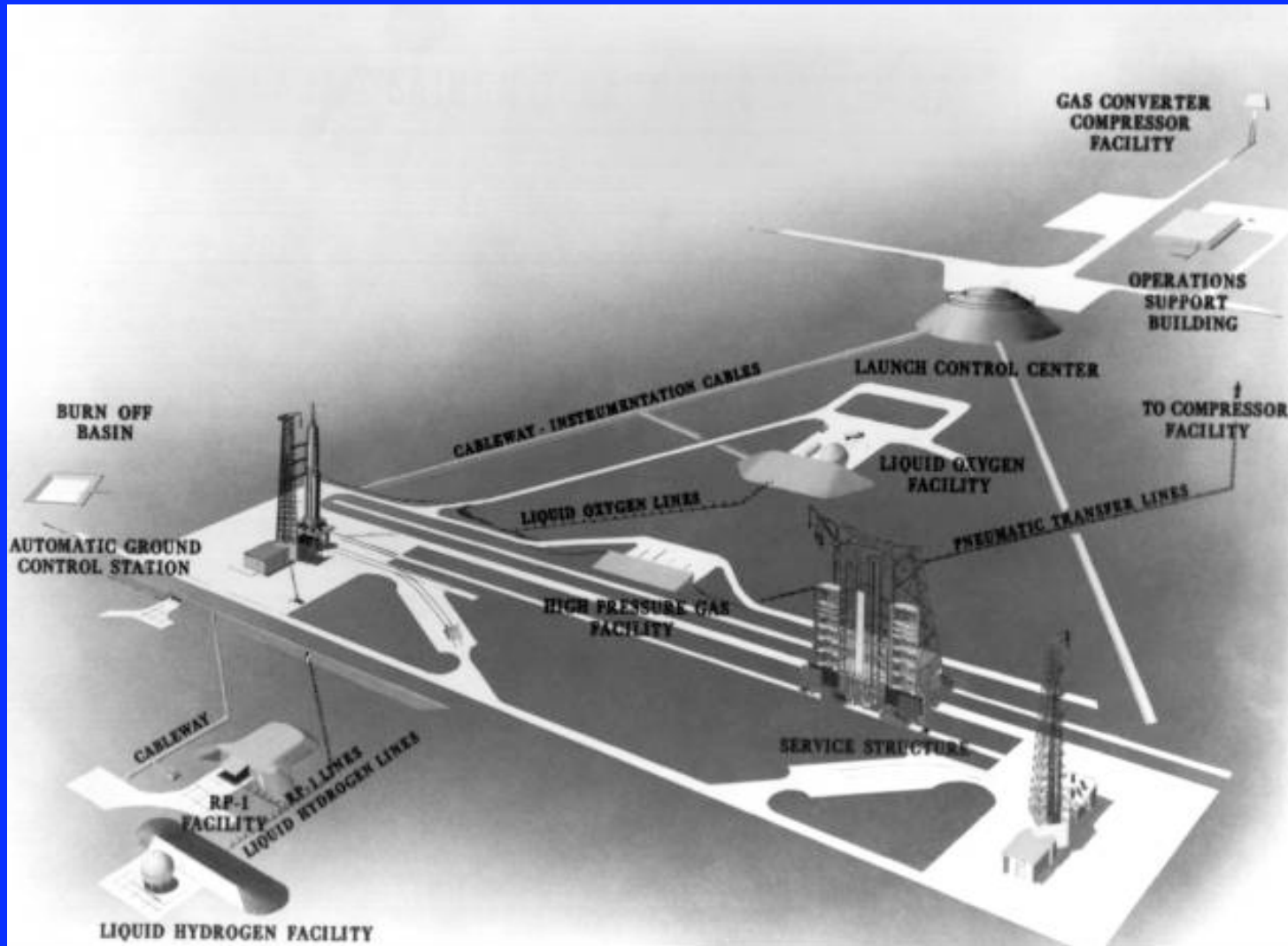



LC-37 Under Construction (1963)





UNIVERSITY
MARYLAND

g and Launch Facilities
Space Systems Design

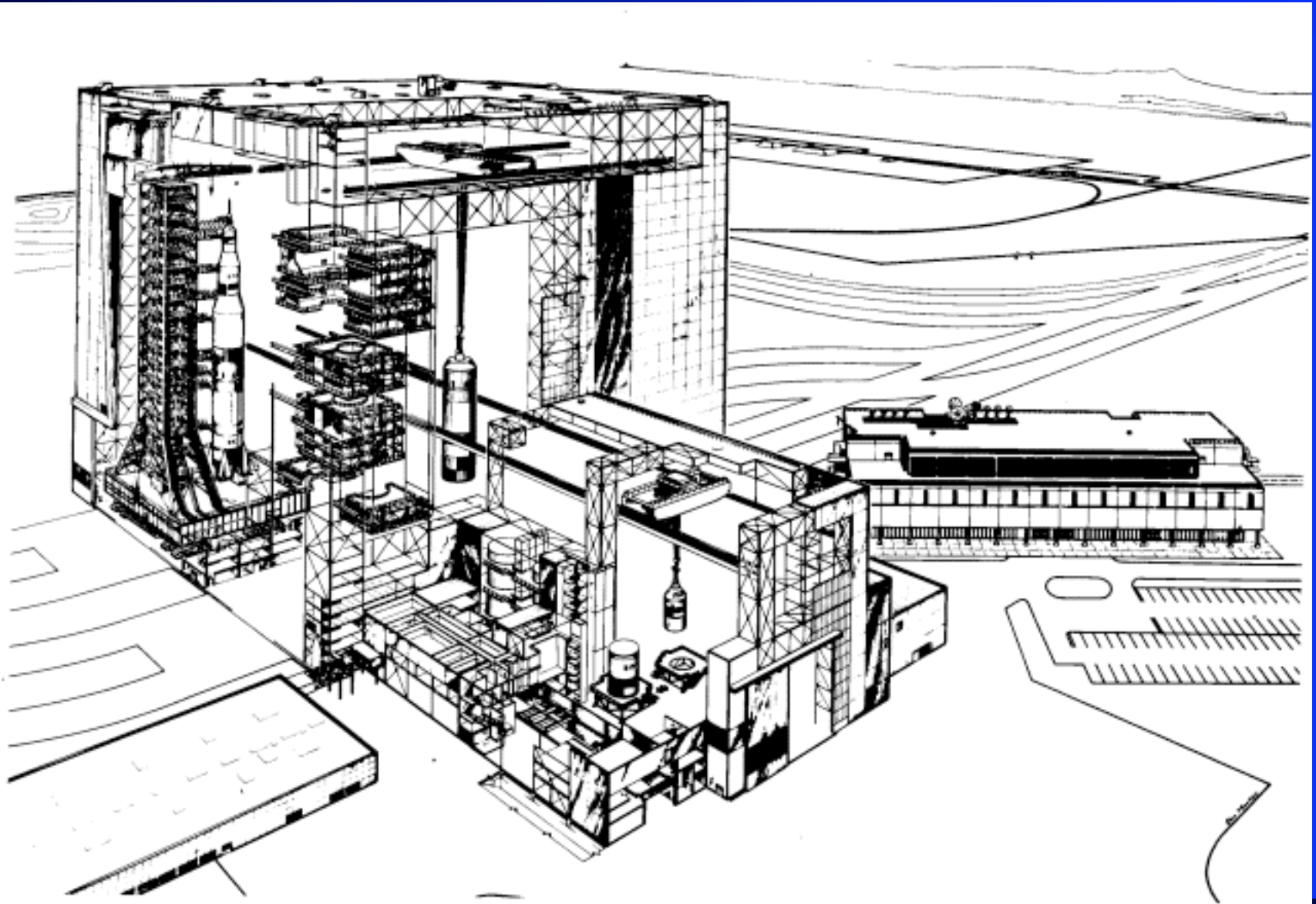

UNIVERSITY OF
MARYLAND

Ground Processing and Launch Facilities
Principles of Space Systems Design

PROFILE OF TYPICAL CRAWLERWAY SECTION

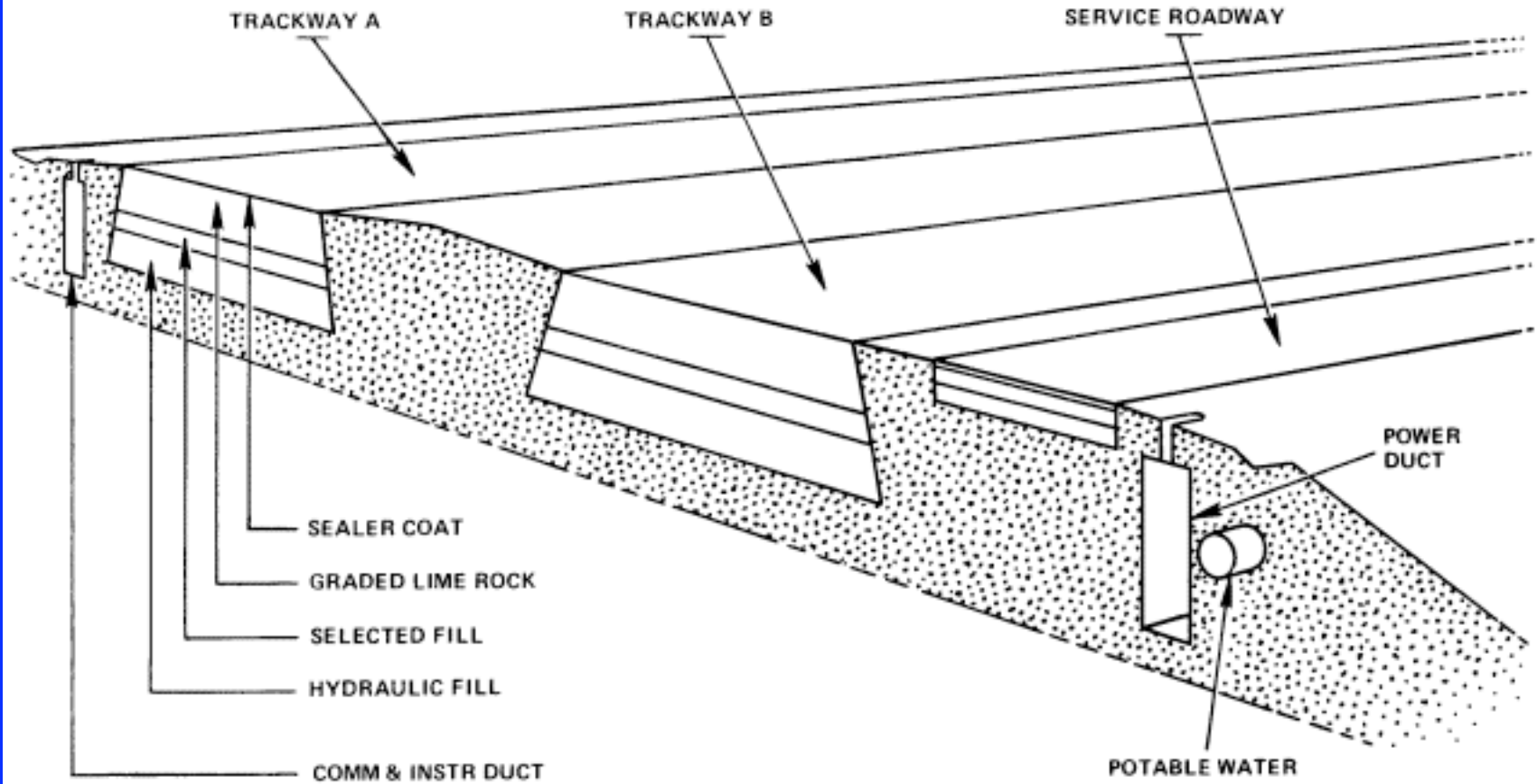

(NOT TO SCALE)



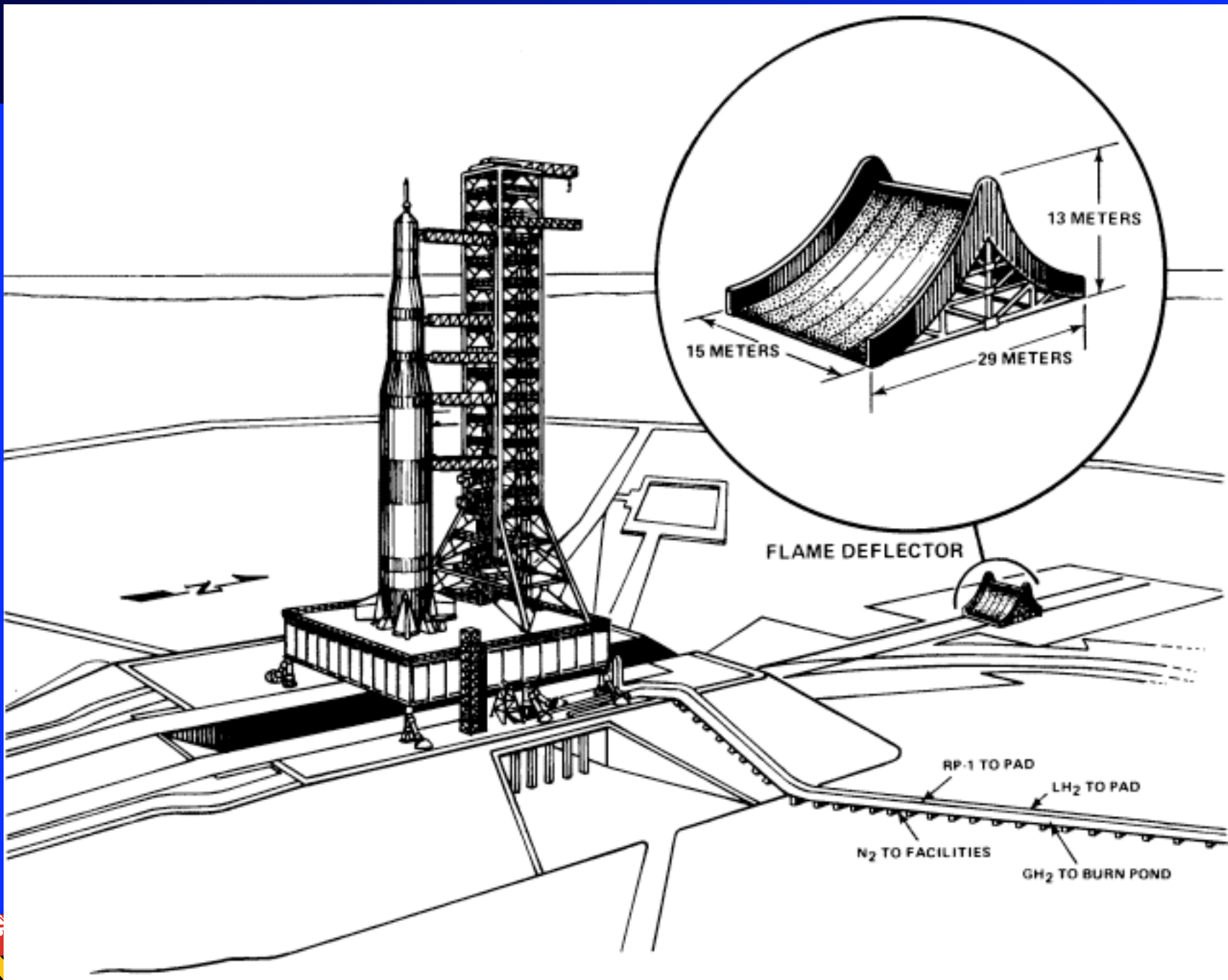



UNIVERSITY OF
MARYLAND

Ground Processing and Launch Facilities
Principles of Space Systems Design



UNIVERSITY OF
MARYLAND

Ground Processing and Launch Facilities
Principles of Space Systems Design

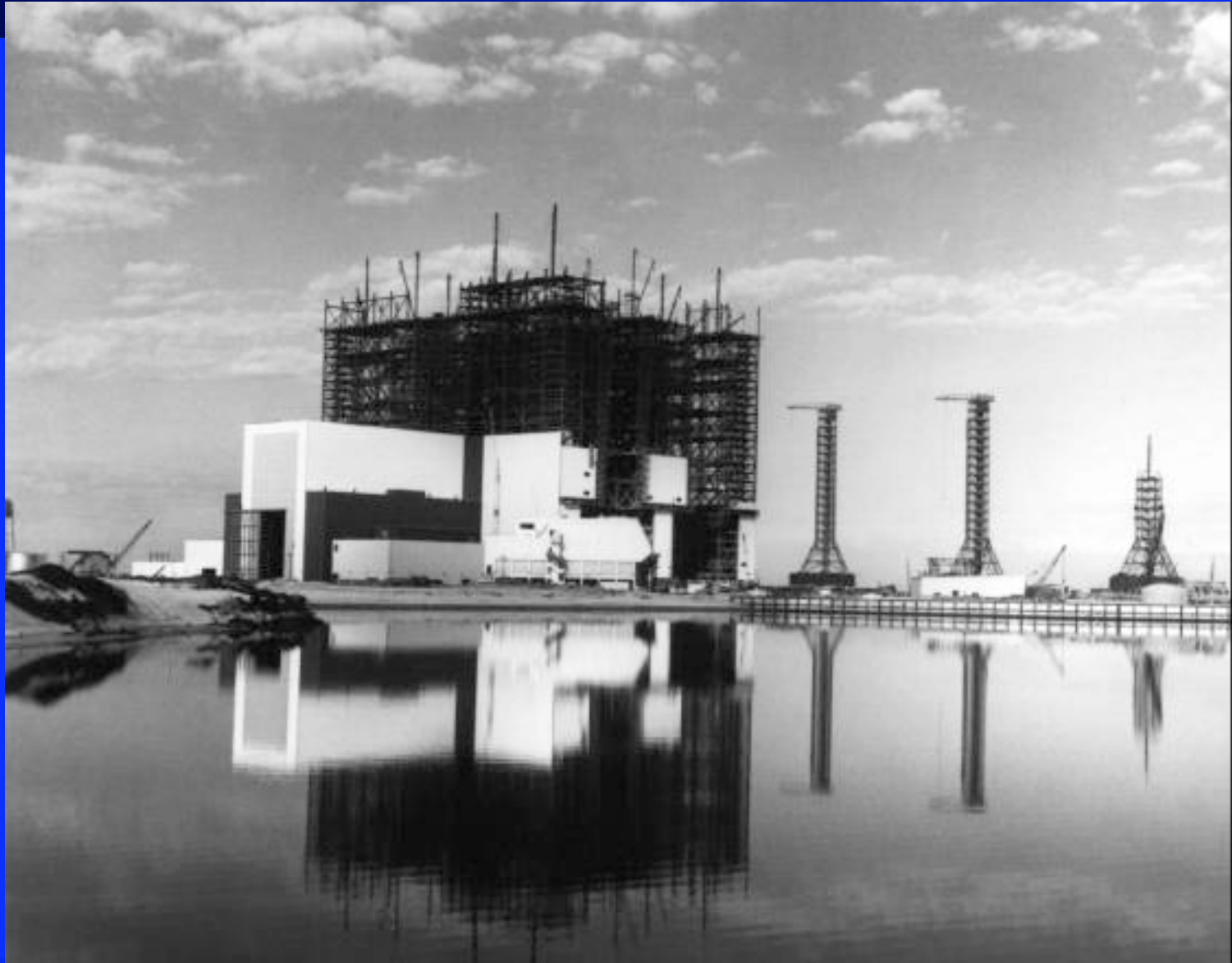

UNIVERSITY OF
MARYLAND

Ground Processing and Launch Facilities
Principles of Space Systems Design



UNIVERSITY OF
MARYLAND

Ground Processing and Launch Facilities
Principles of Space Systems Design



UNIVERSITY OF
MARYLAND

Ground Processing and Launch Facilities
Principles of Space Systems Design

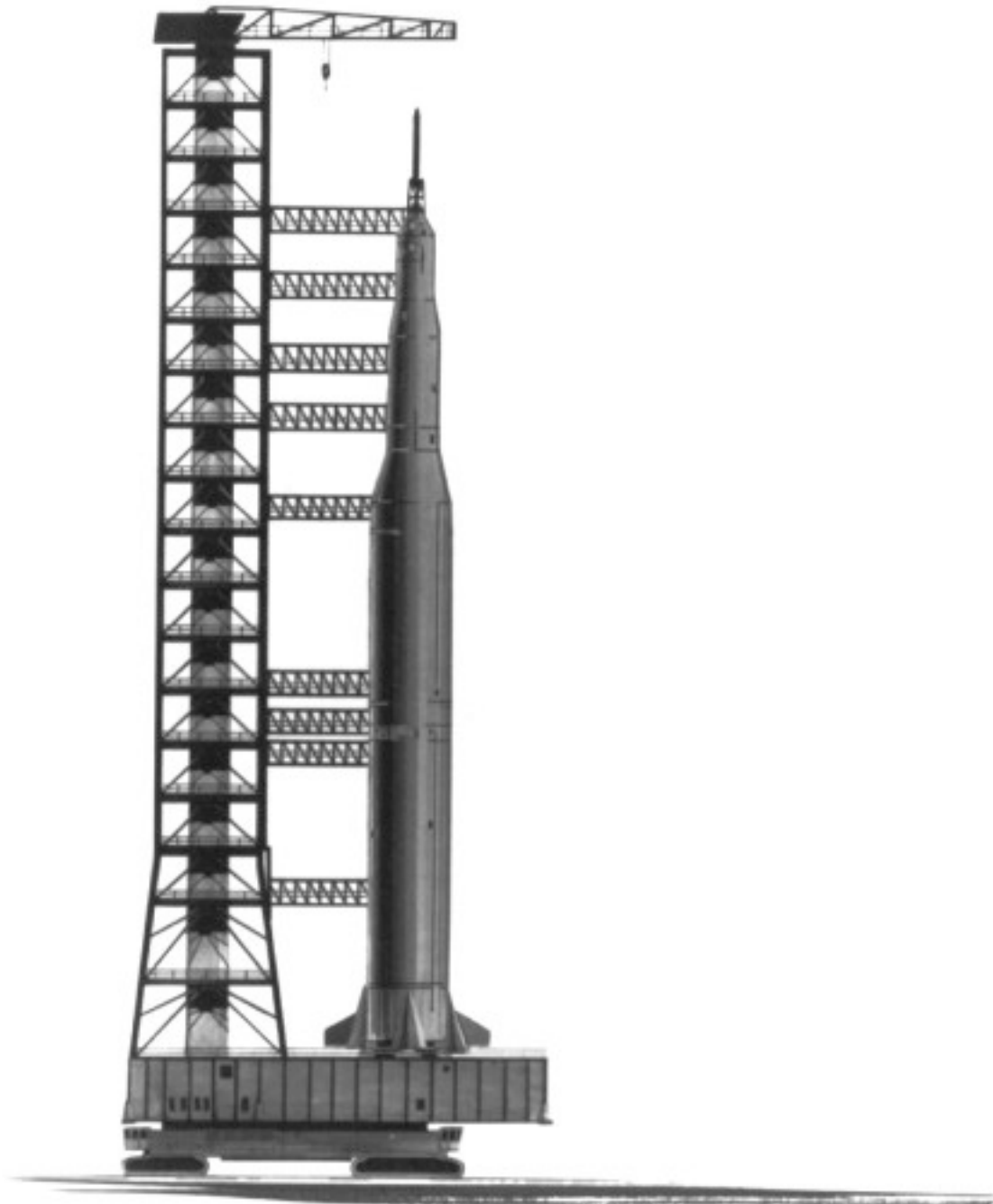

THE CRAWLER-TRANSPORTER

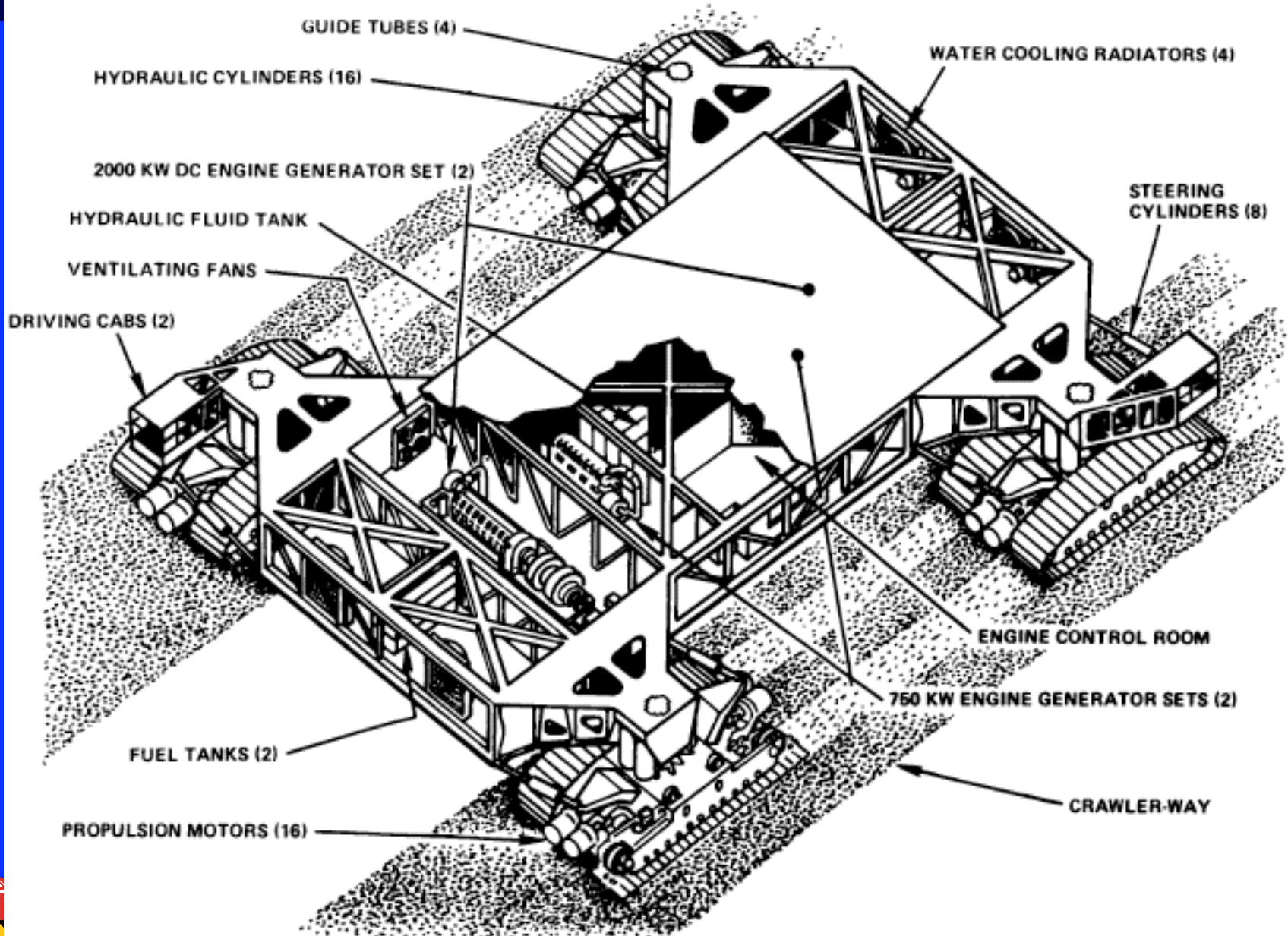



UNIVERSITY OF
MARYLAND

Ground Processing and Launch Facilities
Principles of Space Systems Design



UNIVERSITY OF
MARYLAND

Ground Processing and Launch Facilities
Principles of Space Systems Design

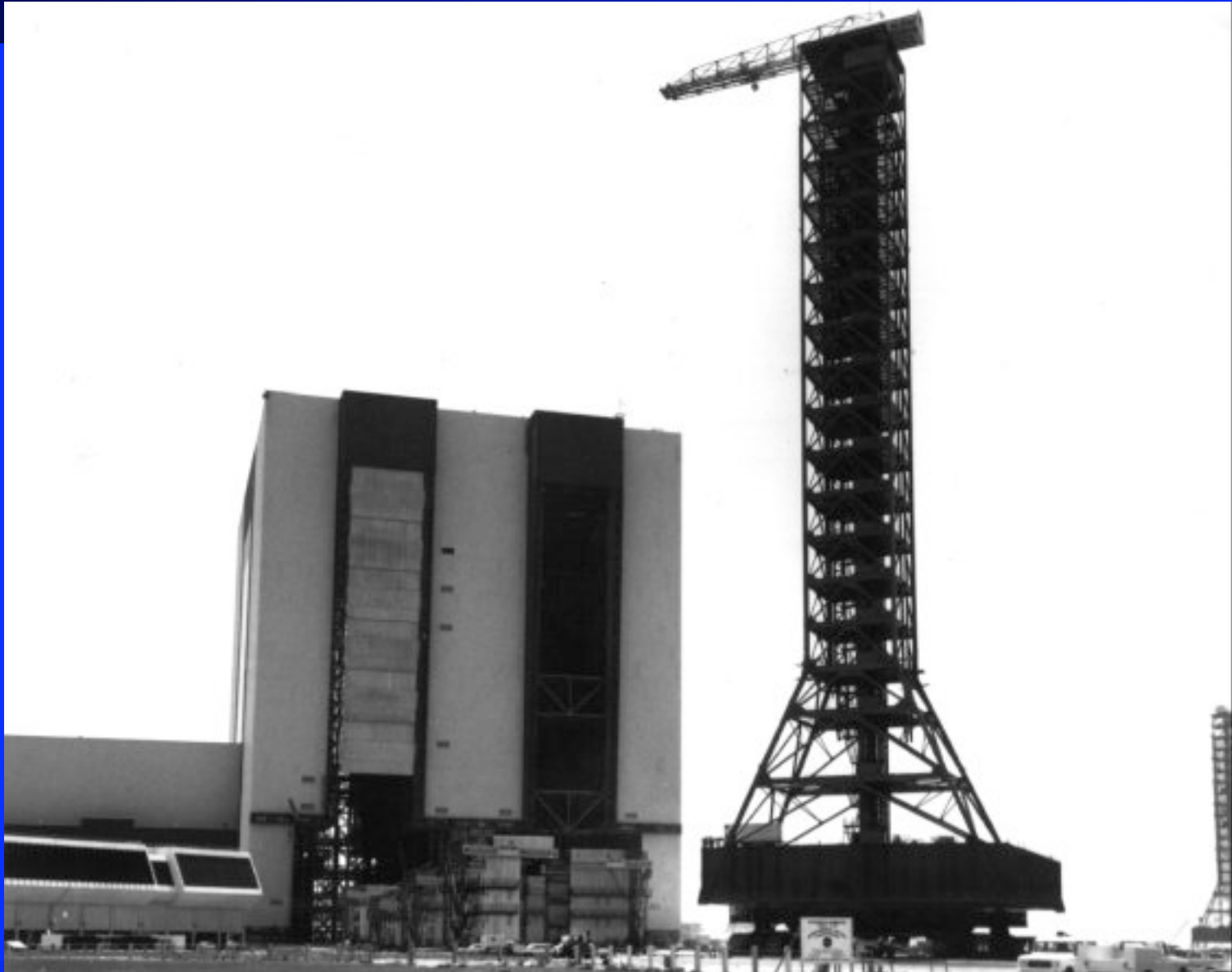

UNIVERSITY OF
MARYLAND

Ground Processing and Launch Facilities
Principles of Space Systems Design

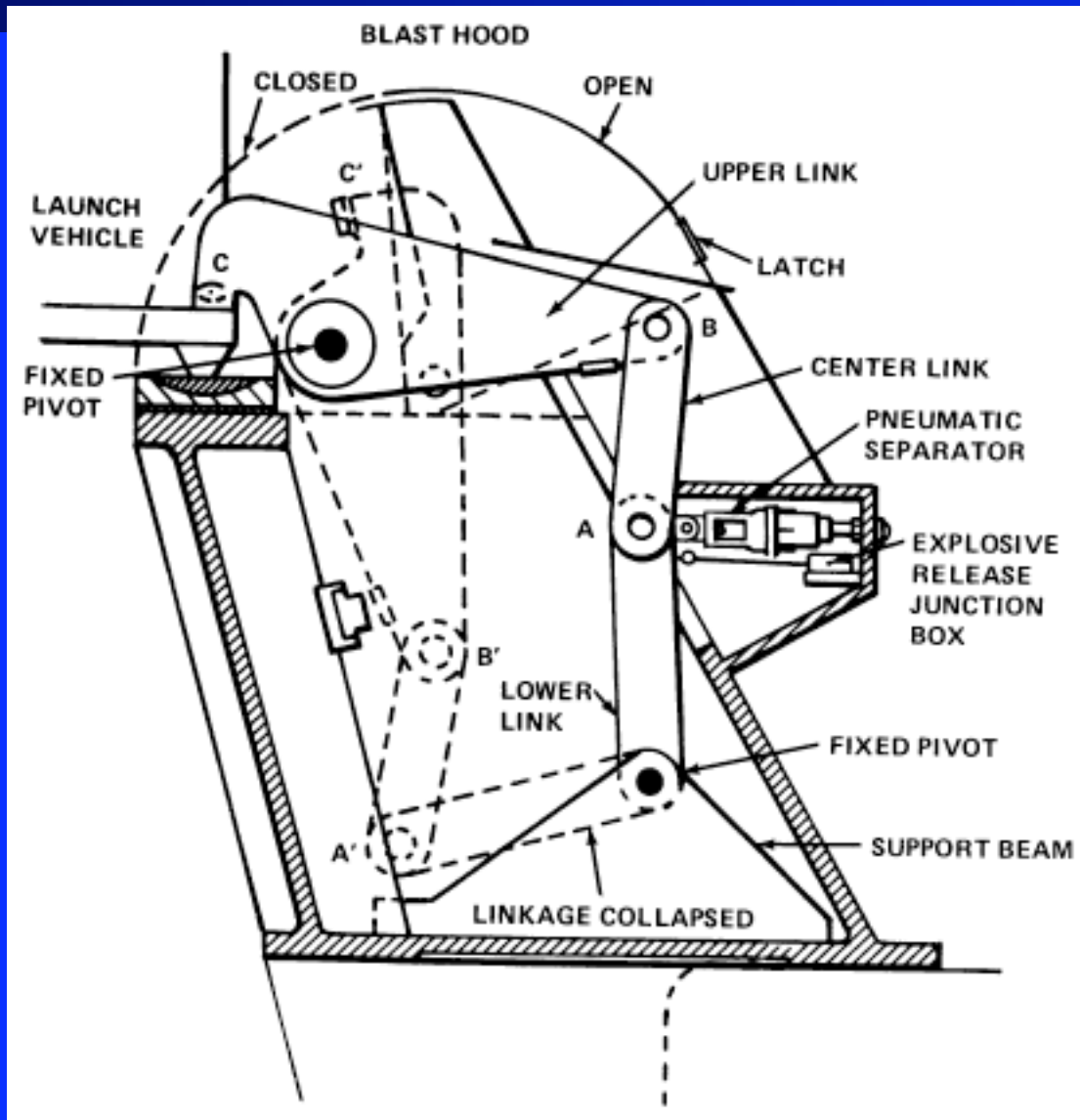

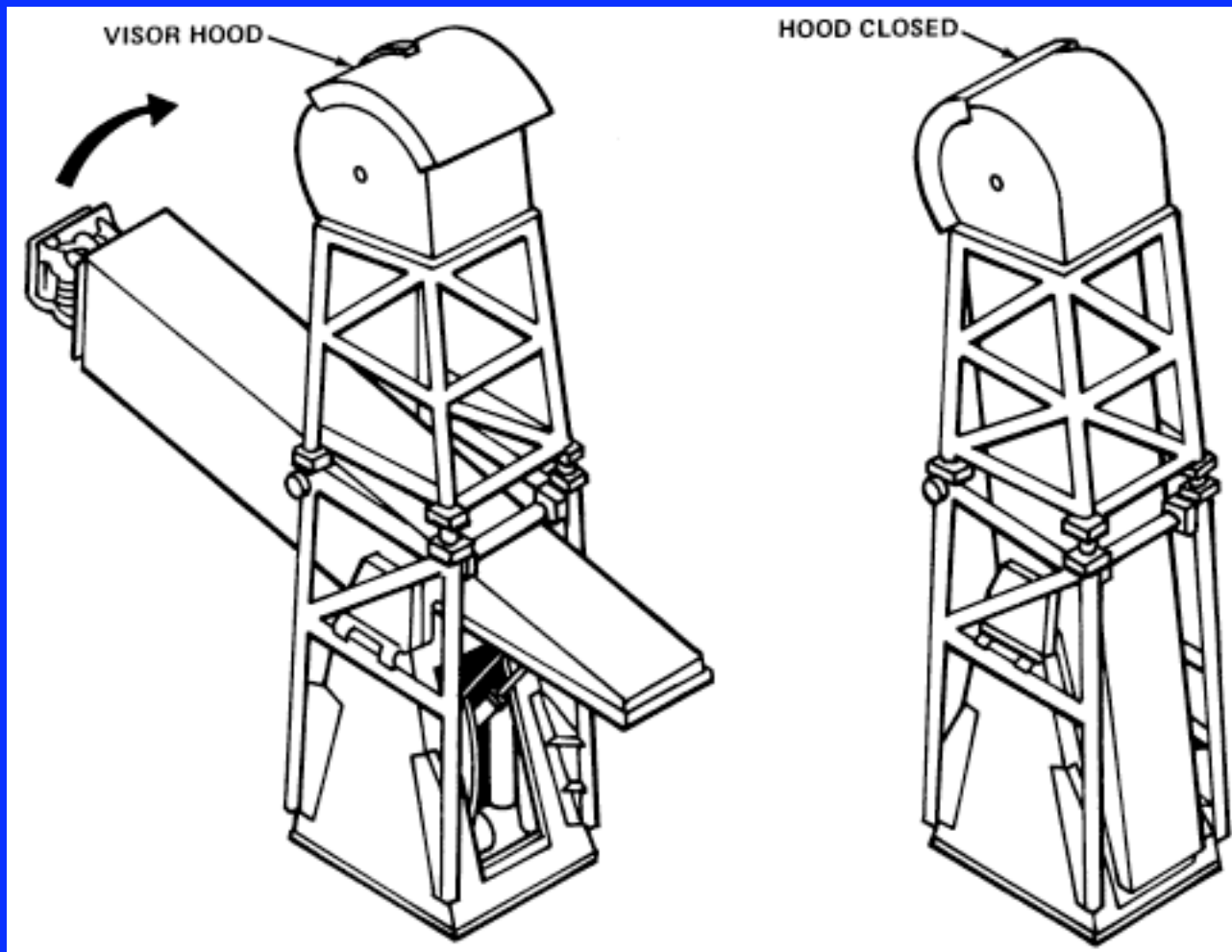





UNIVERSITY
MARYLAND

ing and Launch Facilities
of Space Systems Design

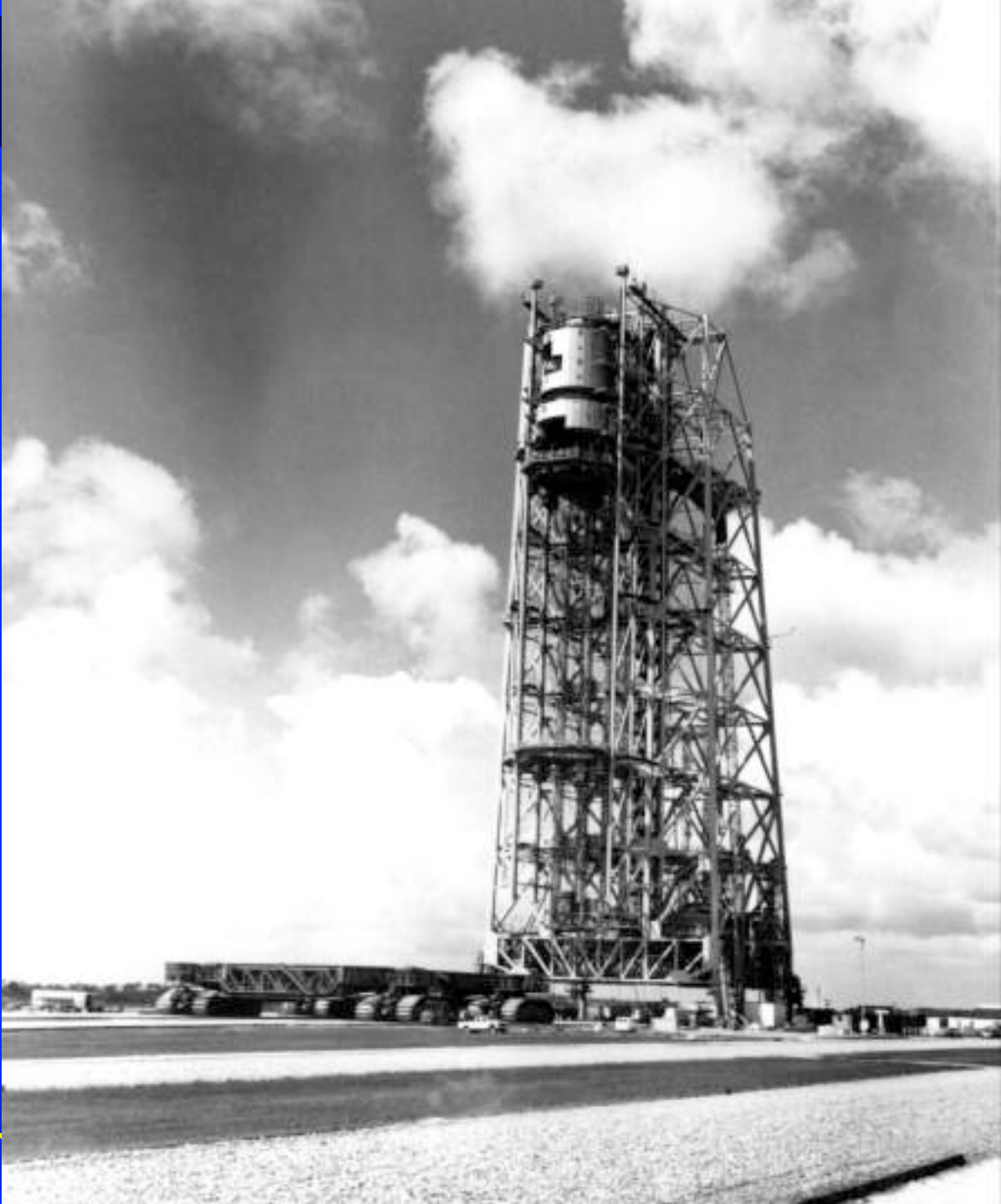

UNIVERSITY OF
MARYLAND

Launch Facilities
Design Systems Design



UM

Facilities
Design

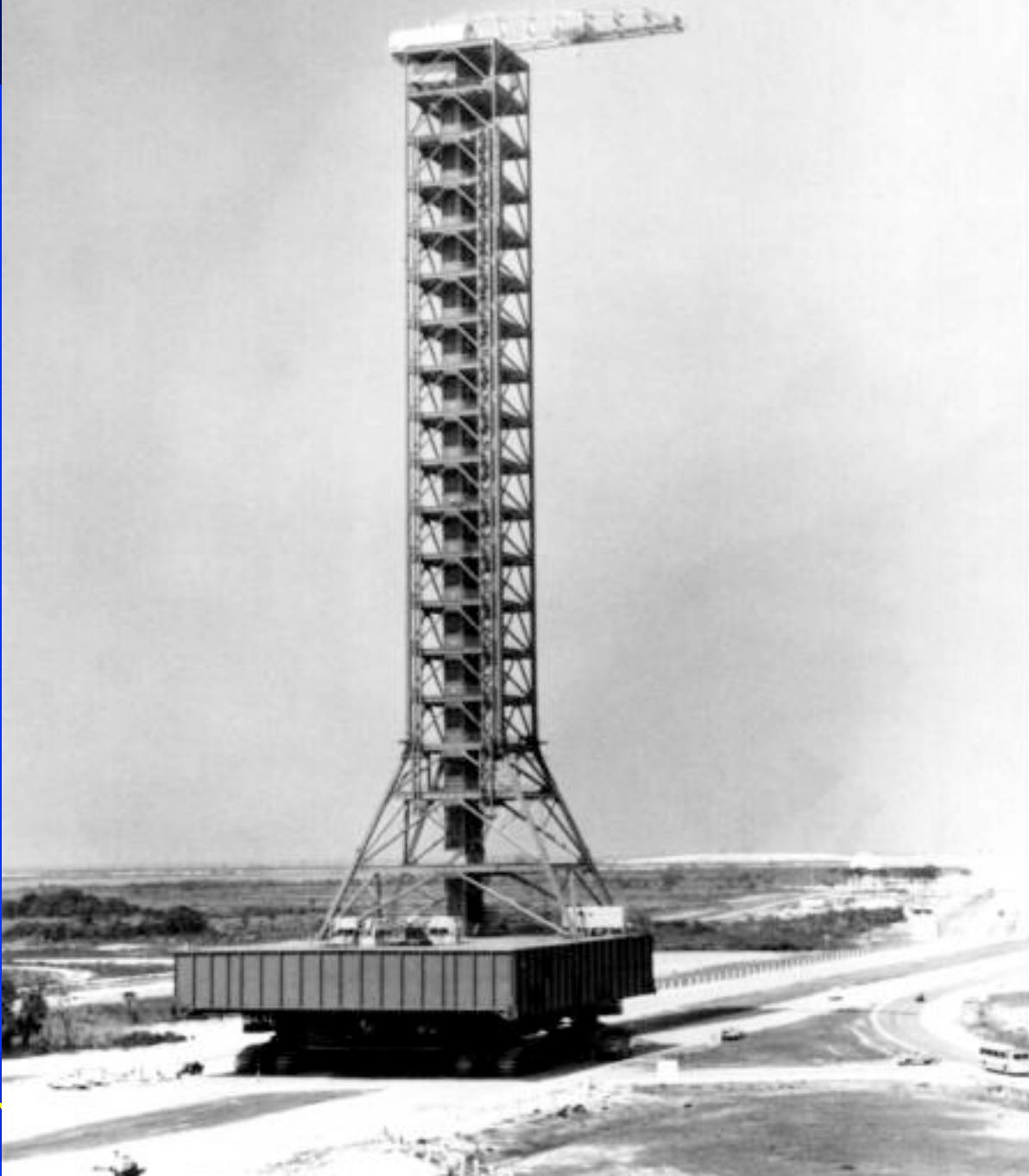

UNIVERSITY OF
MARYLAND

Launch Facilities
Structure Systems Design



VERTICAL ASSEMBLY BUILDING

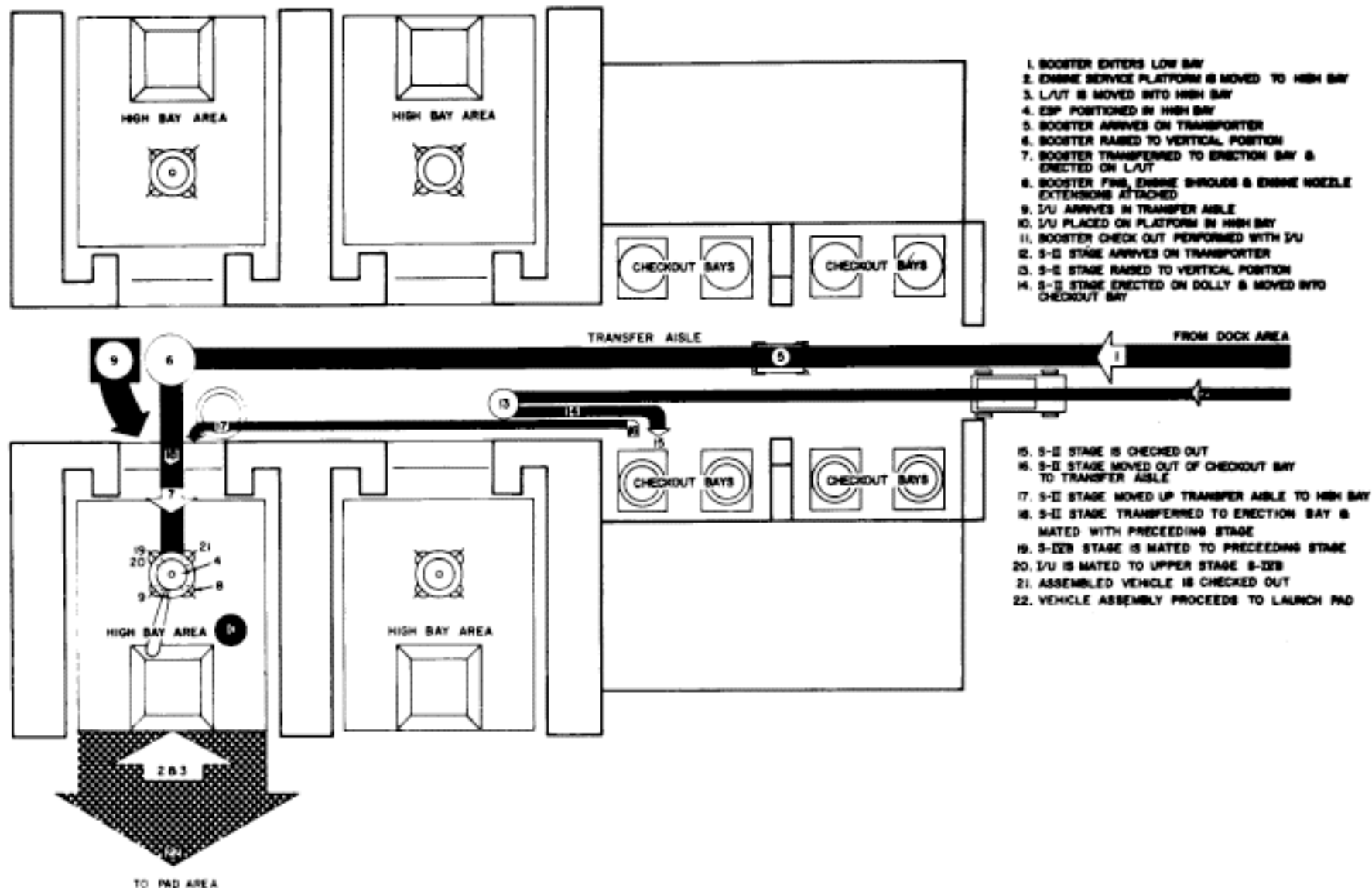

FLOW CHART



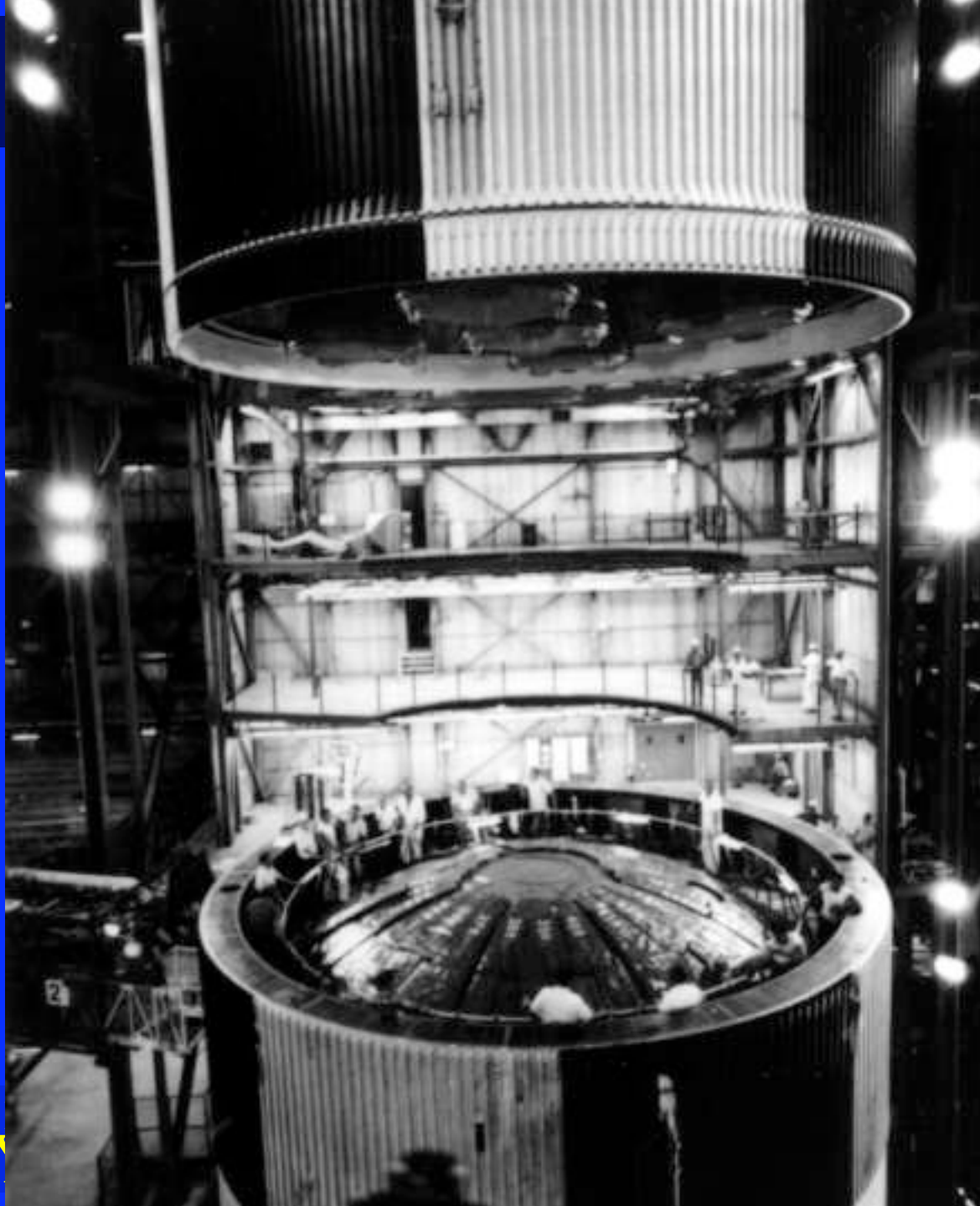



UNIVERSITY OF
MARYLAND

Launch Facilities
Space Systems Design

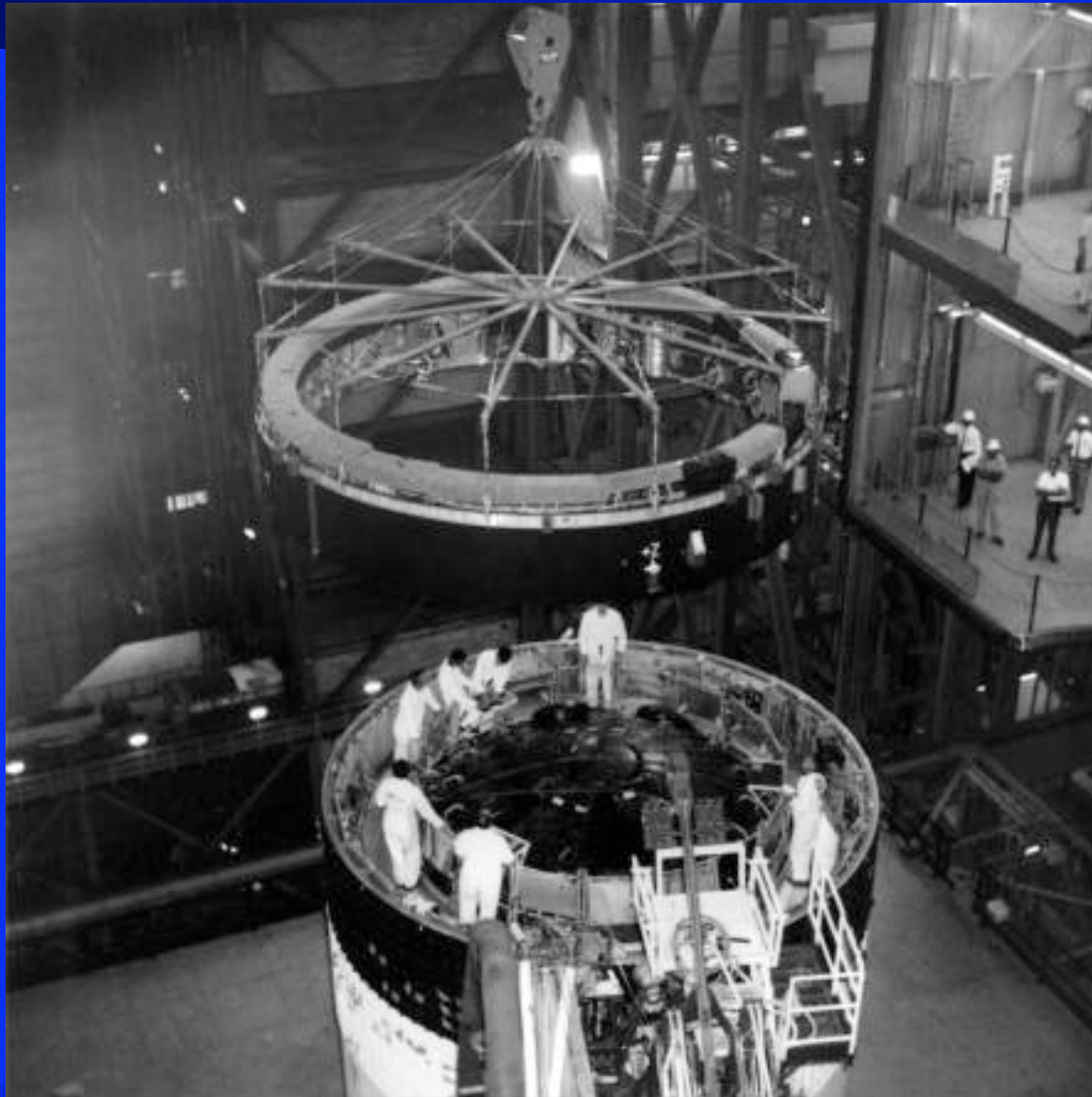

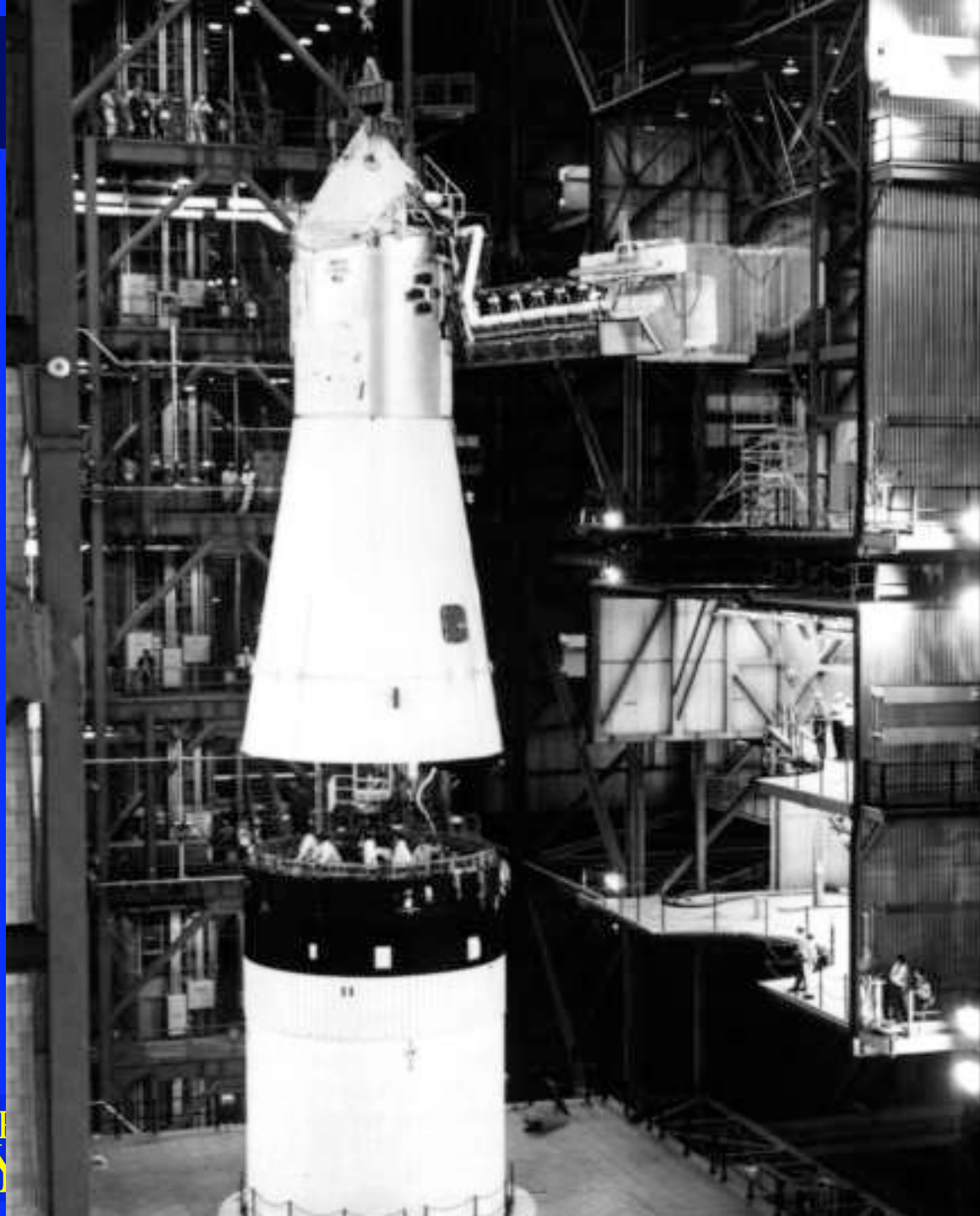

UNIVERSITY OF
MARYLAND

and Launch Facilities
Space Systems Design

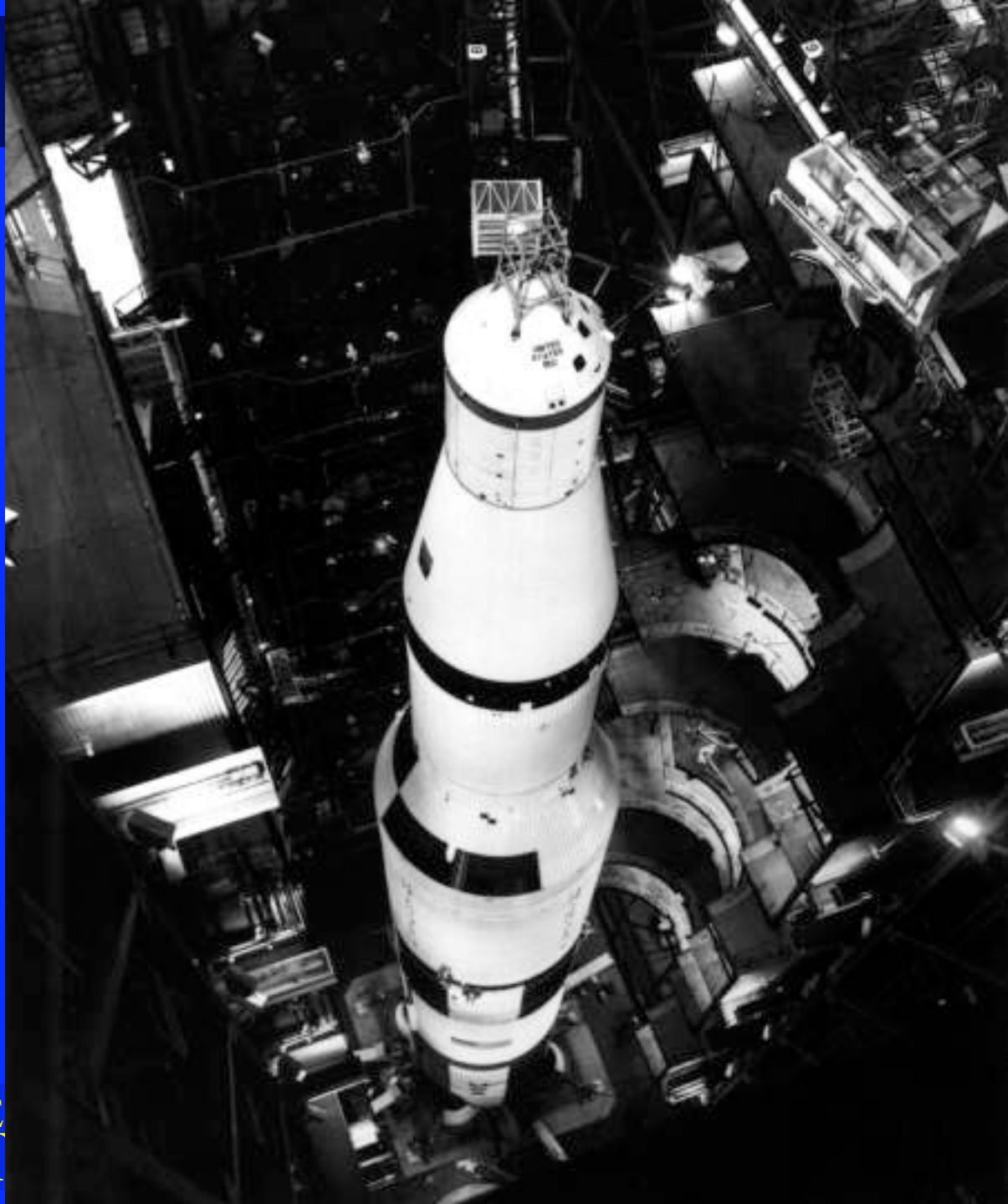

SATURN V CHECKOUT SCHEDULE MILESTONES

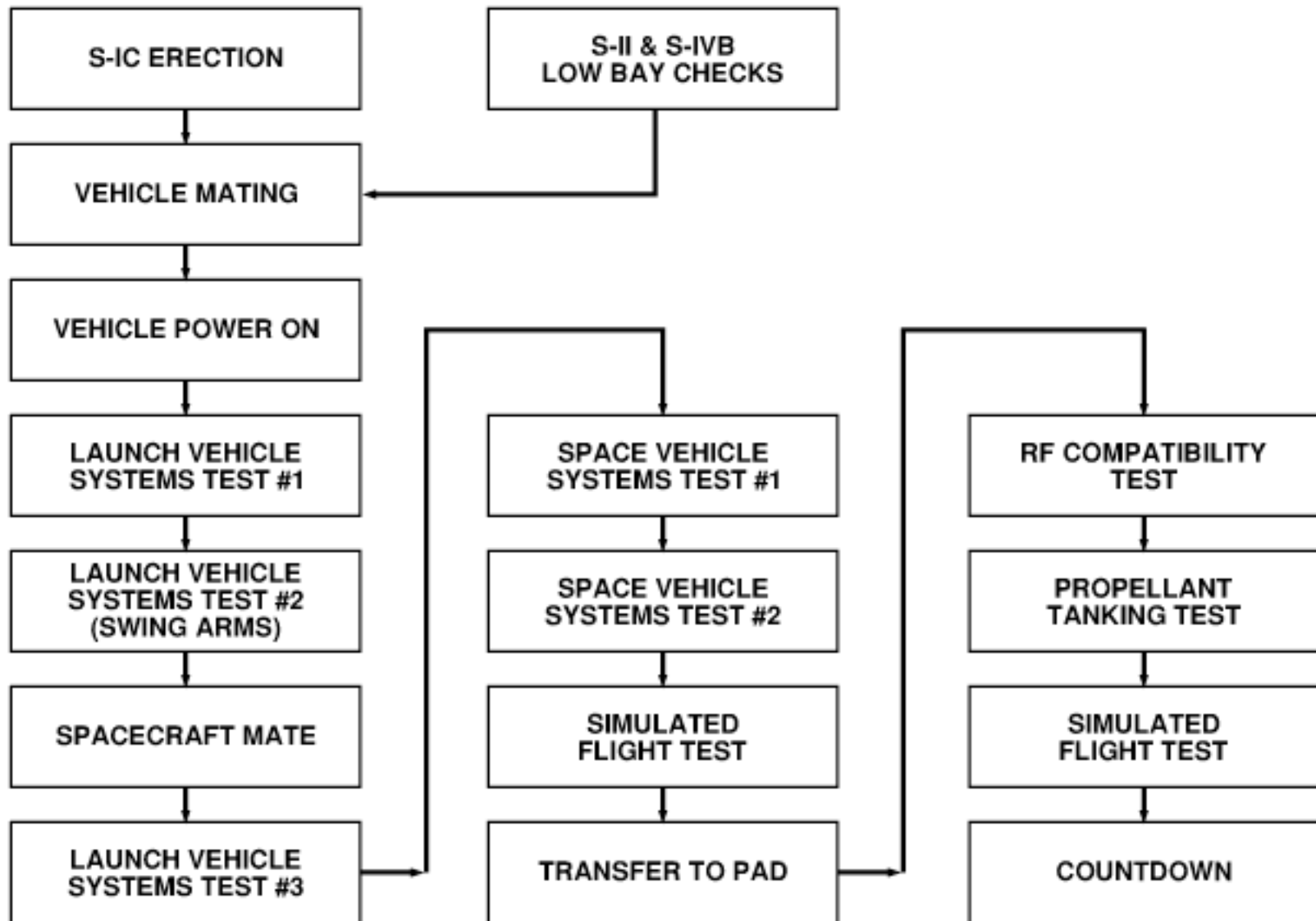



SA-501 at LC-39A

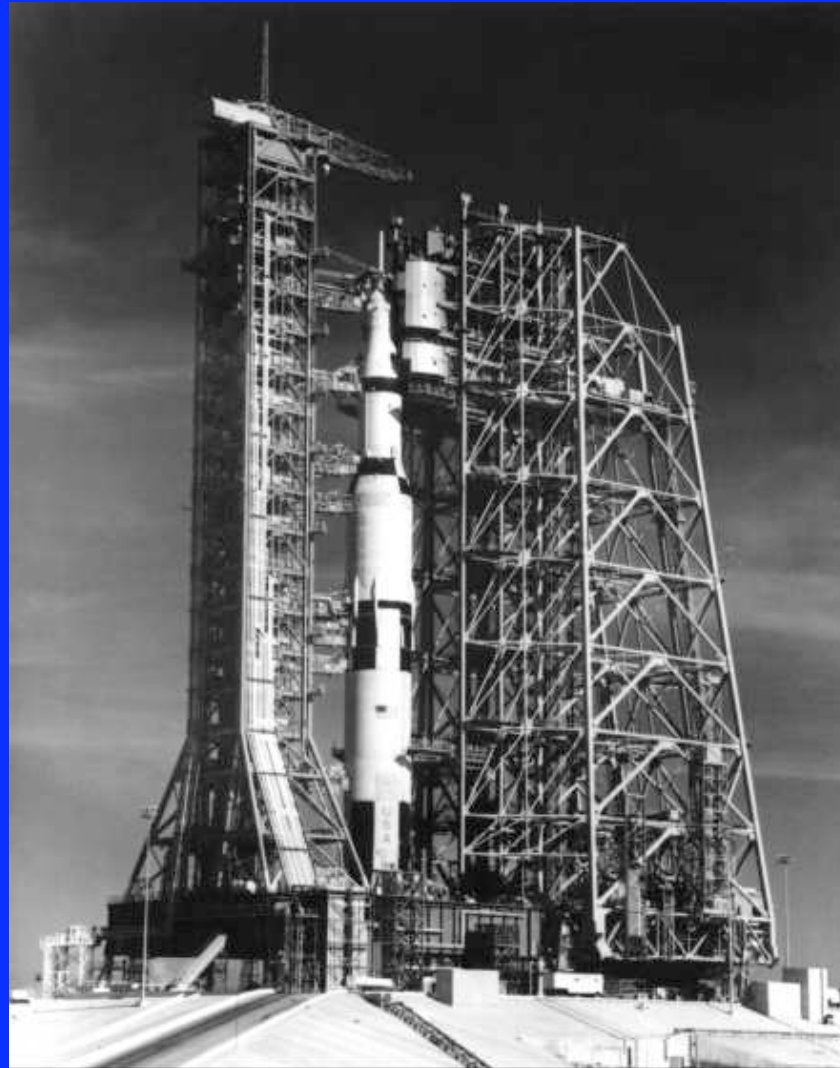

Delta IVH Horizontal Integration Facility



Delta IV Heavy Transporter



Delta IV Heavy at LC34 Blockhouse



Delta IV Heavy Arrives at LC-34



Delta IV Heavy Module Interconnects



Delta IV Heavy at Pad



Delta IV Heavy Rotation



Delta IV Heavy Rotation



Delta IV Heavy at Pad

