

Mass Estimating Relationships

- Mass Estimating Relationships (MERs)
- Sample vehicle design analysis



Akin's Laws of Spacecraft Design - #3

Design is an iterative process. The necessary number of iterations is one more than the number you have currently done. This is true at any point in time.



Vehicle-Level Preliminary Design - 1st Pass

- Single Stage to Orbit (SSTO) vehicle
- 5000 kg payload
- LOX/LH2 propellants

- $I_{sp}=430$ sec

- $\delta=0.08$

$$r = e^{-\frac{\Delta V}{gI_{sp}}} = 0.1127$$

$$\lambda = r - \delta = 0.0327$$

$$M_0 = \frac{M_L}{\lambda} = 153,000 \text{ kg}$$

$$M_i = \delta M_0 = 12,240 \text{ kg}$$

$$M_p = M_0(1 - r) = 135,800 \text{ kg}$$



System-Level Estimation

- Start with propellant tanks (biggest part)
- LOX/LH2 engines generally run at mixture ratio of 6:1 (by weight)
 - LH2: 19,390 kg
 - LOX: 116,400 kg
- Propellant densities

$$\rho_{LOX} = 1140 \frac{kg}{m^3} \quad \rho_{LH_2} = 112 \frac{kg}{m^3}$$



LOX Tank MERs

- Mass of Tank

$$M_{LOX Tank} (kg) = 0.0152 M_{LOX} (kg) + 318$$

- Mass of Insulation

$$M_{LOX Insulation} (kg) = 1.123 \frac{kg}{m^2}$$



LOX Tank Design

- Mass of LOX=116,400 kg

$$M_{LOX Tank} (kg) = 0.0152(116,400) + 318 = 2087 kg$$

- Need area to find LOX tank insulation mass
- assume a sphere

$$V_{LOX Tank} = M_{LOX} / \rho_{LOX} = 102.1 m^3$$

$$r_{LOX Tank} = \left(\frac{V_{LOX}}{4\pi / 3} \right)^{1/3} = 2.90 m$$
$$A_{LOX Tank} = 4\pi r_{LOX}^2 = 105.6 m^2$$

$$M_{LOX Insulation} (kg) = 1.123 \frac{kg}{m^2} (105.6 m^2) = 119 kg$$

LH2 Tank MERs

- Mass of Tank

$$M_{LH_2 \text{ Tank}} (kg) = 0.0694 M_{LH_2} (kg) + 363$$

- Mass of Insulation

$$M_{LH_2 \text{ Insulation}} (kg) = 2.88 \frac{kg}{m^2}$$



LH2 Tank Design

- Mass of LH2=19,390 kg

$$M_{LH_2 Tank} (kg) = 0.0694(19,390) + 363 = 1709 kg$$

- Again, assume LH2 tank is spherical

$$V_{LH_2 Tank} = M_{LH_2} / \rho_{LH_2} = 346.3 m^3$$

$$r_{LH_2 Tank} = \left(\frac{V_{LH_2}}{4\pi/3} \right)^{1/3} = 3.46 m$$

$$A_{LH_2 Tank} = 4\pi r_{LH_2}^2 = 150.2 m^2$$

$$M_{LH_2 Insulation} (kg) = 2.88 \frac{kg}{m^2} (150.2 m^2) = 433 kg$$



Current Design Sketch

- **Masses**

- LOX Tank 2089 kg
- LOX Tank Insulation 1709 kg
- LH2 Tank 119 kg
- LH2 Tank Insulation 433 kg

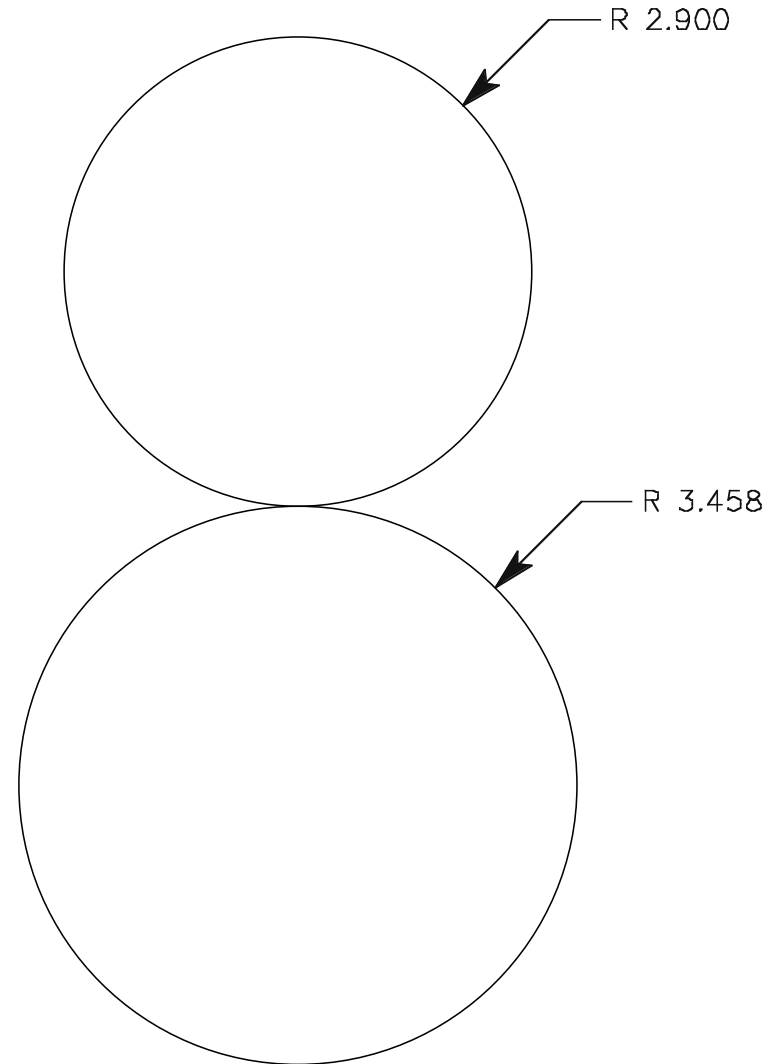

Other Tankage MERs

- Storable Propellants (RP-1, N_2O_4 , N_2H_4)

$$M_{Storables\ Tank} (kg) = 0.316 [M_{Storables} (kg)]^{.6}$$

- Small tank (liquids)

$$M_{Small\ Liquid\ Tank} (kg) = 0.1 M_{contents} (kg)$$

- Small tank (pressurized gases)

$$M_{Small\ Gas\ Tank} (kg) = 2 M_{contents} (kg)$$





Boost Module Propellant Tanks

- **Gross mass 23,000 kg**
 - Inert mass 2300 kg
 - Propellant mass 20,700 kg
 - Mixture ratio $N_2O_4/A50 = 1.8$ (by mass)
- **N_2O_4 tank**
 - Mass = 13,310 kg
 - Density = 1450 kg/m³
 - Volume = 9.177 m³ --> $r_{\text{sphere}}=1.299$ m
- **Aerozine 50 tank**
 - Mass = 7390 kg
 - Density = 900 kg/m³
 - Volume = 8.214 m³ --> $r_{\text{sphere}}=1.252$ m



N_2O_4 Tank Sizing

- **Need total N_2O_4 volume = 9.177 m³**
- **Single tank**
 - Radius = 1.299 m
 - Mass = 94.2 kg
- **Dual tanks**
 - Radius = 1.031 m
 - Mass = 62.2 kg (x2 = 124.3 kg)
- **Triple tanks**
 - Radius = 0.900 m
 - Mass = 48.7 kg (x3 = 146.2 kg)

Other Structural MERs

- Fairings and shrouds

$$M_{Fairing} (kg) = 13.3 \frac{kg}{m^2}$$

- Avionics

$$M_{Avionics} (kg) = 10 [M_0 (kg)]^{0.361}$$

- Wiring

$$M_{Wiring} (kg) = 1.058 \sqrt{M_0 (kg)} |^{0.25}$$



Fairing Analysis

- Payload Shroud
 - Area 51.74 m²
 - Mass 688 kg
- Intertank Fairing
 - Area 126.1 m²
 - Mass 1677 kg
- Aft Fairing
 - Area 107.7 m²
 - Mass 1433 kg

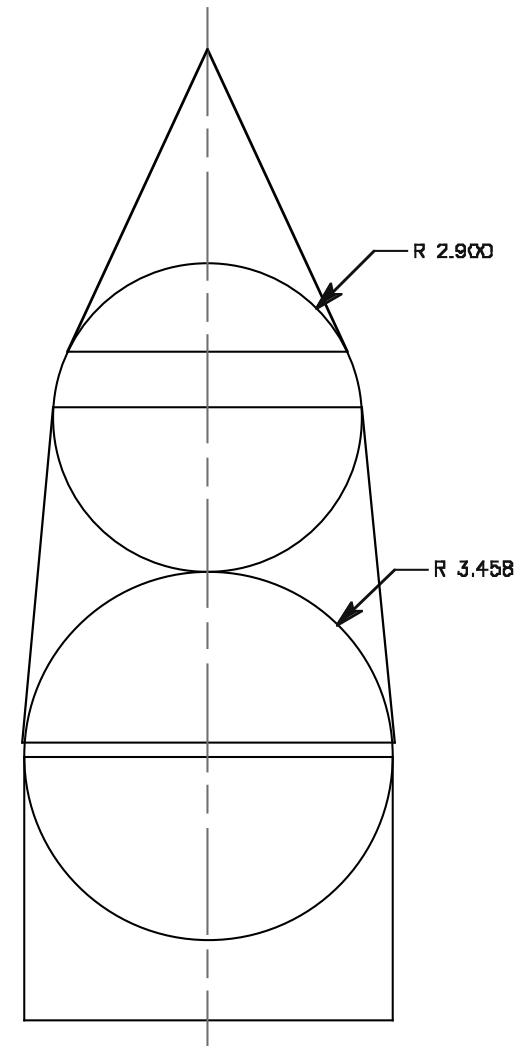

Avionics and Wiring Masses

- Avionics

$$M_{Avionics} (kg) = 10[153,000 kg]^{0.361} = 744 kg$$

- Wiring

$$M_{Wiring} (kg) = 1.058\sqrt{153,000} (16.95 m)^{0.25} = 840 kg$$



Propulsion MERs

- Liquid Pump-Fed Rocket Engine Mass

$$M_{\text{Rocket Engine}} (kg) = 7.81 \times 10^{-4} T(N) + 3.37 \times 10^{-5} T(N) \sqrt{\frac{A_e}{A_t}} + 59$$

- Solid Rocket Motor

$$M_{\text{Motor Casing}} = 0.135 M_{\text{propellants}}$$

- Thrust Structure Mass

$$M_{\text{Thrust Structure}} (kg) = 2.55 \times 10^{-4} T(N)$$



Propulsion MERs (continued)

- Gimbal Mass

$$M_{Gimbals} (kg) = 237.8 \left[\frac{T(N)}{P_0(Pa)} \right]^{.9375}$$

- Gimbal Torque

$$\tau_{Gimbals} (N \cdot m) = 990,000 \left[\frac{T(N)}{P_0(Pa)} \right]^{1.25}$$



Propulsion System Assumptions

- Initial T/mg ratio = 1.3
 - Keeps final acceleration low with reasonable throttling
- Number of engines = 6
 - Positive acceleration worst-case after engine out
- Chamber pressure = 1000 psi = 6897 kN
 - Typical for high-performance LOX/LH2 engines
- Expansion ratio $A_e/A_t=30$
 - Compromise ratio with good vacuum performance



Propulsion Mass Estimates

- Rocket Engine Thrust (each)

$$T(N) = \frac{m_0 g (T/W)_0}{n_{engines}} = 324,900 N$$

- Rocket Engine Mass (each)

$$M_{Rocket\ Engine} (kg) = 7.81 \times 10^{-4} (324,900) + 3.37 \times 10^{-5} (324,900) \sqrt{30} + 59 = 373 kg$$

- Thrust Structure Mass

$$M_{Thrust\ Structure} (kg) = 2.55 \times 10^{-4} (324,900) = 497 kg$$



First Pass Vehicle Configuration

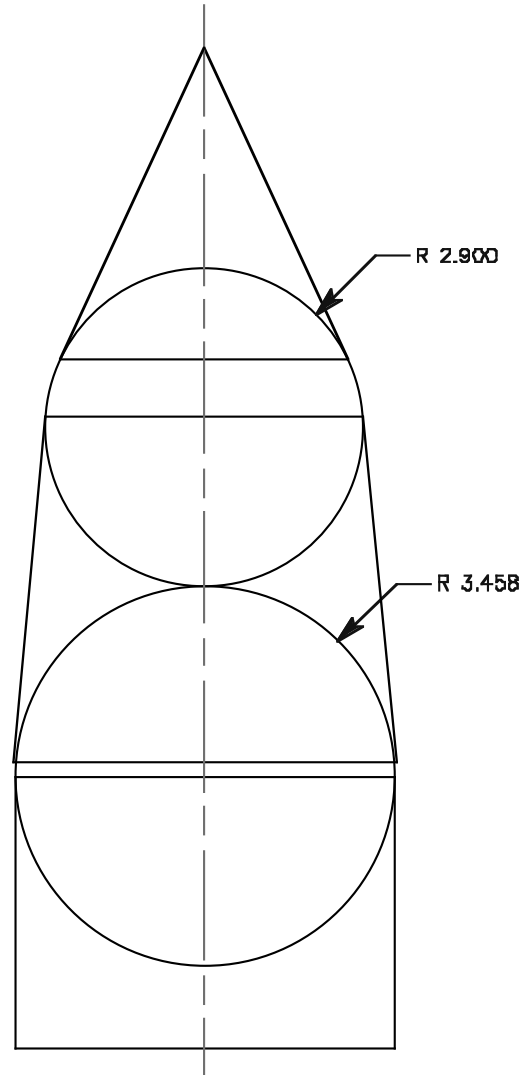

Mass Summary - First Pass

• Initial Inert Mass Estimate	12,240 kg
• LOX Tank	2087 kg
• LH2 Tank	1709 kg
• LOX Insulation	119 kg
• LH2 Insulation	433 kg
• Payload Fairing	688 kg
• Intertank Fairing	1677 kg
• Aft Fairing	1433 kg
• Engines	2236 kg
• Thrust Structure	497 kg
• Gimbals	81 kg
• Avionics	744 kg
• Wiring	840 kg
• Reserve	-
• Total Inert Mass	12,543 kg
• Design Margin	-2.4 %



Modifications for Second Pass

- Keep all initial vehicle sizing parameters constant
- Pick vehicle diameter and make tanks cylindrical to fit
- Redo MER analysis

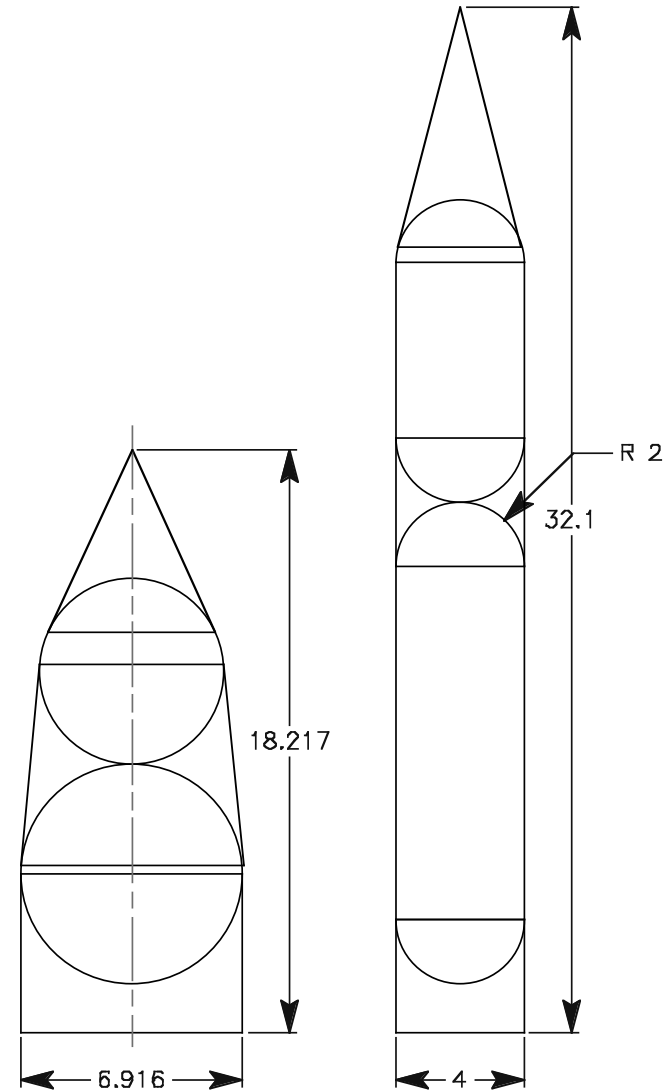

Effect of Vehicle Diameter on Mass Margin

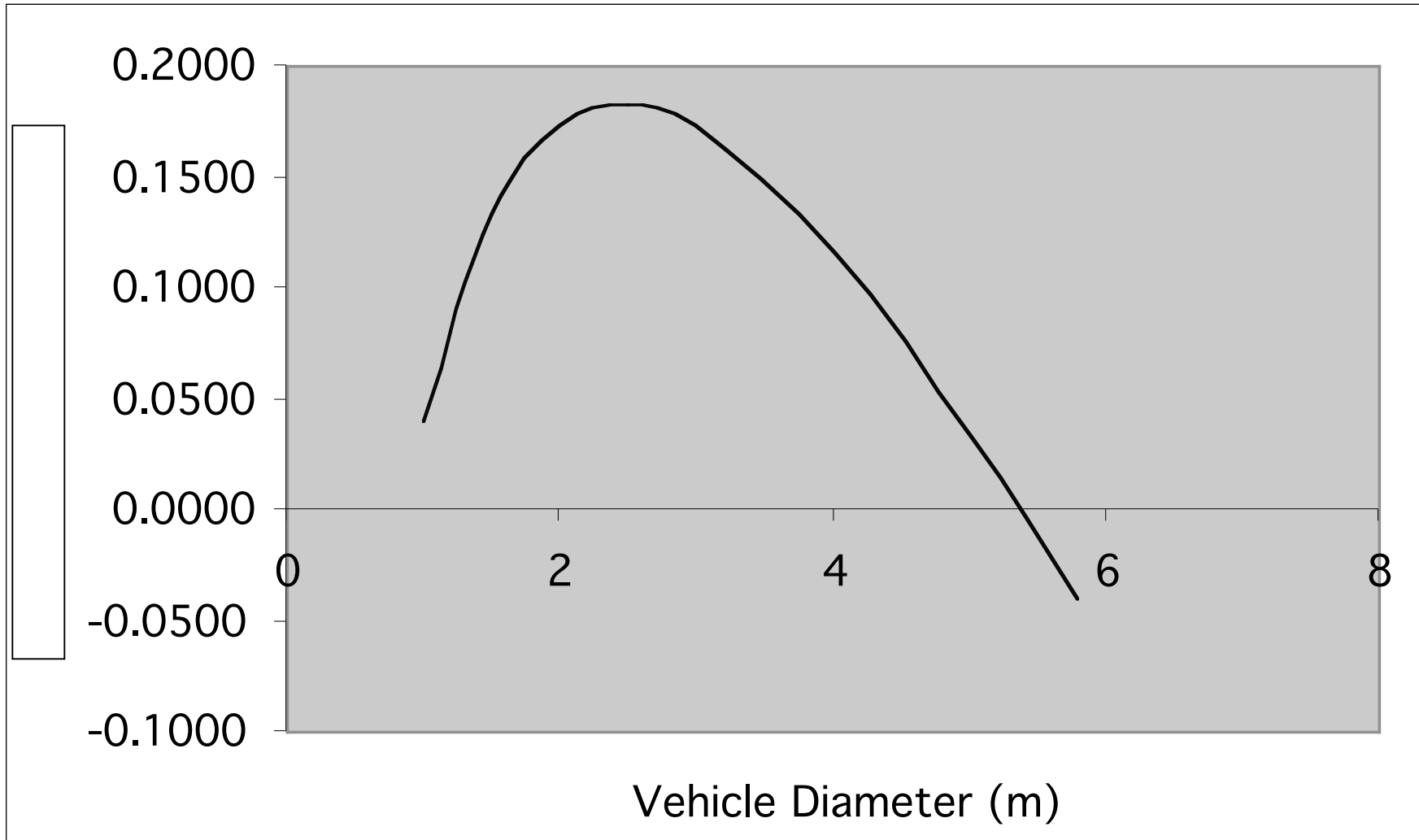

Effect of Mass-Optimal Diameter Choice

- Vehicle has L/D of 25.2 - severe complications from structural dynamics
- Mass margin goes from -2.4% to +18.3%
- Decreased volume for rocket engines in aft fairing
- Infeasible configuration

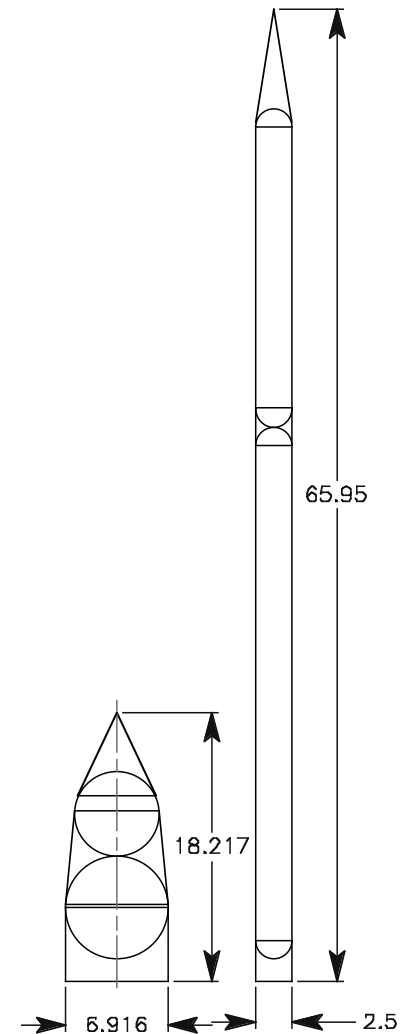

Effect of Diameter on Vehicle L/D

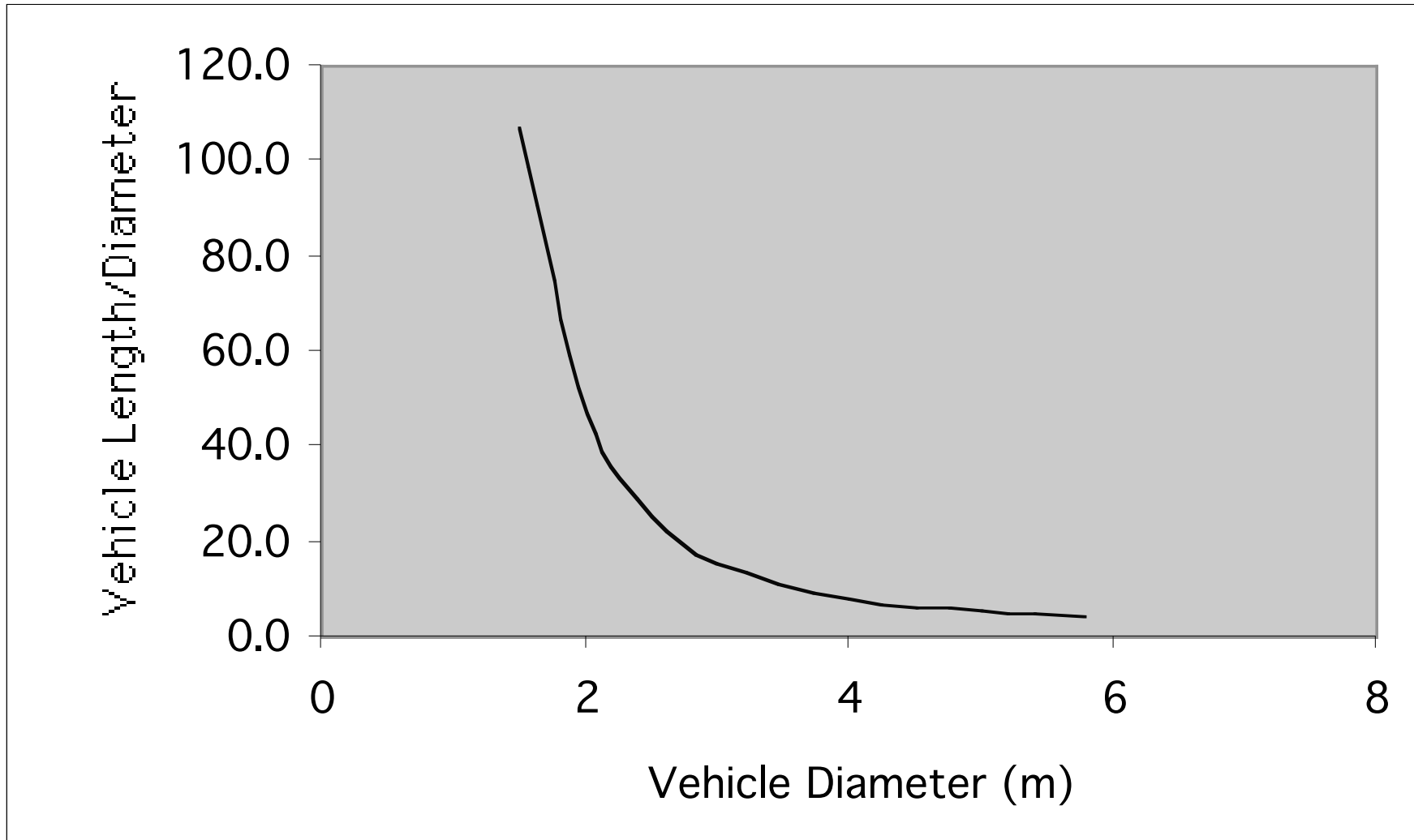

Second Pass Vehicle Configuration

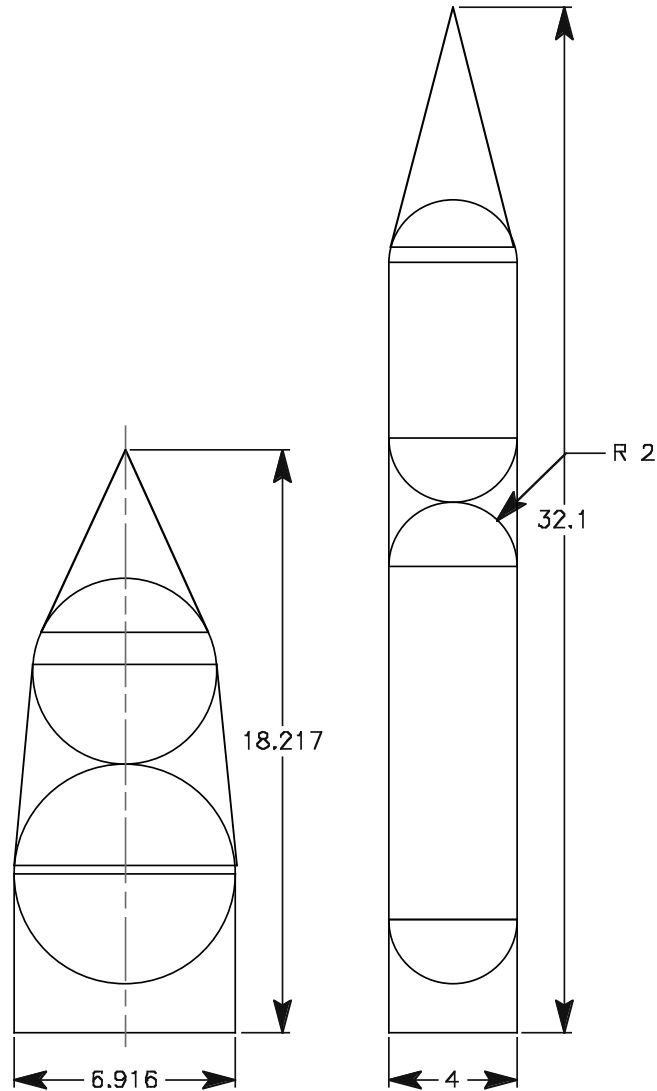

Mass Summary - Second Pass

• Initial Inert Mass Estimate	12,240 kg	12,240 kg
• LOX Tank	2087 kg	2087 kg
• LH2 Tank	1709 kg	1709 kg
• LOX Insulation	119 kg	133 kg
• LH2 Insulation	433 kg	547 kg
• Payload Fairing	688 kg	689 kg
• Intertank Fairing	1677 kg	669 kg
• Aft Fairing	1433 kg	585 kg
• Engines	2236 kg	2236 kg
• Thrust Structure	497 kg	497 kg
• Gimbals	81 kg	81 kg
• Avionics	744 kg	744 kg
• Wiring	840 kg	985 kg
• Reserve	-	-
• Total Inert Mass	12,543 kg	10,960 kg
• Design Margin	-2.4 %	+11.7 %



Modifications for Iteration 3

- Keep 4 m tank diameter
- Change initial assumption of δ iteratively, with resulting changes in m_0 and m_i , to reach 30% mass margin

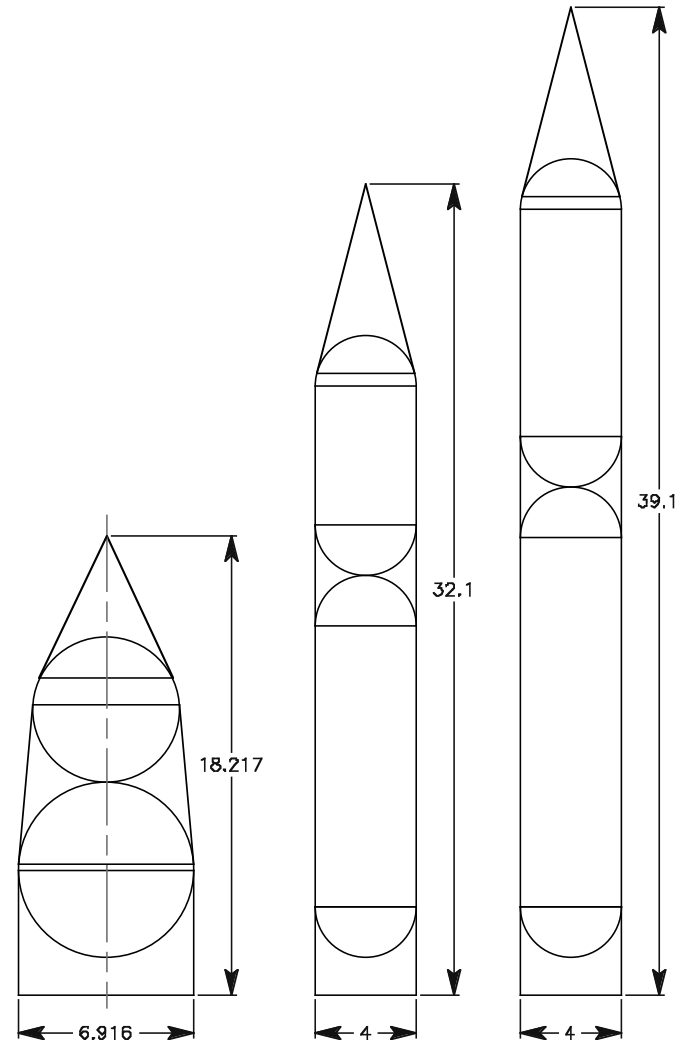

Vehicle-Level Preliminary Design - 3rd Pass

- Single Stage to Orbit (SSTO) vehicle
- 5000 kg payload
- LOX/LH2 propellants

- $I_{sp}=430$ sec

- $\delta=0.08655$

$$r = e^{-\frac{\Delta V}{gI_{sp}}} = 0.1127$$

$$\lambda = r - \delta = 0.0261$$

$$M_0 = \frac{M_L}{\lambda} = 191,300 \text{ kg}$$

$$M_i = \delta M_0 = 16,560 \text{ kg}$$

$$M_p = M_0(1 - r) = 169,800 \text{ kg}$$



Third Pass Vehicle Configuration

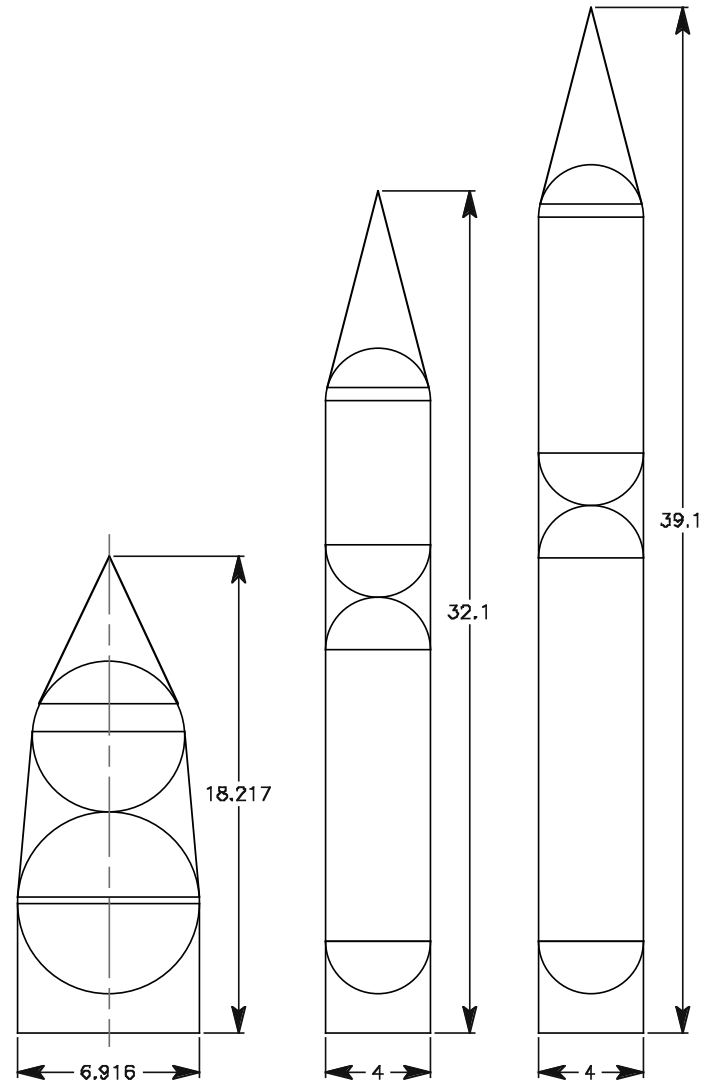

Mass Summary - Third Pass

• Initial Inert Mass Estimate	12,240 kg	12,240 kg	16,560 kg
• LOX Tank	2087 kg	2087 kg	2530 kg
• LH2 Tank	1709 kg	1709 kg	2046 kg
• LOX Insulation	119 kg	133 kg	162 kg
• LH2 Insulation	433 kg	547 kg	672 kg
• Payload Fairing	688 kg	689 kg	689 kg
• Intertank Fairing	1677 kg	669 kg	669 kg
• Aft Fairing	1433 kg	585 kg	585 kg
• Engines	2236 kg	2236 kg	2708 kg
• Thrust Structure	497 kg	497 kg	622 kg
• Gimbals	81 kg	81 kg	100 kg
• Avionics	744 kg	744 kg	807 kg
• Wiring	840 kg	985 kg	1146 kg
• Reserve	-	-	-
• Total Inert Mass	12,543 kg	10,960 kg	12,740 kg
• Design Margin	-2.4 %	+11.7 %	+30 %



Mass Budgeting

	<u>Estimates</u>	<u>Budgeted</u>	<u>Margins</u>
• Initial Inert Mass Estimate	16,560 kg	16,560 kg	3826 kg
• LOX Tank	2530 kg	2910 kg	380 kg
• LH2 Tank	2046 kg	2354 kg	307 kg
• LOX Insulation	162 kg	187 kg	24 kg
• LH2 Insulation	672 kg	773 kg	101 kg
• Payload Fairing	689 kg	793 kg	104 kg
• Intertank Fairing	669 kg	769 kg	100 kg
• Aft Fairing	585 kg	673 kg	88 kg
• Engines	2708 kg	3115 kg	407 kg
• Thrust Structure	622 kg	715 kg	93 kg
• Gimbals	100 kg	115 kg	15 kg
• Avionics	807 kg	928 kg	121 kg
• Wiring	1146 kg	1318 kg	172 kg
• Reserve	-	1913 kg	1913 kg
• Total Inert Mass	12,740 kg	16,560 kg	

