

Overview of Term Project

- Overview of COTS program
- Review of COTS entries
- List of term project expectations



Overview of COTS

- Commercial Orbital Transportation Systems demonstration program
- Initial award 2006
 - SpaceX
 - Rocketplane Kistler (RpK)
- Modification 2008
 - Dropped RpK for lack of financing (2007)
 - Added Orbital Sciences



Rocketplane Kistler K-1



UNIVERSITY OF
MARYLAND

SpaceX Falcon 9/Dragon

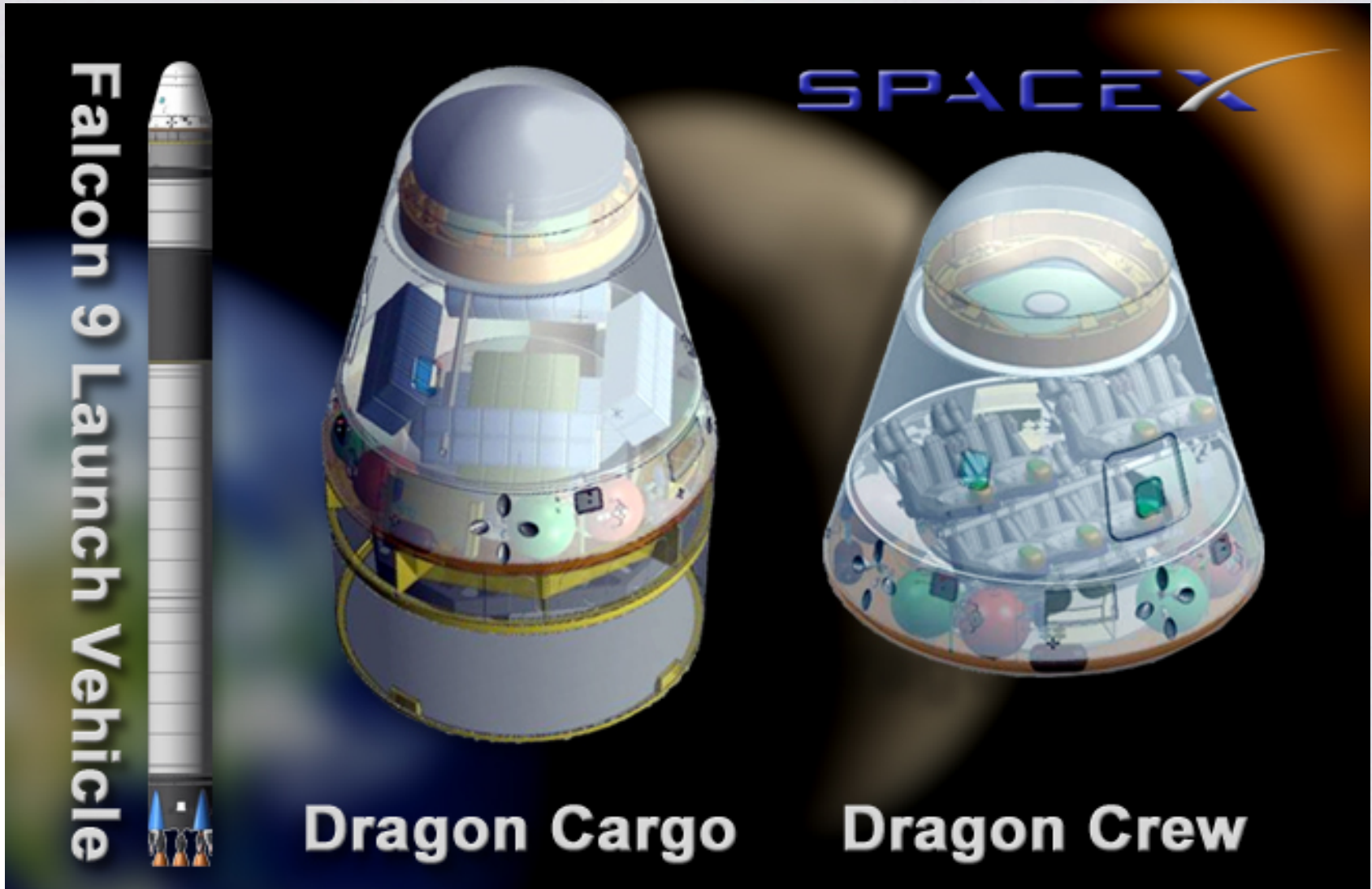

Andrews COTS Proposal

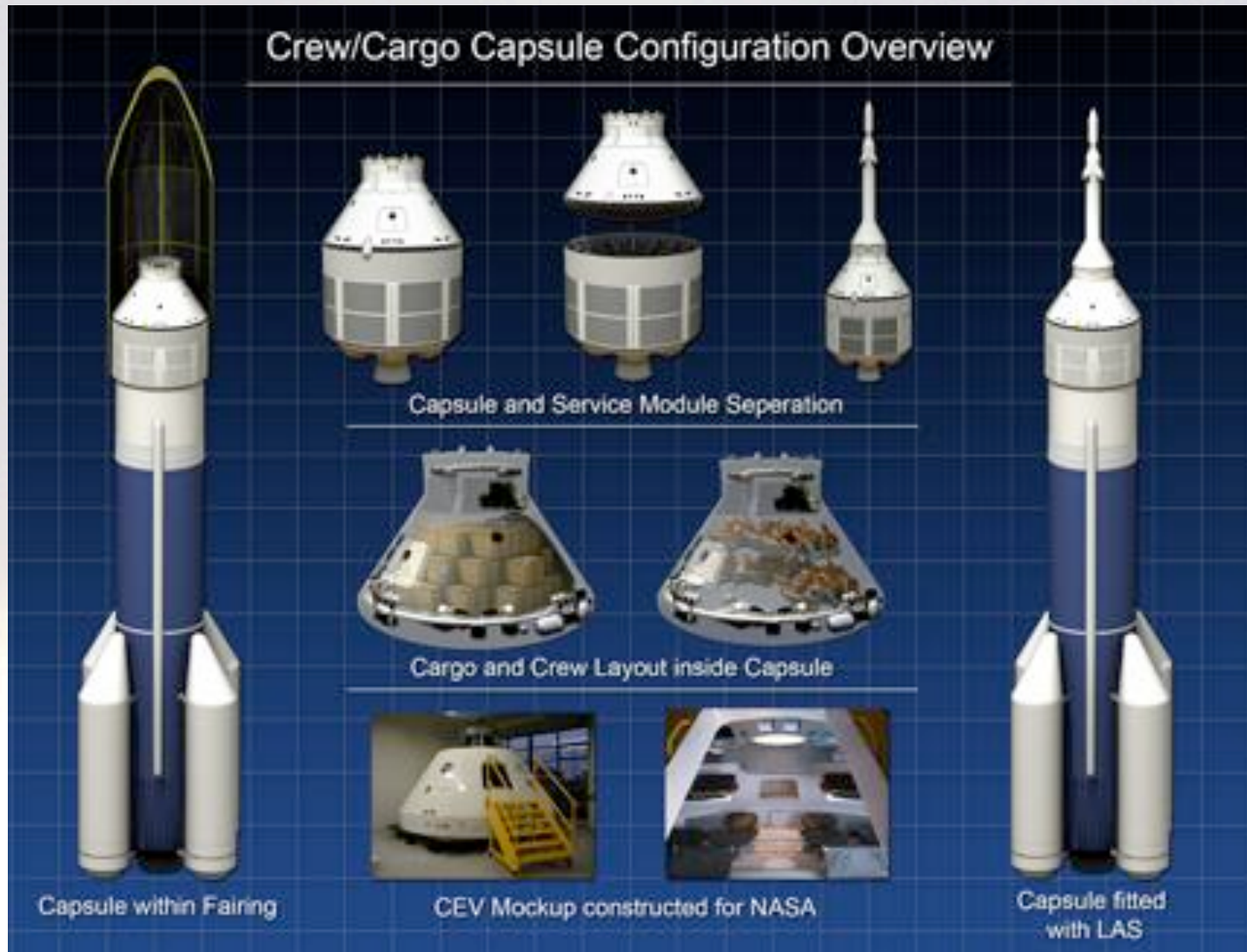

Orbital Sciences Taurus II/Cygnus



UNIVERSITY OF
MARYLAND

Capability Entry Levels

- Capability A: external (unpressurized) cargo delivery and disposal (destructive reentry)
- Capability B: internal (pressurized) cargo delivery and disposal
- Capability C: internal cargo delivery and (intact) return
- Capability D: Crew transportation (proposals accepted only as an option to Capability C proposal)



Category C Details

- Deliver up to 7000 kg/yr of internal cargo
- Deliver up to 1100 kg/yr of water
- Deliver up to 300 kg/yr of atmospheric gas
 - Delivered as high pressure gases (O₂ and N₂)
 - Assume pressure bottles are twice the mass of contained gases (=900 kg/yr total for this task)
- 2-8 flights/year (optimized by bidder)
- Mission reliability 95% at 50% confidence
- Use existing ISS docking interfaces



ISS Standard Pressurized Interfaces

- Common Berthing Mechanism (CBM)
 - Used for connection of pressurized modules
 - Available for berthing only
- Androgynous Peripheral Attach System (APAS)
 - Used for docking shuttle
- Russian Probe-Drogue System
 - Used by Soyuz and ATV
- Low Impact Docking System
 - Still under development



CBM (on ISS Airlock Module)



APAS Mechanism

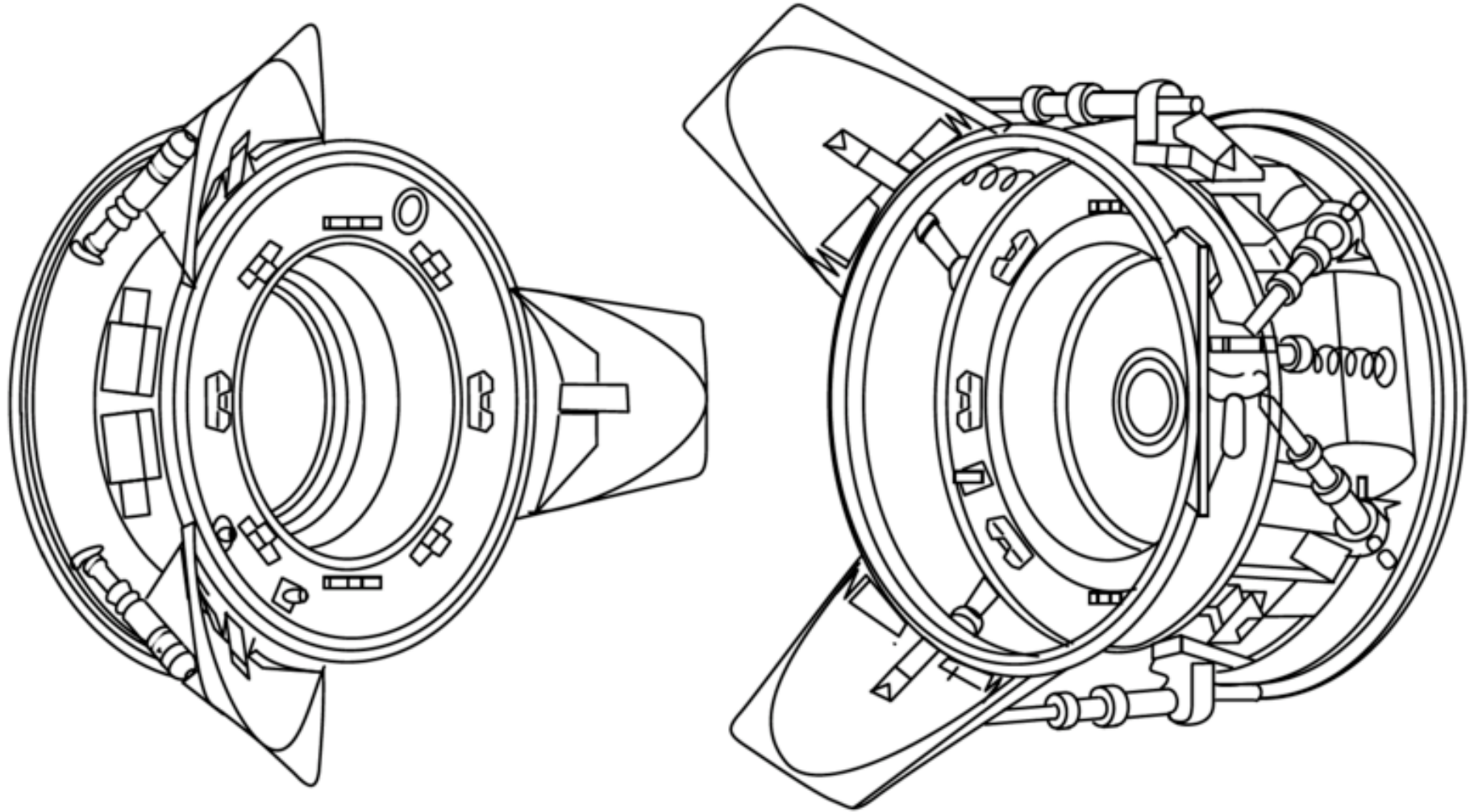

LIDS Mechanism



COTS Programmatic

- Successful demonstration flight within 54 months of program start
- Total funding available from NASA ~\$250M
- Cap on annual resupply costs to NASA of \$600M



Term Project Tasks (1)

- Design launch vehicle and cargo spacecraft/entry vehicle for COTS Category C
- Using values and techniques from class, perform trade studies of critical design parameters, e.g.
 - Number of stages
 - Propellant choices
 - Vehicle sizing
 - Expendable vs. reusable
 - Entry lift/drag ratio



Term Project Tasks (2)

- Calculate launch and entry trajectories
- Use NASA SLVCM cost algorithms to estimate nonrecurring and recurring costs
- Estimate life cycle costs, including commercial-level return on investment, and using NASA COTS funding as early revenue
- Calculate required reliabilities to create a resilient cargo transport system
- Targets of opportunity, e.g. comparison to established NASA COTS contractor



Term Project Reporting

- Prepare a PowerPoint (or equivalent) presentation
 - Listing assumptions
 - Summarizing analyses
 - Presenting results
- Pay attention to details of presentation and formatting
- No oral presentations
- Slide package due electronically by last day of class* (*your mileage may vary...)



Last Word

- Term project will be in lieu of final exam...

