

Reliability, Redundancy, and Resiliency

- Review of probability theory
- Component reliability
- Confidence
- Redundancy
- Reliability diagrams
- Intercorrelated Failures
- System resiliency
- Resiliency in fixed fleets

© 2012 David L. Akin - All rights reserved
<http://spacecraft.ssl.umd.edu>



UNIVERSITY OF
MARYLAND

Reliability, Redundancy, and Resiliency
ENAE 791 - Launch and Entry Vehicle Design

Review of Probability

- Probability that A occurs

$$0 \leq P(A) \leq 1$$

- Probability that A does not occur

$$P(\bar{A})$$

- Sum of all probable outcomes

$$P(A) + P(\bar{A}) = 1$$



Review of Probability

- Probability of both A and B occurring

$$P(A) \cap P(B) = P(A)P(B)$$

- Probability of either A or B occurring

$$P(A) \cup P(B) = 1 - P(\bar{A})P(\bar{B})$$

$$= 1 - [1 - P(A)][1 - P(B)]$$

$$= P(A) + P(B) - P(A)P(B)$$



Baseline Results

Results in the reliability / safety space

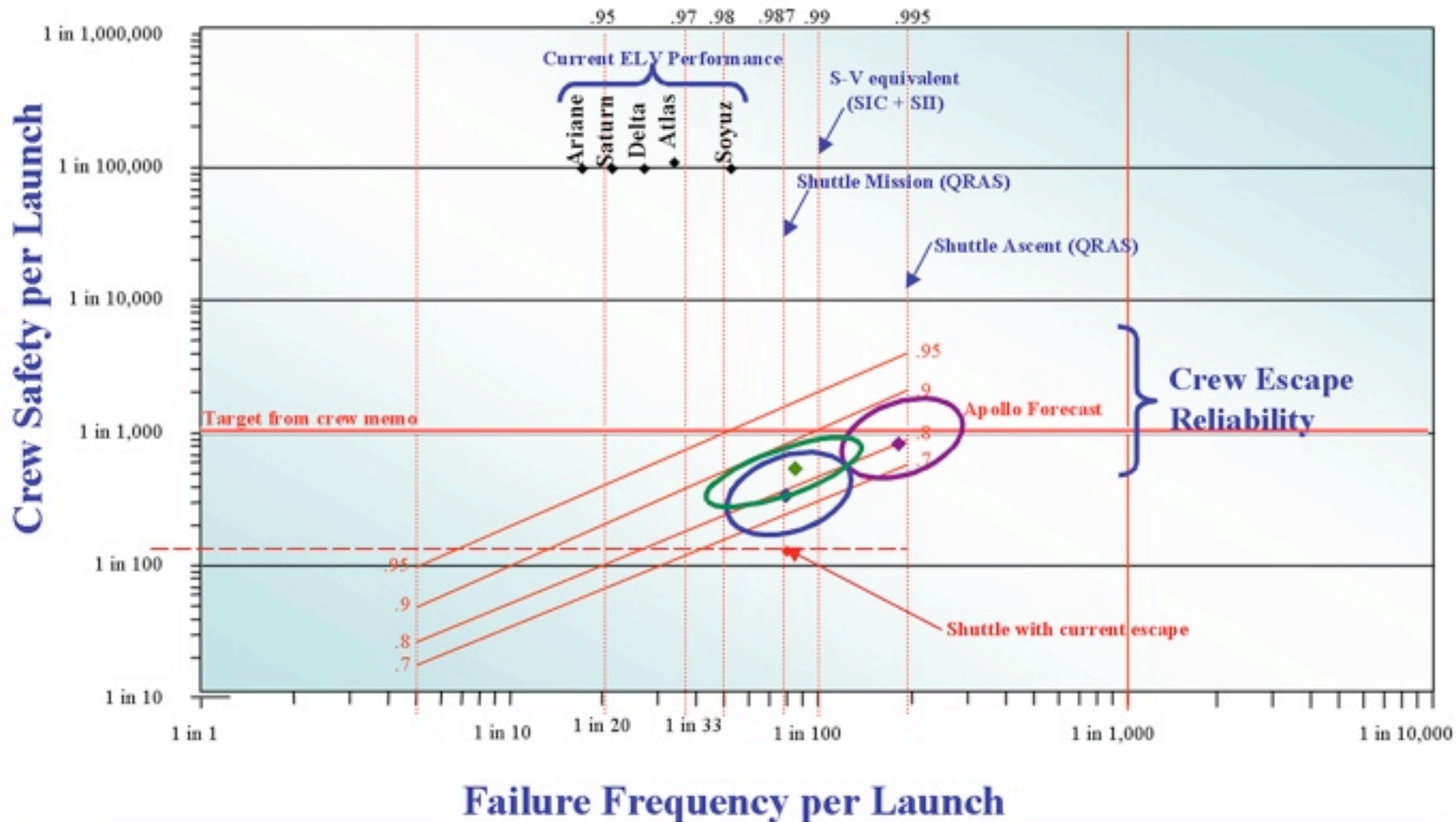

Simple Overview of Abort Reliability

$$P_{survival} = P_{launch} \cup P_{abort}$$

$$P_{survival} = 1 - (\bar{P}_{launch} \cap \bar{P}_{abort})$$

$$P_{survival} = 1 - [(1 - P_{launch})(1 - P_{abort})]$$

$$P_{abort} = 1 - \frac{1 - P_{survival}}{1 - P_{launch}}$$

$$P_{survival} = 0.999; P_{launch} = 0.97$$

$$P_{abort} = 1 - \frac{1 - 0.999}{1 - 0.97} = 0.9667$$



Expected Value Theory

- Probability of an outcome does not determine value of the outcome
- Combine probabilities and values to determine expected value of outcome

$$EV = P(A)U(A) + P(\bar{A})U(\bar{A})$$



Expected Value Example

- Maryland State Lottery - pick six numbers out of 49 (any order)

$$P(\text{win}) = 1 / \frac{49!}{6!43!} = 1/13,983,816$$

- Assume \$10,000,000 jackpot

$$EV = (7.151 \times 10^{-8})(10^7) + (1)(-1) = -\$0.39$$



Utility Theory

- Numerical rating from expected value calculations does not fully quantify utility
- Lottery example previously: utility of (highly unlikely) win exceeds negative utility of small investment: *risk proverse*
- Imagine lottery where \$1000 buys 1:500 chance at \$1M -
$$EV = (.998)(-\$1000) + (.002)(\$999M) = \$1000$$
risk adverse



Component Reliability

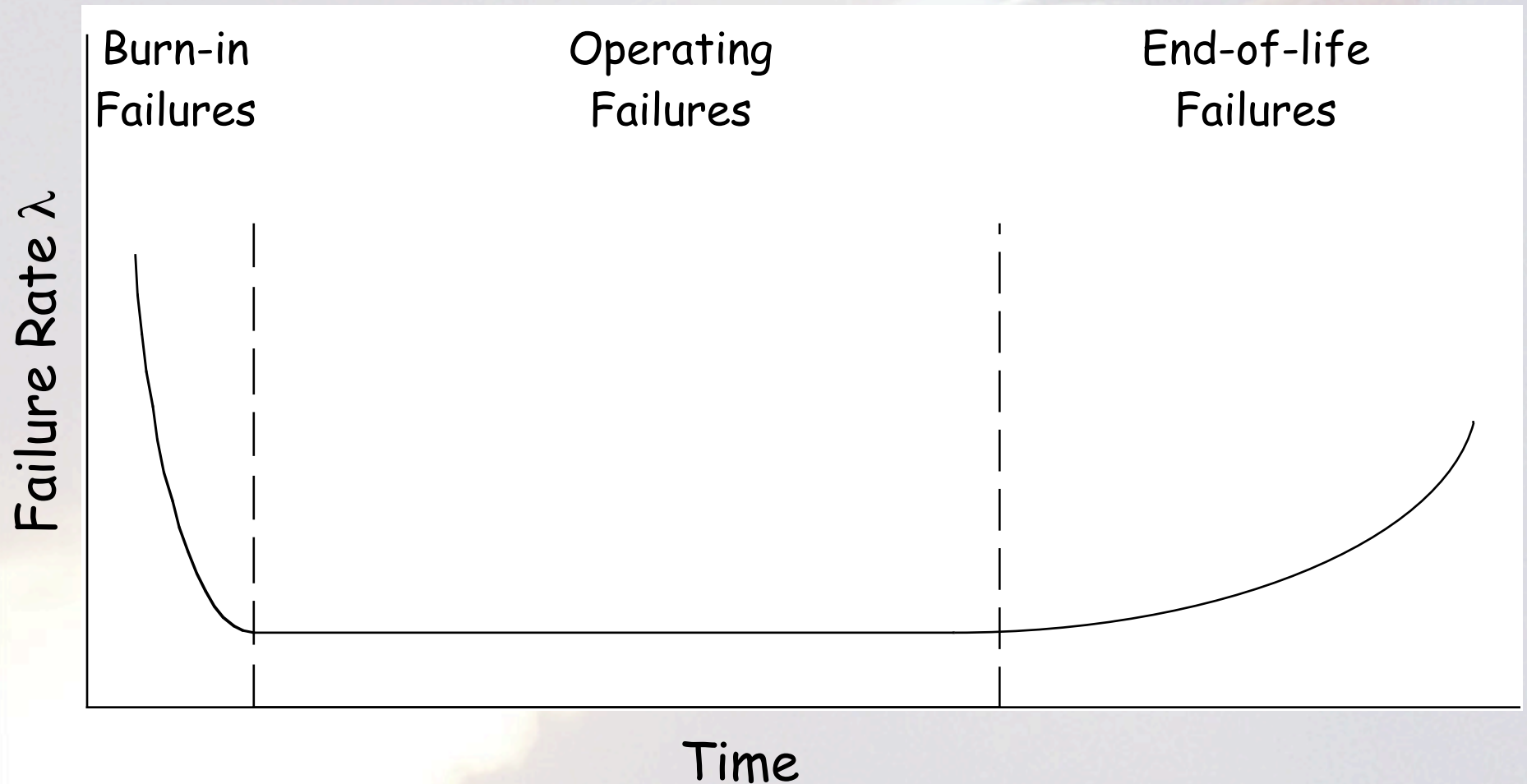

Reliability Analysis

- Failure rate is defined as fraction of currently operating units failing per unit time

$$\lambda(t) = -\frac{1}{R(t)} \frac{d}{dt} R(t)$$

- The trend of operating units with time is then

$$\int_0^t \lambda(\tau) d\tau = -\int_1^{R(t)} \frac{dR(\tau)}{R(\tau)}$$



Reliability Analysis (continued)

- Evaluation of the definite integrals gives

$$\int_0^t \lambda(\tau) d\tau = -\ln[R(t)]$$

- Assuming that λ is constant over the operating lifetime,

$$R(t) = \exp\left[-\int_0^t \lambda(\tau) d\tau\right] = e^{-\lambda t}$$

- At $t=1/\lambda$, $1/e$ of the original units are still operating (defined as mean time between failures)



Reliability Analysis (continued)

- Frequently assess component reliability based on reciprocal of failure rate λ :

$$R(t) = e^{-\frac{t}{MTBF}}$$

where MTBF=mean time between failures

- For a mission duration of N hours, estimate of component reliability becomes

$$R(\text{mission}) = e^{-\frac{N}{MTBF}}$$



Verifying a Reliability Estimate

- Given a unit reliability of R , what is the probability P of testing it 20 times without a failure?
- What is the probability Q that you will see one or more failures?
 - $R=.99$ - $P=.8179$ - $Q=.1821$
 - $R=.95$ - $P=.3584$ - $Q=.6416$
 - $R=.90$ - $P=.1216$ - $Q=.8784$



Confidence

- The confidence C in a test result is equal to the probability that you should have seen worse results than you did

$$P(\text{observed and better outcomes}) + C = 1$$



Example of Confidence

- 100 vehicle flights with 1 failure
- Assume a reliability value of R

$$R^{100} + 100R^{99}(1 - R) + C = 1$$

- Trade off reliability with confidence values

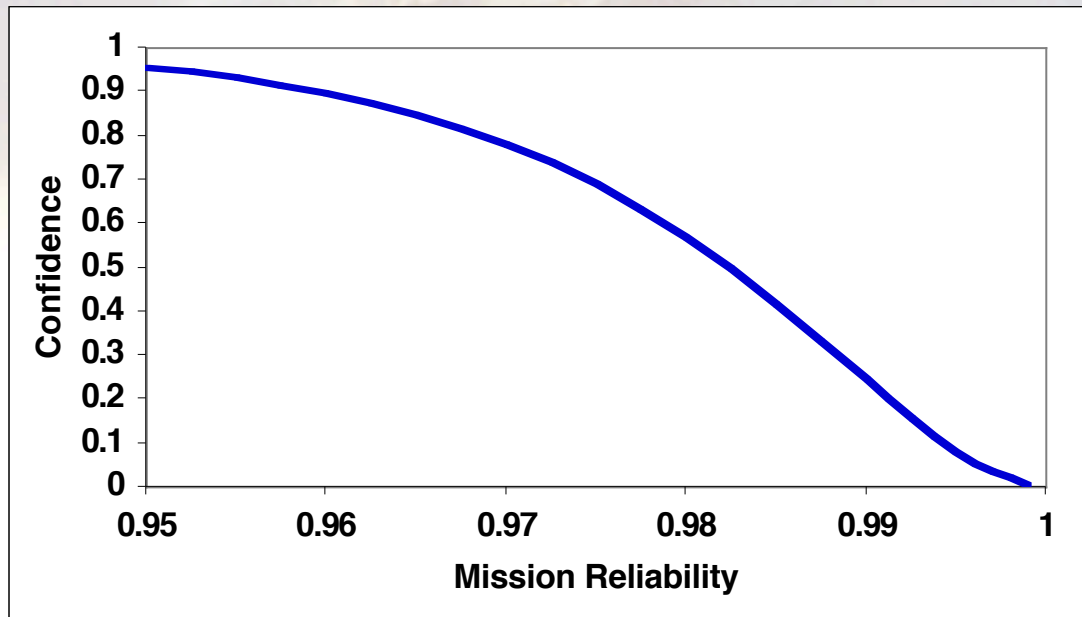

Definition of Redundancy

- Probability of k out of n units working =
(number of combinations of k out of n) x
 $P(k \text{ units work}) \times P(n-k \text{ units fail})$

$$P \binom{k}{n} = \frac{n!}{k!(n-k)!} P^k (1-P)^{n-k}$$



Redundancy Example

3 parallel computers, each has reliability of 95%:

- Probability all three work

$$P(3) = P^3 = (.95)^3 = .8574$$

- Probability exactly two work

$$P(2) = 3P^2(1 - P) = 3(.95)^2(.05) = .1354$$

- Probability exactly one works

$$P(1) = 3P(1 - P)^2 = 3(.95)(.05)^2 = .0071$$

- Probability that none work

$$P(0) = (1 - P)^3 = (.05)^3 = .0001$$



Redundancy Example

3 parallel computers, each has reliability of 95%:

- Probability all three work

$$P(3) = .8574$$

- Probability at least two work

$$P(3) + P(2) = .8574 + .1354 = .9928$$

- Probability at least one works

$$P(3) + P(2) + P(1) = .9928 + .0071 = .9999$$

- Probability that none work

$$P(0) = (1 - P)^3 = (.05)^3 = .0001$$



Reliability Diagrams

- Example of Apollo Lunar Module ascent engine
- Three valves in each of oxidizer and fuel lines
- One in each set of three must work
- $R_v = 0.9 \rightarrow R_{system} = .998$

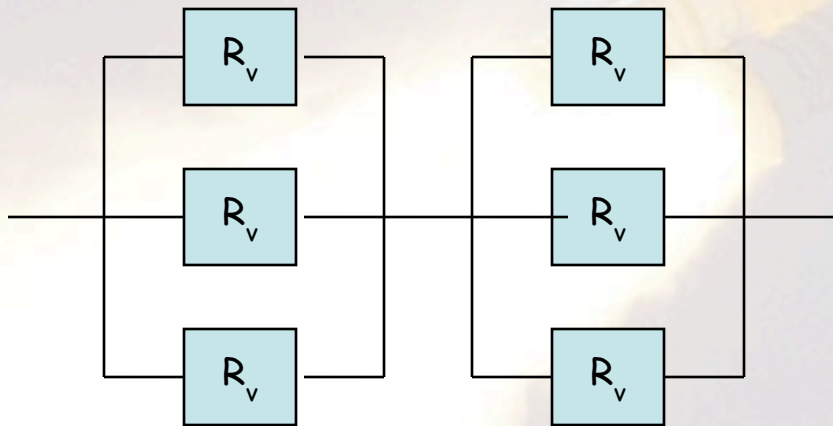

$$R_{system} = \left[1 - (1 - R_v)^3 \right]^2$$



Reliability Diagrams (how not to...)

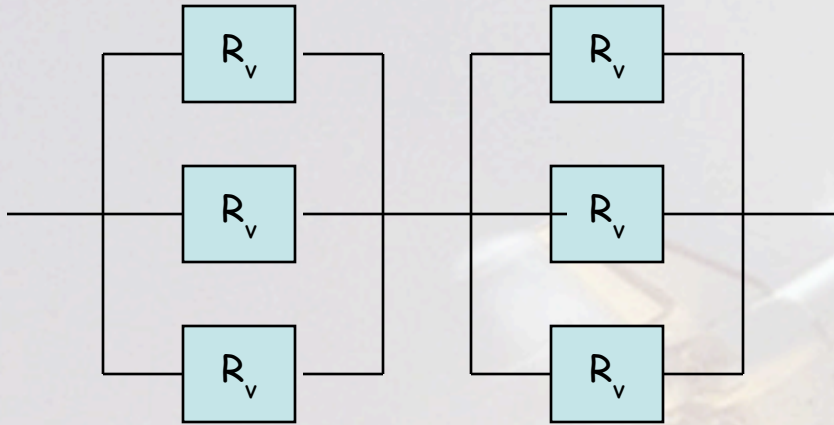

$$R_{system} = \left[1 - (1 - R_v)^3 \right]^2$$

$$R_v = 0.9 \rightarrow R_{system} = .998$$

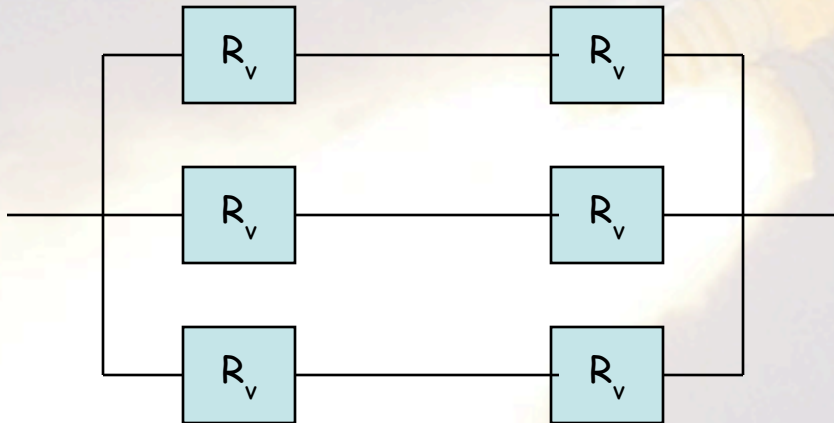

$$R_{system} = \left[1 - (1 - R_v^2)^3 \right]$$

$$R_v = 0.9 \rightarrow R_{system} = .993$$





Earth Departure Configuration

8 launches and 7 dockings required to start mission

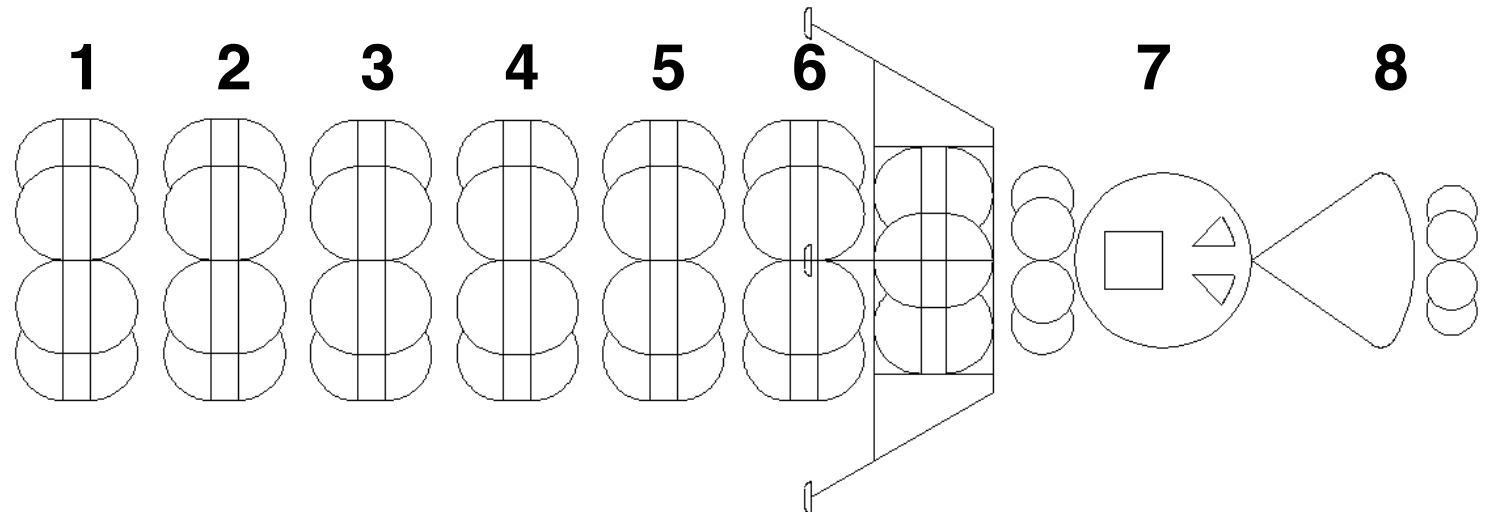

Assume $P_{\text{launch}}=0.97$ and $P_{\text{dock}}=0.99$

$$P_{\text{no failures}} = P_{\text{launch}}^8 P_{\text{dock}}^7 = 0.73$$

$$P_{\text{all boost modules}} = P_{\text{launch}}^6 P_{\text{dock}}^5 = 0.792$$

$$P_{\text{all boost modules}} = P_{\text{no failures}} + P_{\text{1 failure}} =$$

$$0.792 + 6(1 - P_{\text{launch}})P_{\text{launch}}^6 P_{\text{dock}}^5 = 0.792 + 0.143 = 0.935$$



Spares - The Big Picture

- Have to get 6 functional boost modules for each of 10 missions
- Have to get functional lunar vehicle and crew module for each mission
- Assume composite reliability =0.97(0.99)
=0.96

$$P(n | n) = p^n$$

$$P(n | n + 1) = n(p^{n-1})(1 - p)(p)$$

$$P(n | n + 2) = \frac{n(n - 1)}{2} (p^{n-2})(1 - p)^2(p)$$

$$P(n | n + m) = \frac{n!}{(n - m)!m!} (p^{n-m})(1 - p)^m(p)$$



Effect of Fleet Spares on Program

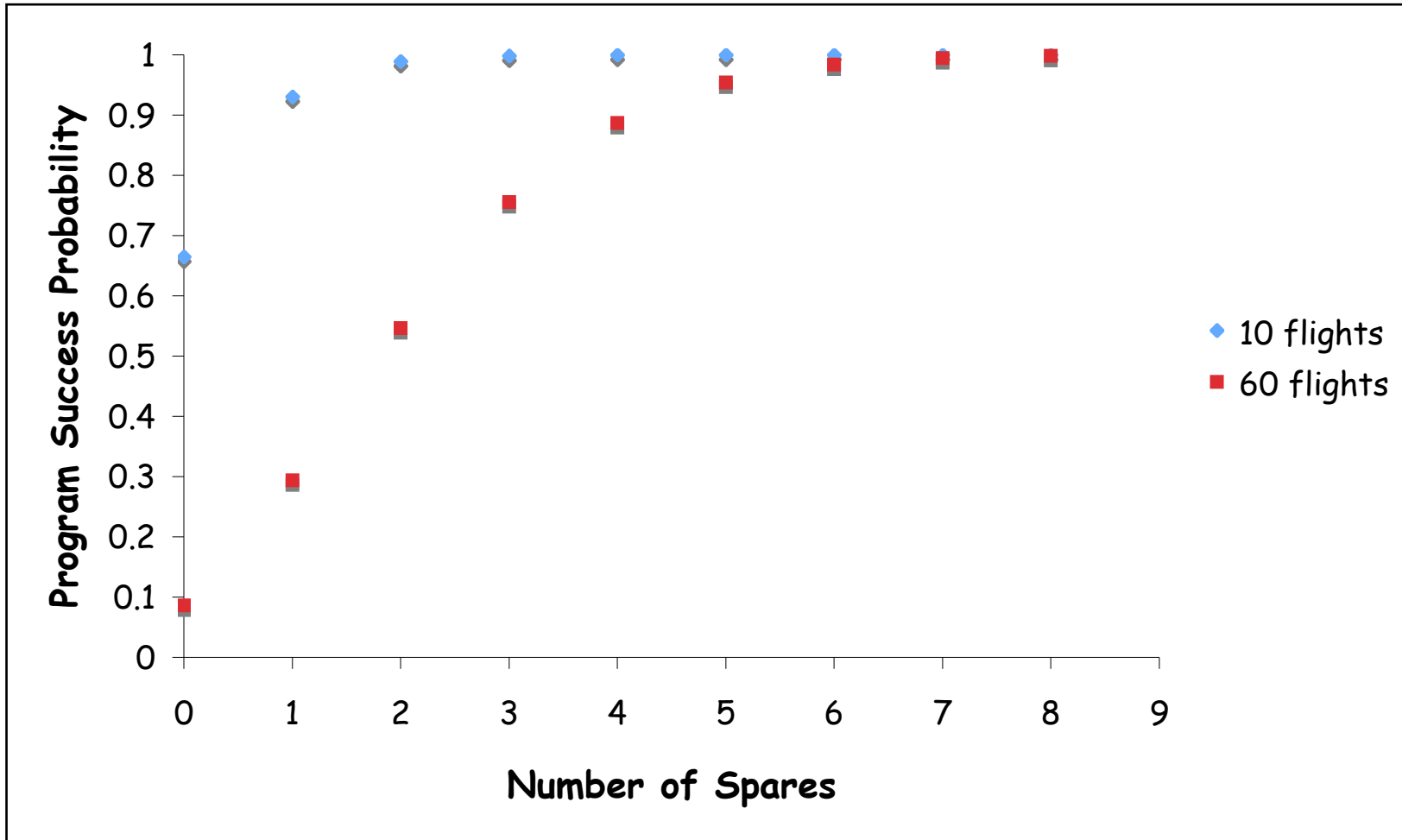



Spares Strategy Selection

- **VSE approach:**
 - 2 launches and 1 dock: $P=(0.97)^2(0.99)=0.931$
 - Program reliability over 10 missions:
 $0.931^{10}=0.492$
- **Goal: meet VSE program reliability**
 - 1 lander and 1 CEV spare - $p=0.9308$ each
 - 2 boost module spares - $p=0.5464$
 - Program reliability: $(0.9308)^2(0.5464)=0.473$
- **Alternate goal: 85% program reliability**
 - 2 lander, 2 CEV, 4 BM spares: $(0.9893)^2(0.8871)=0.868$
 - 1 lander, 1 CEV, 6 BM spares: $(0.9308)^2(0.9838)=0.852$

Intercorrelated Failures

- Some failures in redundant systems are common to all units
 - Software failures
 - “Daisy-chain” failures
 - Design defects
- Following a failure, there is a probability f that the failure causes a total system failure



Intercorrelated Failure Example

3 parallel computers, each has reliability of 95%, and a 30% intercorrelated failure rate:

- Probability all three work

$$P(3) = P^3 = (.95)^3 = .8574$$

- Probability exactly two work (one failure)

$$P(2) = 3P^2(1 - P) = 3(.95)^2(.05) = .1354$$

- Probability the failure is benign (system works)

$$P(2_{safely}) = .7(.1354) = .0948$$

- Probability of intercorrelated failure (system dies)

$$P(2_{system\ failure}) = .3(.1354) = .0406$$



Intercorrelated Failure Example

(continued from previous slide)

- Probability exactly one works (2 failures)

$$P(1) = 3P(1 - P)^2 = 3(.95)(.05)^2 = .0071$$

- Probability that both failures are benign

$$P(1_{safely}) = .7^2 (.0071) = .0035$$

- Probability that a failure is intercorrelated

$$P(1_{system\ failure}) = (1 - .7^2)(.0071) = .0036$$



Redundancy Example with

3 parallel computers, each has reliability of 95%, and a 30% intercorrelated failure rate:

- Probability all three work

$$P(3) = .8574$$

- Probability at least two work

$$= .8574 + .0948 = .9522 \quad (\text{was } .9928)$$

- Probability at least one works

$$= .9522 + .0035 = .9557 \quad (\text{was } .9999)$$



System Reliability with 30% Intercorrelation

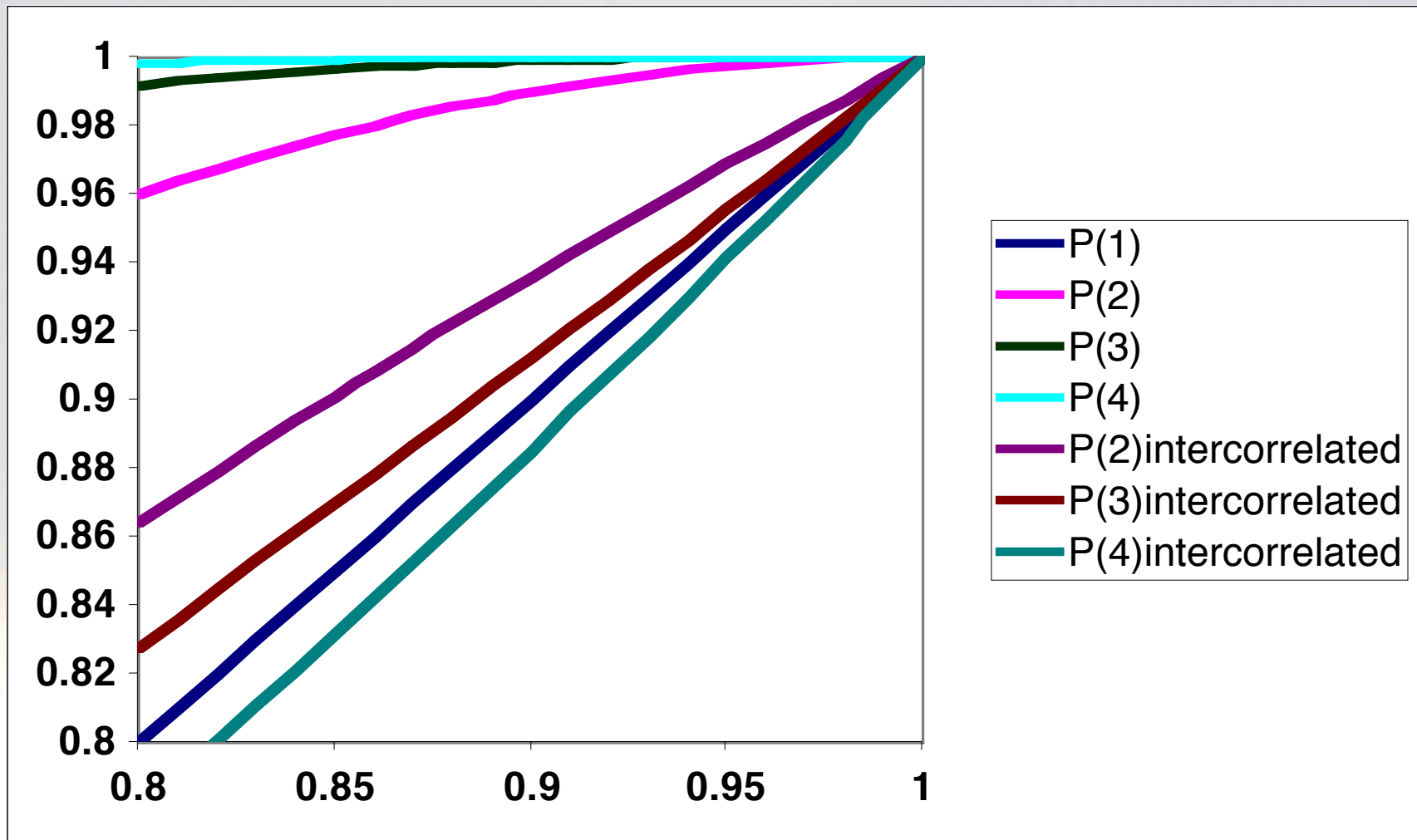

Probabilistic Risk Assessment

- Identification and delineation of the combinations of events that, if they occur, could lead to an accident (or other undesired event)
- Estimation of the chance of occurrence for each combination
- Estimation of the consequences associated with each combination.



U.S. Launch Reliability - 5 yr. rolling avgs.

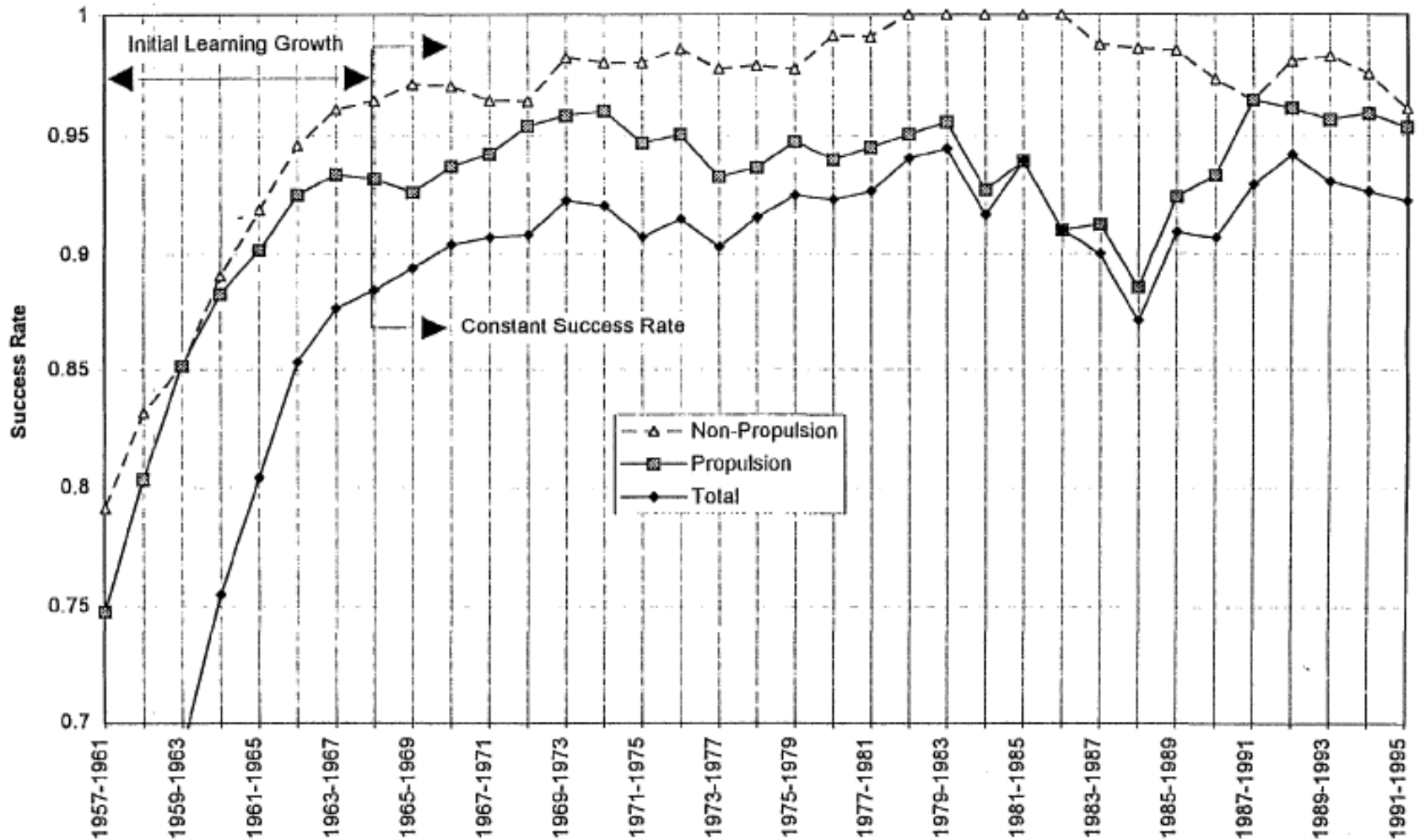

A. G. Allred and D. R. Sauvageau, "Crew Survival and Intact Abort using Solid Rocket Boosters" AIAA 96-3156, July, 1996



LV Subsystem Failures 1984-2004

Failure Type	Failures	Total Events	Individual Percent Failure Rate
Liquid Propulsion (Start)	3	1255	0.239%
Liquid Propulsion (In-flight)	3	1255	0.239%
Total Liquid Failure	6	1255	0.478%
Solid Propulsion (Shell)	4	1831 (all solids)	0.218%
Solid Propulsion (TVC)	3	571 (TVC only)	0.525%
Solid Propulsion with TVC (TVC and Shell Failure Modes)	--	--	0.743%
Stage, Booster, and Payload Separations	6	2577	0.233%
Fairing Separation	1	357	0.280%
Small Solid Booster Separations	1*	1165	0.086%
Electrical	2	470	0.426%
Avionics	2	470	0.426%
Other	1	470	0.213%

*Did not result in total mission loss.

Futron Corporation, "Design Reliability Comparison for SpaceX Falcon Vehicles" Nov. 2004



Expected Failure Rates from Prop/Sep

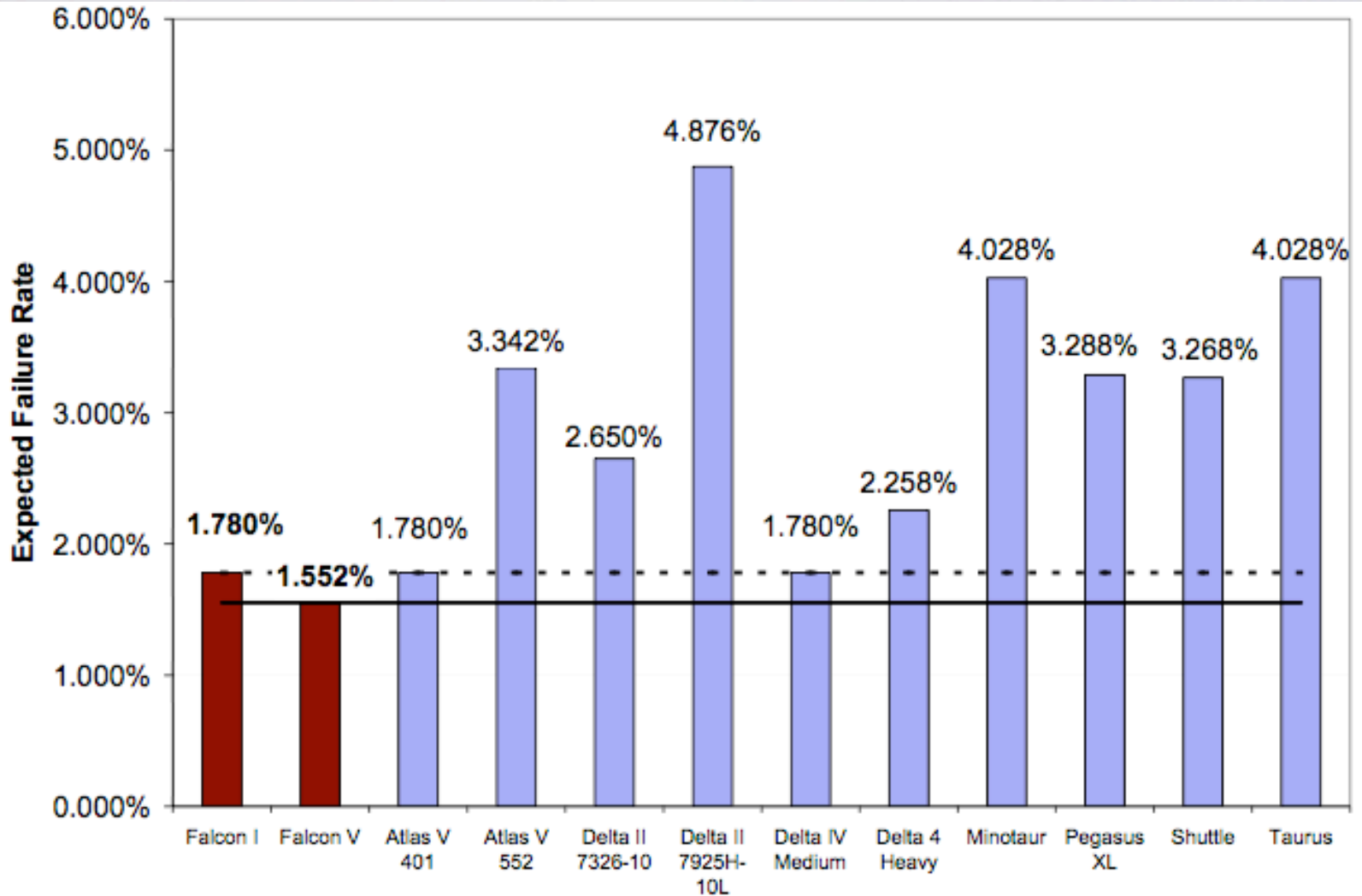

Futron Corporation, "Design Reliability Comparison for SpaceX Falcon Vehicles" Nov. 2004



UNIVERSITY OF
MARYLAND

Concept of System Resiliency

- Initial flight schedule



- Hiatus period following a failure

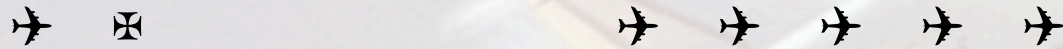

- Backlog of payloads not flown in hiatus

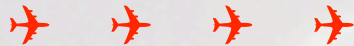

- Surge to fly off backlog



- Resilient if backlog is cleared before next failure occurs (on average)



Resiliency Variables

r - nominal flight rate, flts/yr

d - down time following failure (yrs)

k - fraction of flights in backlog retained

S - surge flight rate/nominal flight rate

m - average/expected flights between failures

rd - number of missed flights

krd - number of flights in backlog

$(S-1)r$ - backlog flight rate



Definition of Resiliency

$$\frac{Srkd}{S-1} \leq m$$

- Example for Delta launch vehicle
- $r = 12$ flts/yr
- $d = 0.5$ yrs
- $k = 0.8$
- $S = 1.5$
- $m = 30$
- $Srkd/(S-1) = 14.4 < 30$ - system is resilient!



Shuttle Resiliency (post-*Challenger*)

$$r = 9 \text{ flts/yr}$$

$$d = 2.5 \text{ yrs}$$

$$k = 0.8$$

$$S = .67 \text{ (6 flts/yr)}$$

$$m = 25$$

- ✓ System has negative surge capacity due to reduction in fleet size - cannot **ever** recover from hiatus without more extreme measures



Modified Resiliency

k' - retention rate of all future payloads
($k' \leq S$ for $S < 1$)

- New governing equation for resiliency:

$$\frac{Srk'd}{S - k'} \leq m$$

- Implication for shuttle case:
✓ $k < .417$ to achieve modified resiliency



Shuttle Resiliency (post-*Columbia*)

- $r = 5$ flts/yr
- $d = 2$ yrs
- $S = .8$ (4 flts/yr)
- $m = 56$ (average missions/failure)
- Modified resiliency requires $k' \leq 0.7$ for all future payloads

