

Structural Design Practices

- Payload interfaces to launch vehicles
- Examples of structural design approaches from past space vehicle structural designs

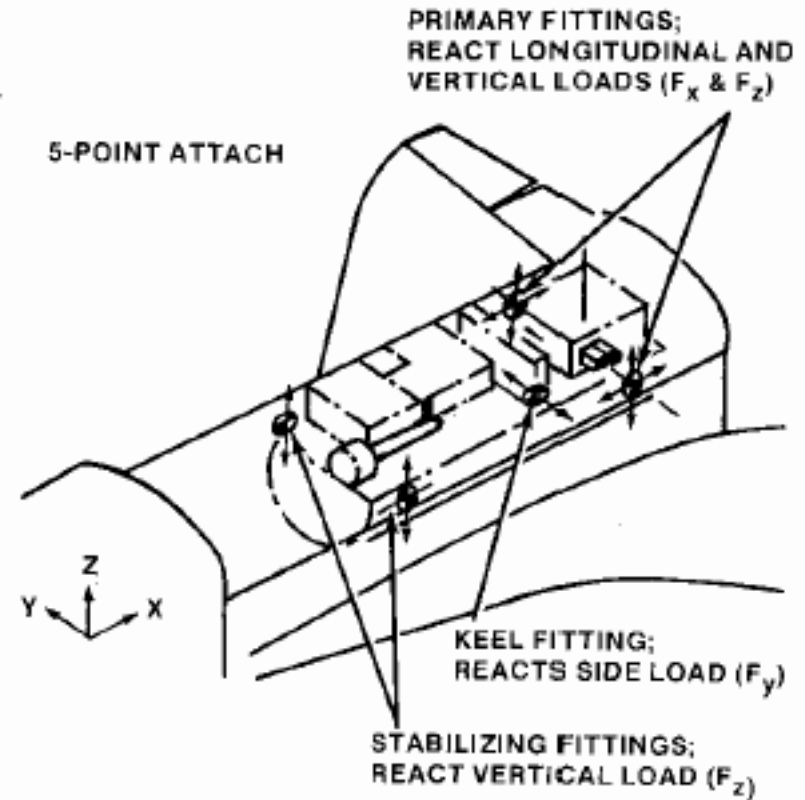

Shuttle Payload Restraint Configurations

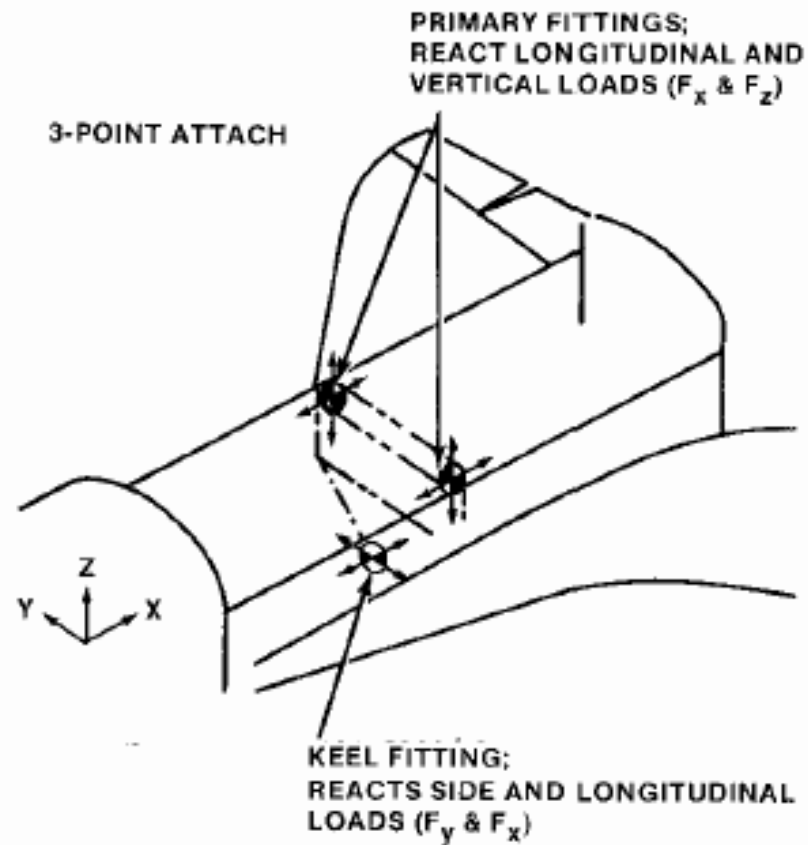

Orbiter Active Latches

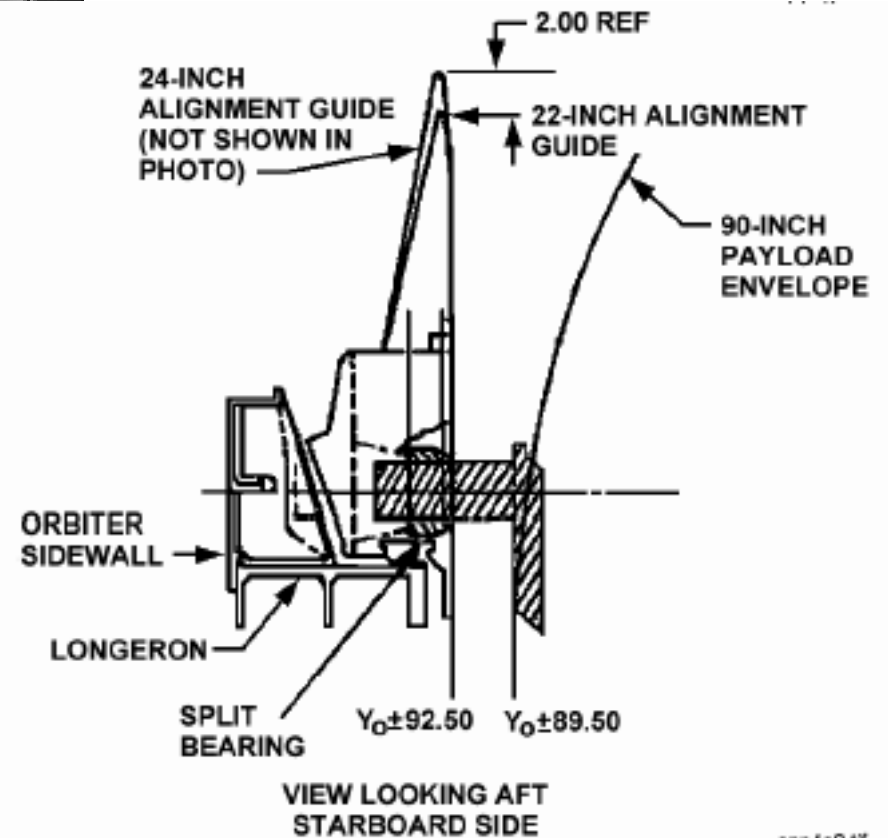
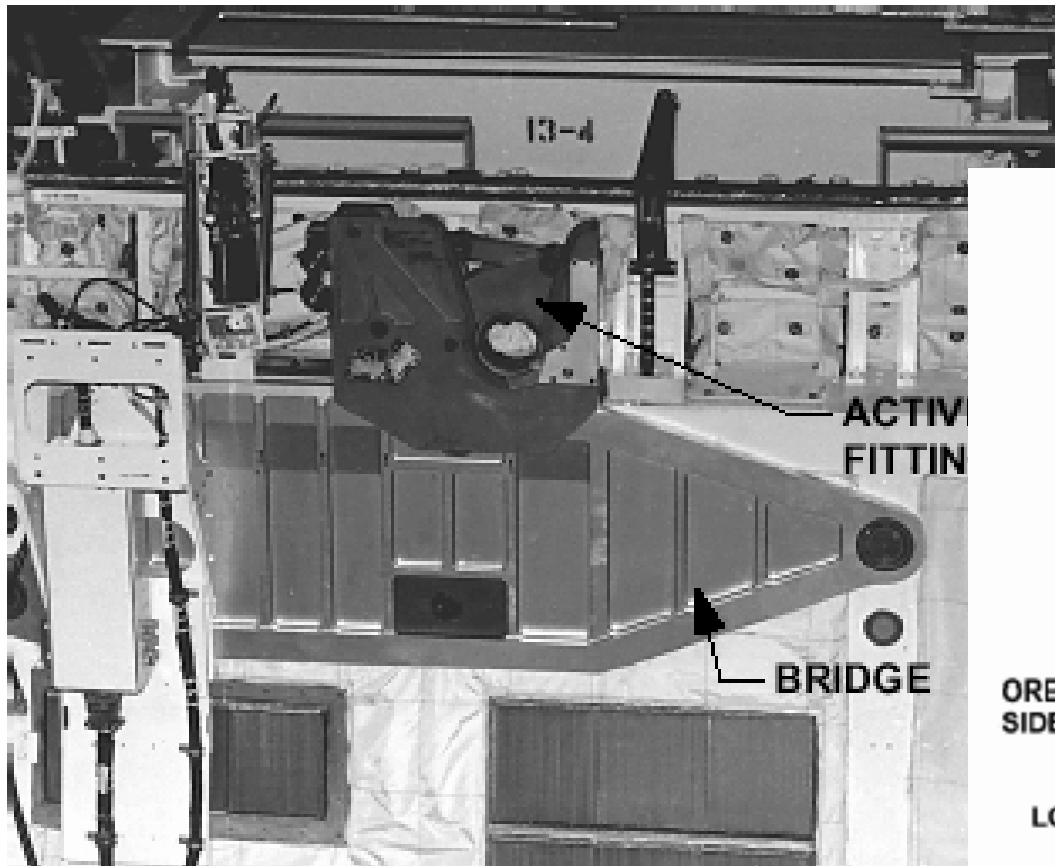

app4g8.tif



UNIVERSITY OF
MARYLAND

Structural Practices
Principles of Space Systems Design

Orbiter Passive Latches

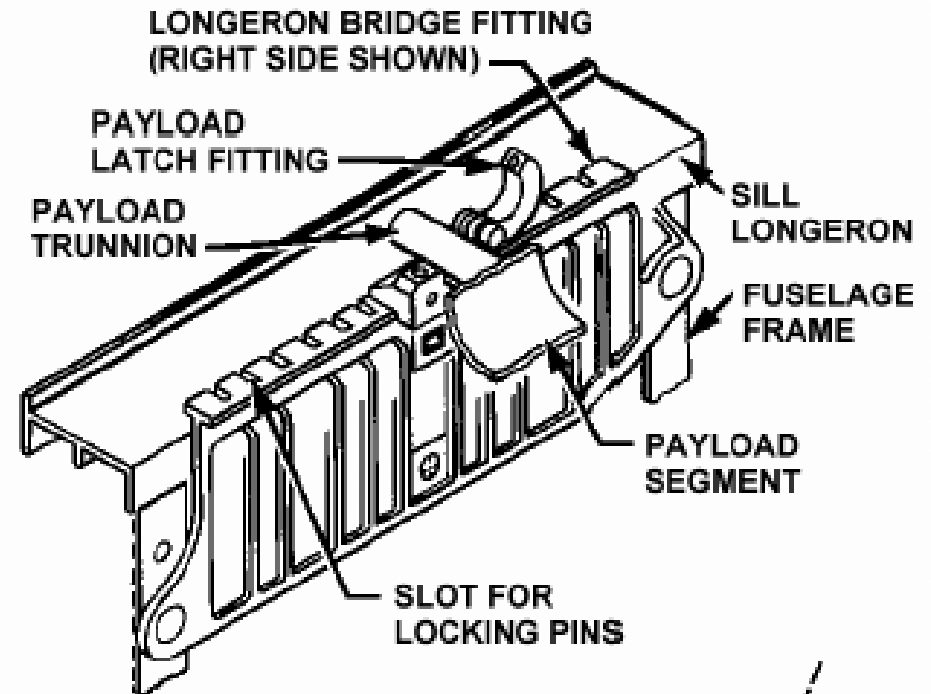
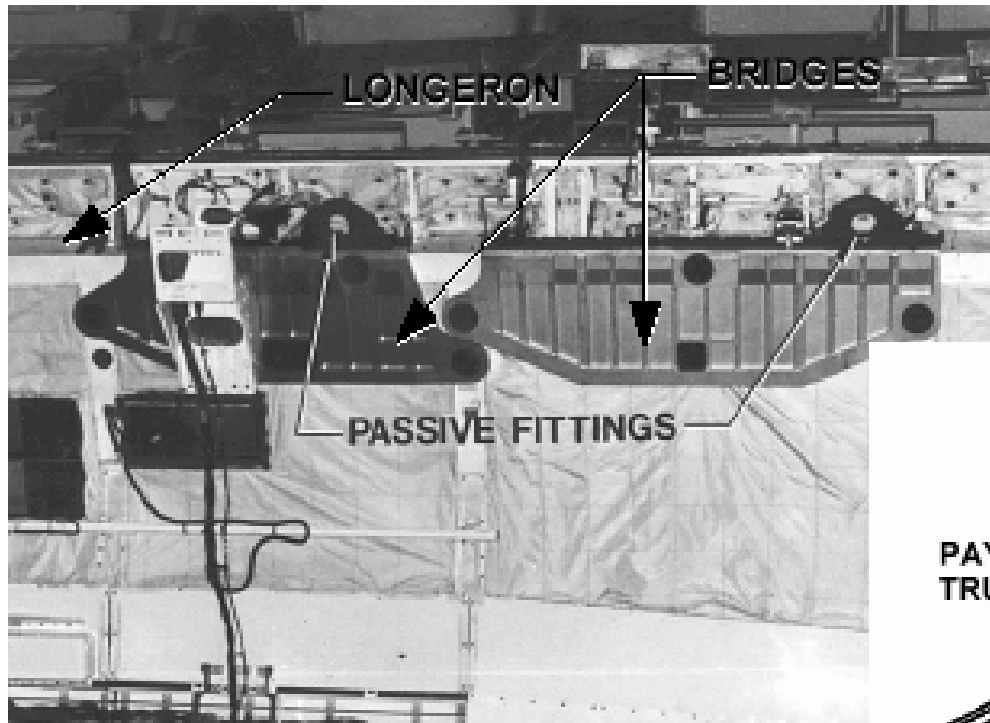

Atlas V Payload Fairing Configuration

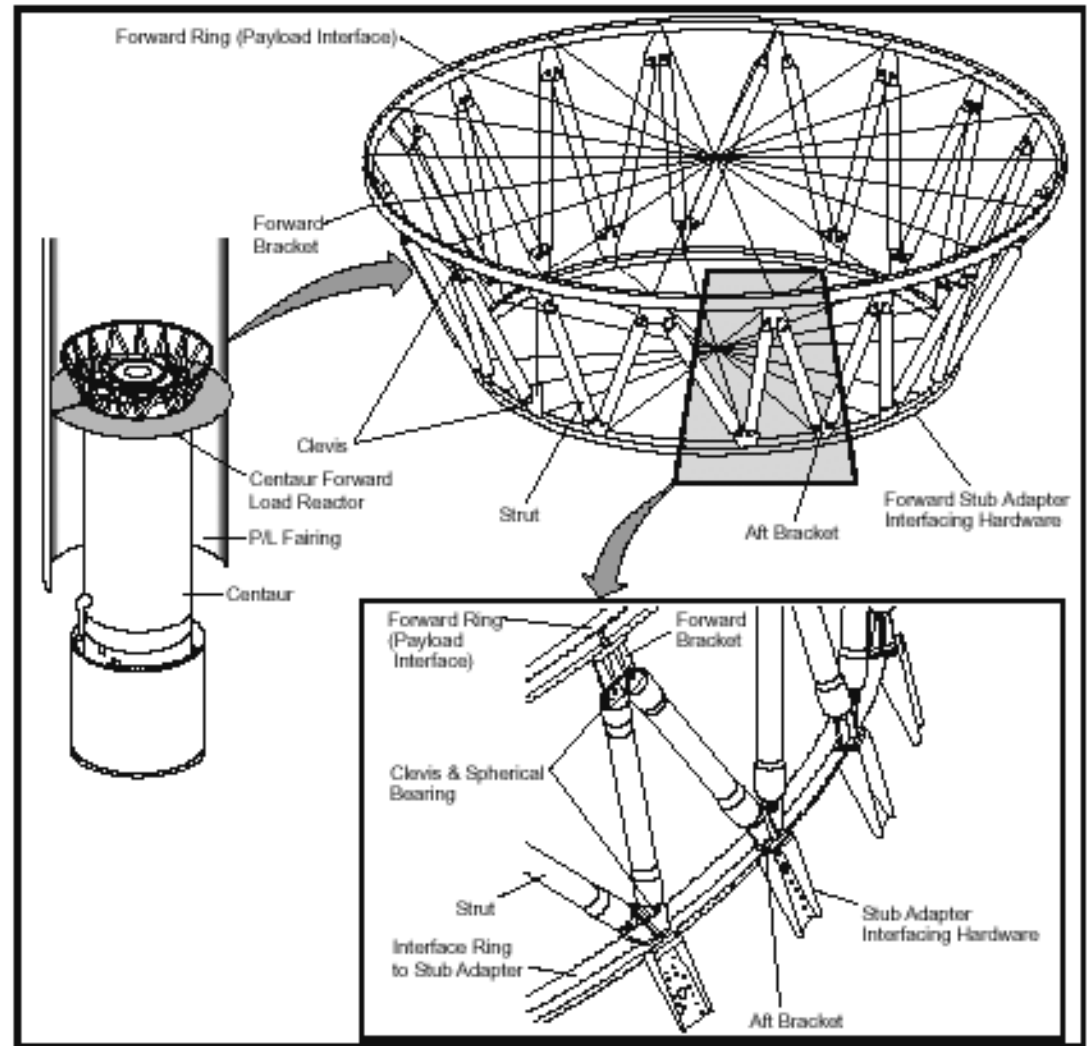
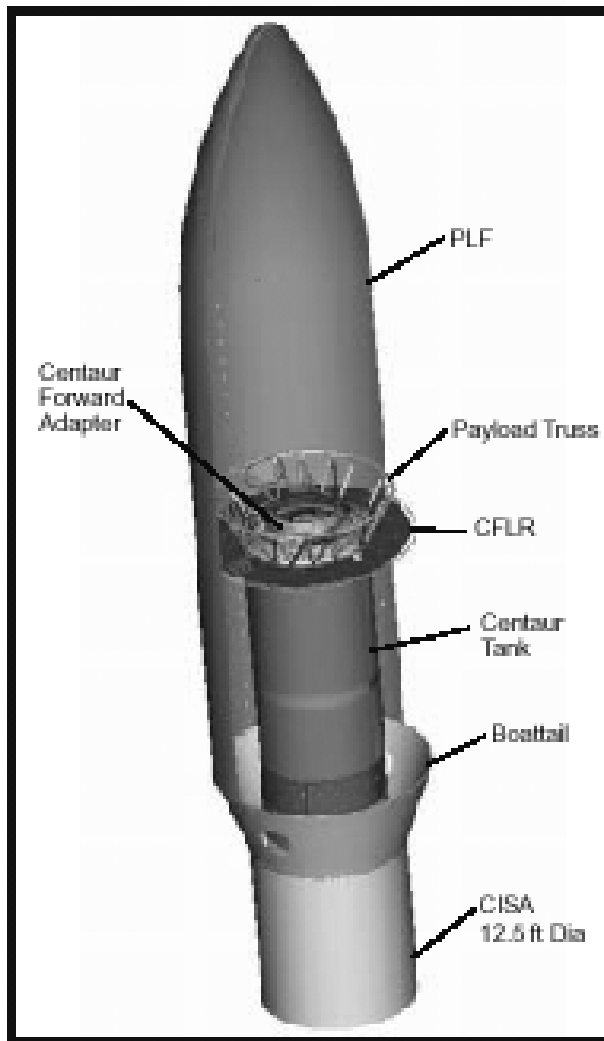

Delta IV Bolted Payload Attach Fitting

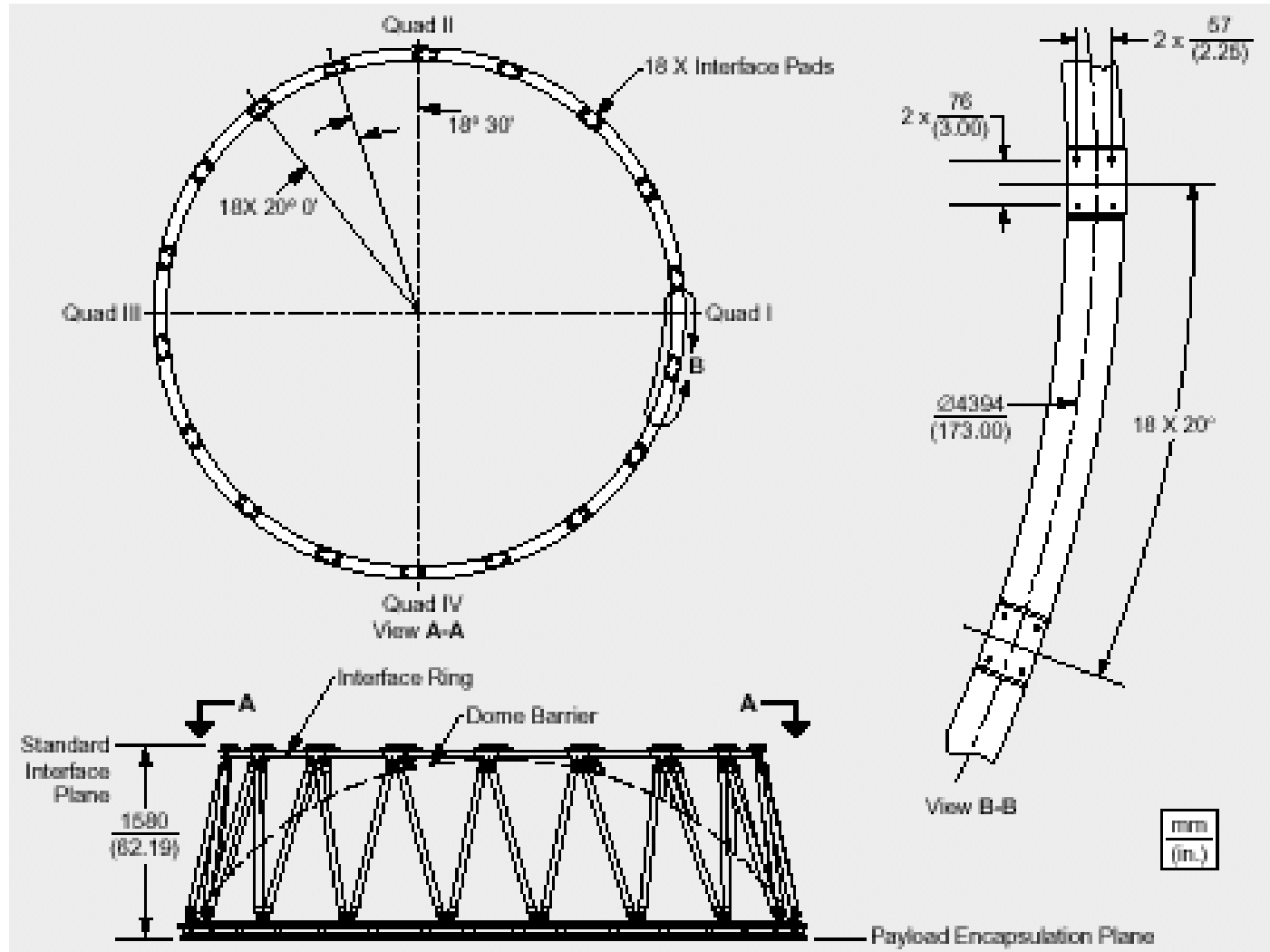

Delta IV Pyro Payload Attach Fitting

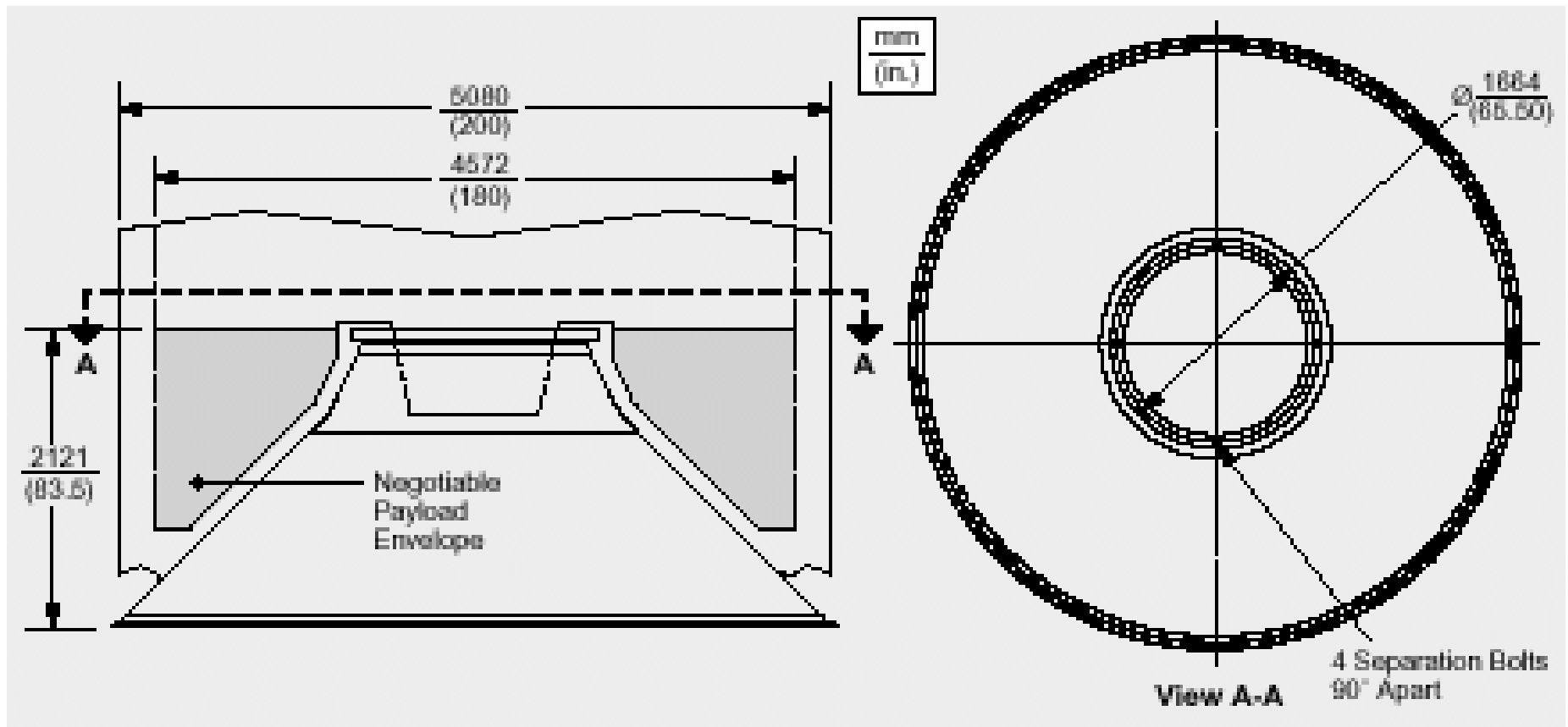

Delta IV Marmon Band PAF

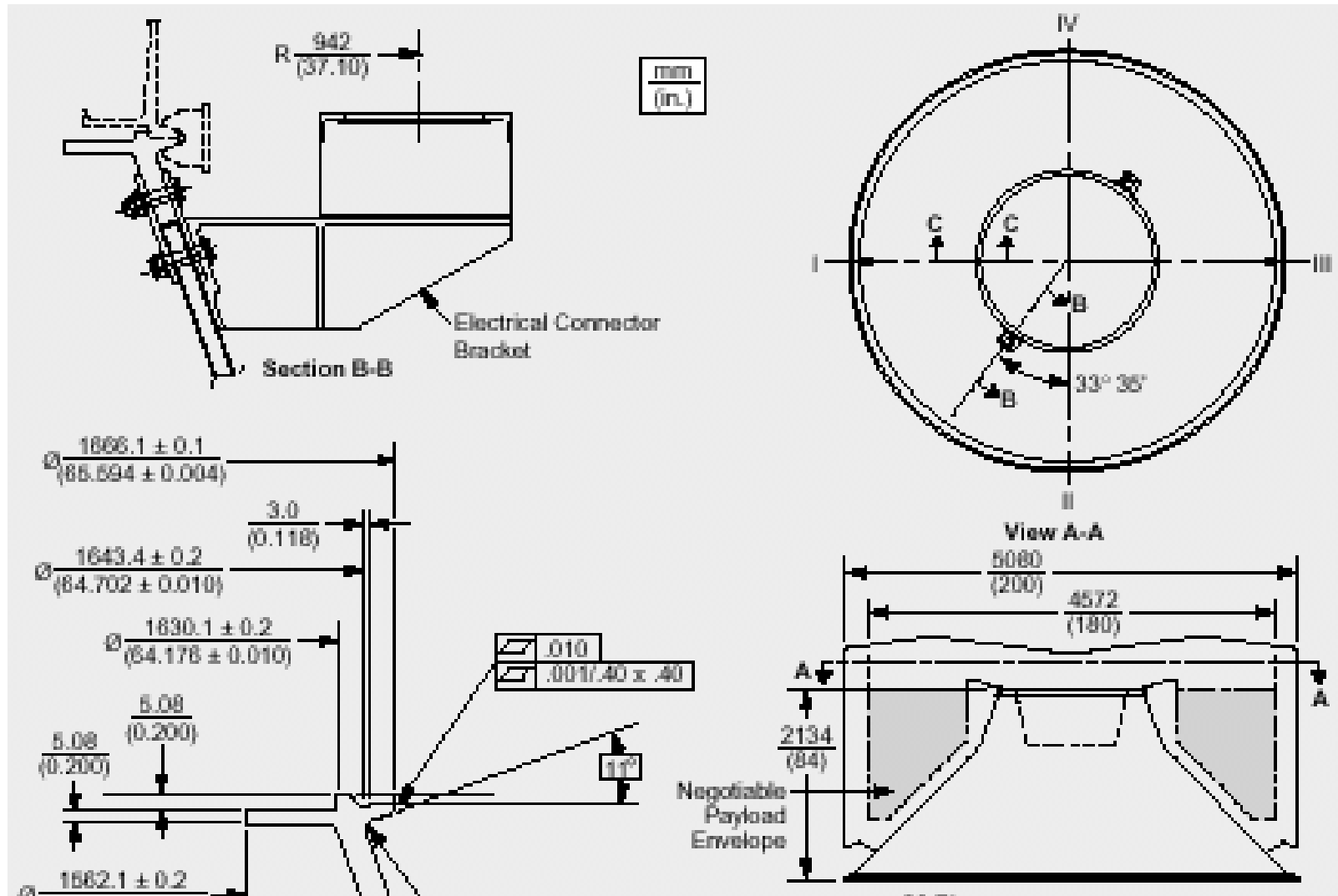

Saturn V First Stage (S-IC) Cutaway

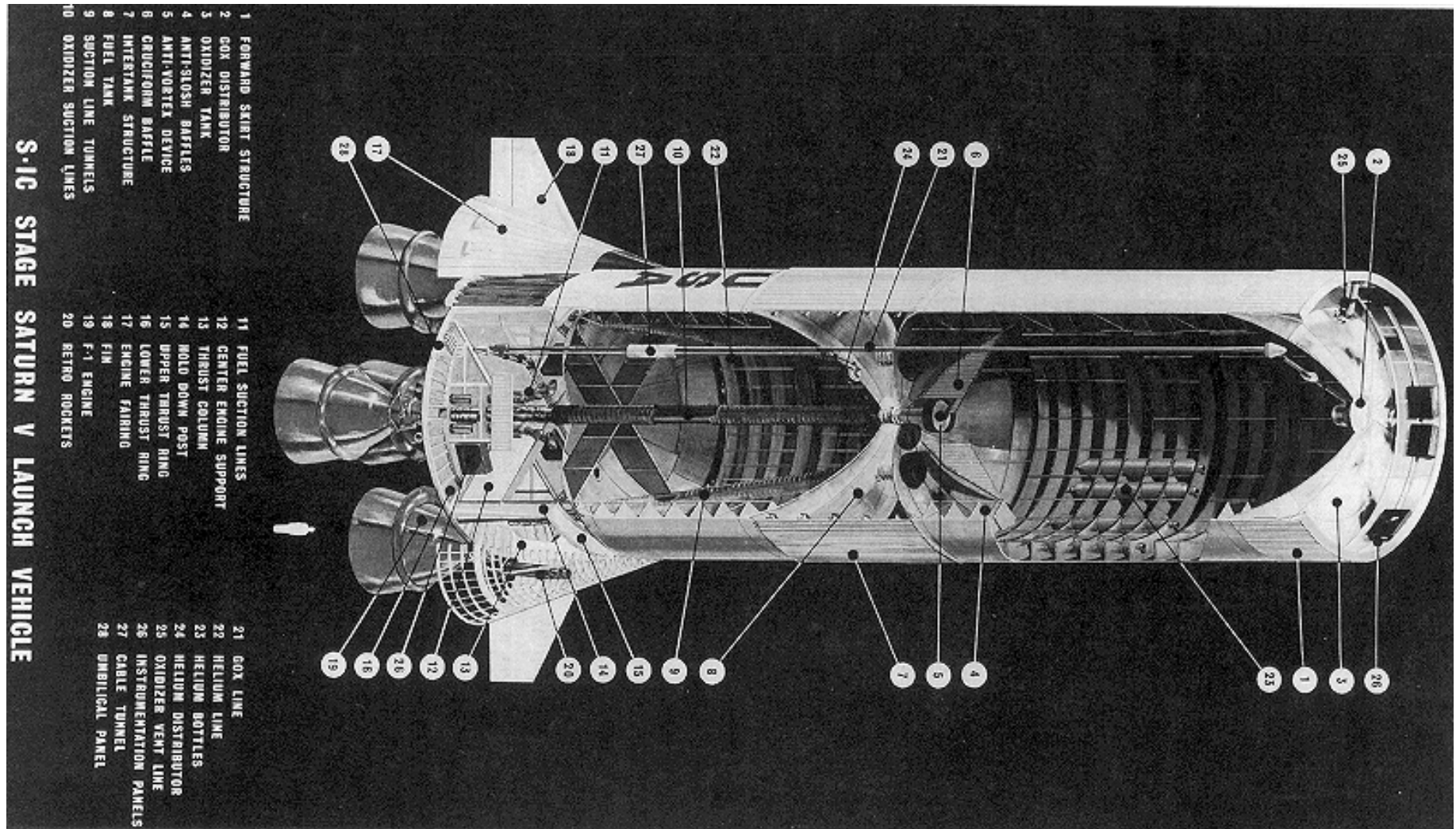

Saturn V S-IC Intertank Fairing



Saturn V S-II LOX Tank Cutaway

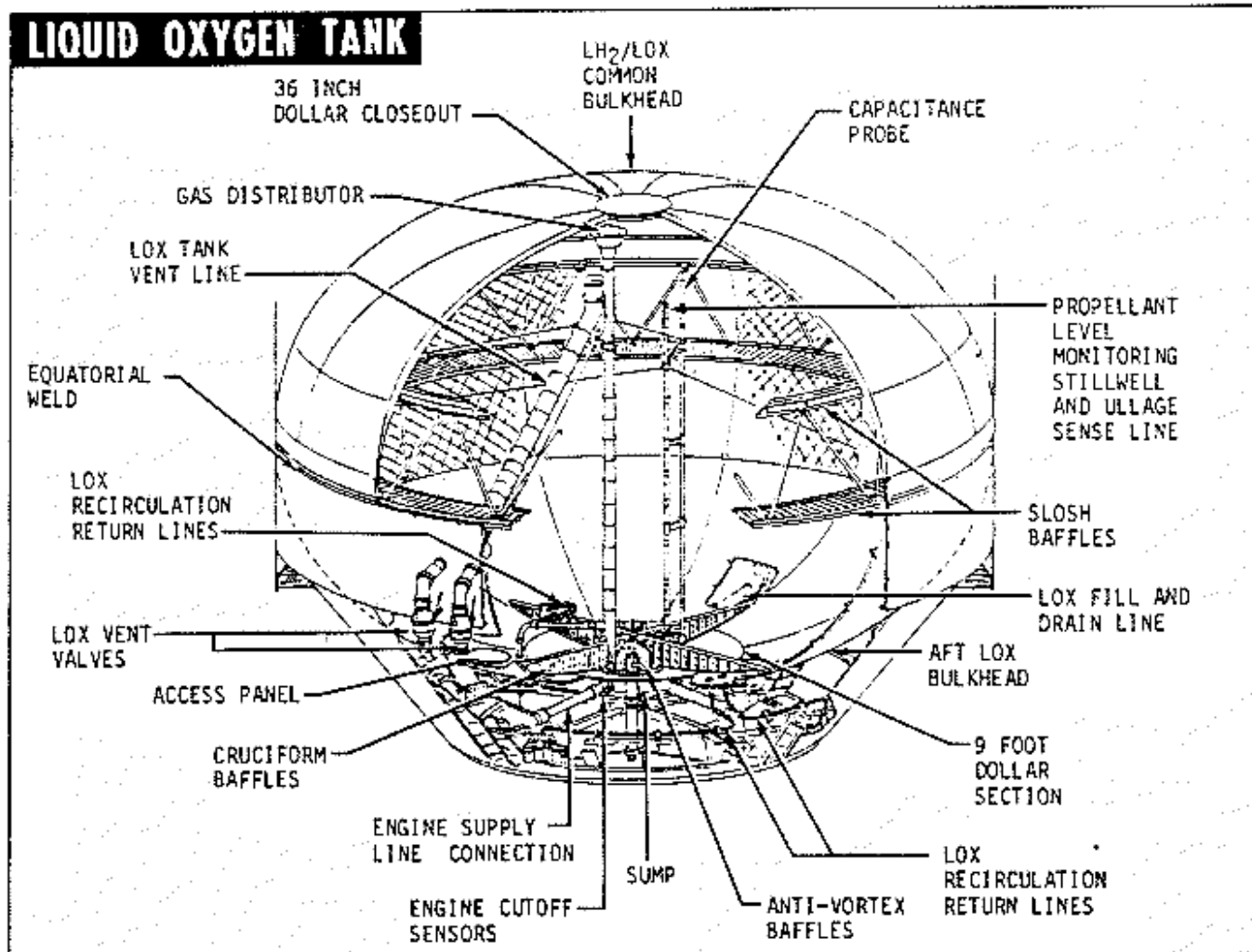

Saturn V S-II Thrust Structure Detail

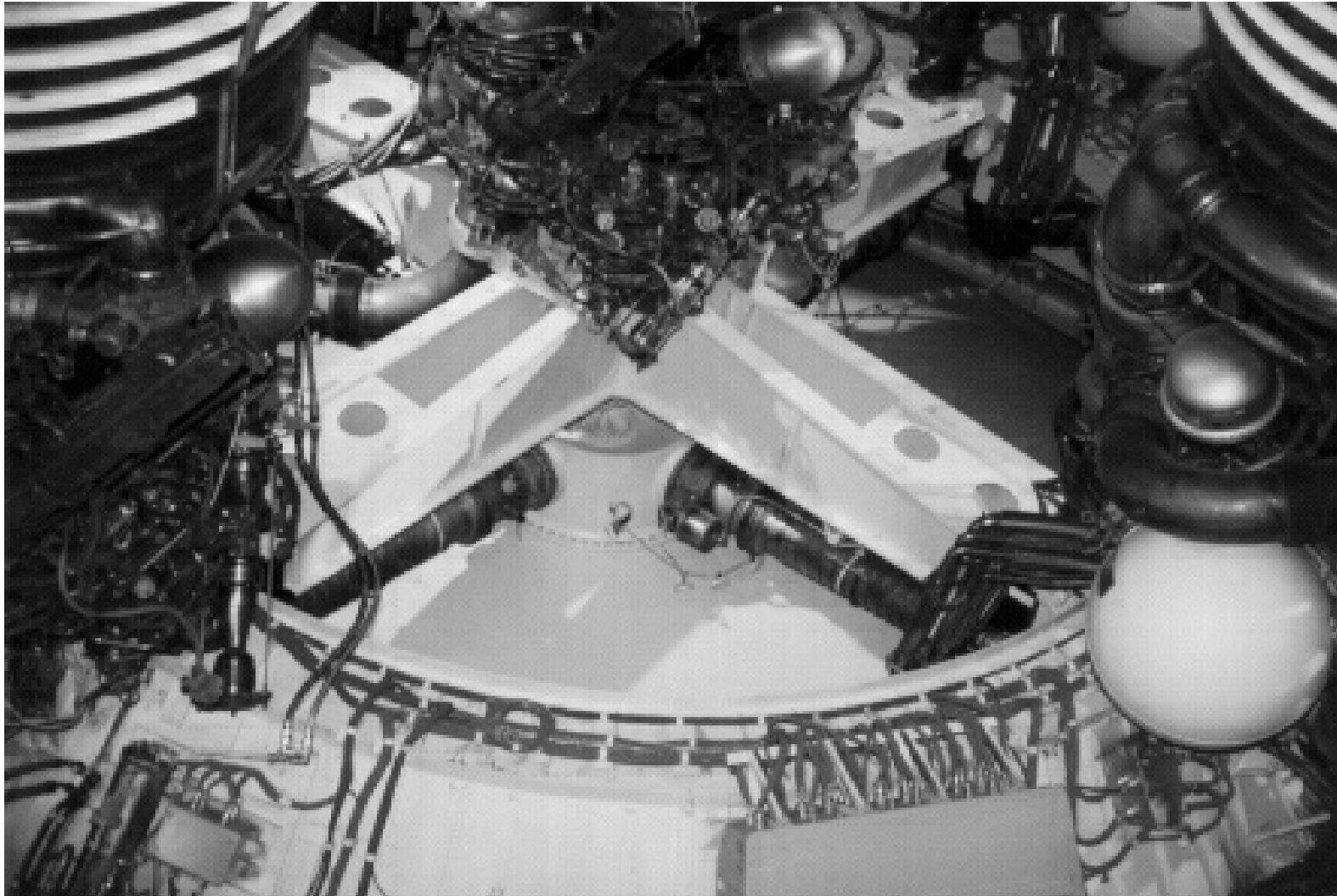

Saturn V S-IVB/J-2 Thrust Structure



UNIVERSITY OF
MARYLAND

Structural Practices
Principles of Space Systems Design

Lunar Module Overall Configuration

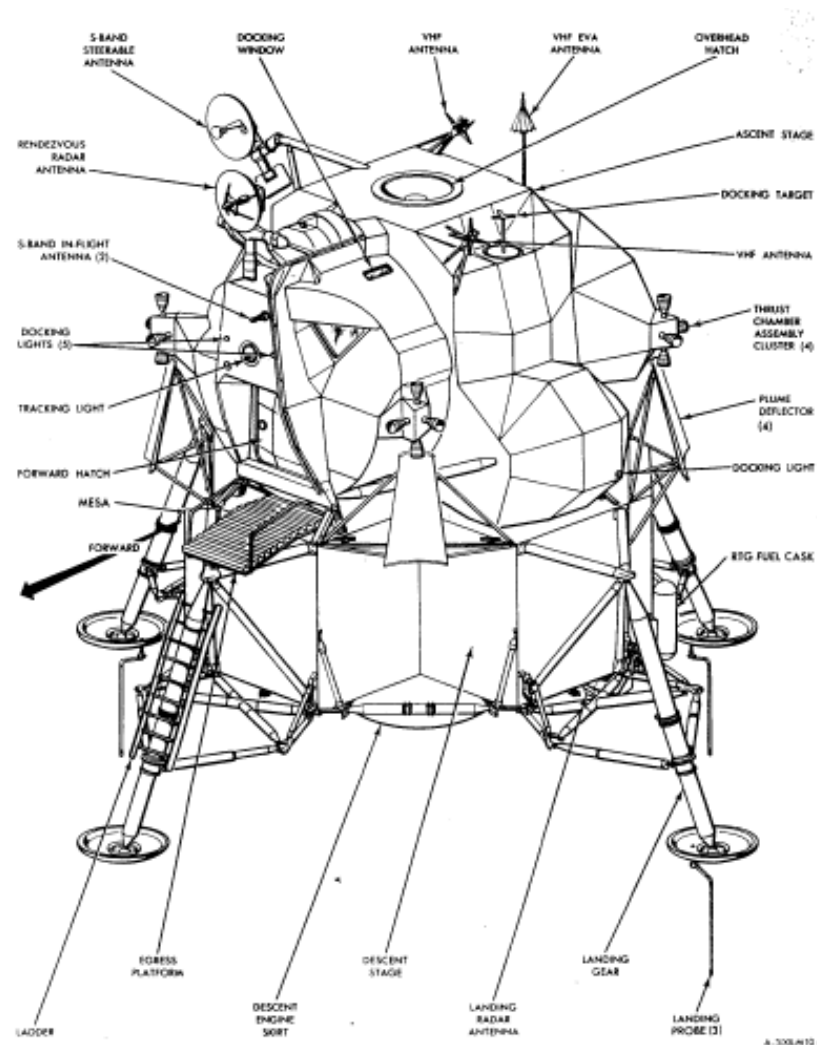

Lunar Module Ascent Stage Structure

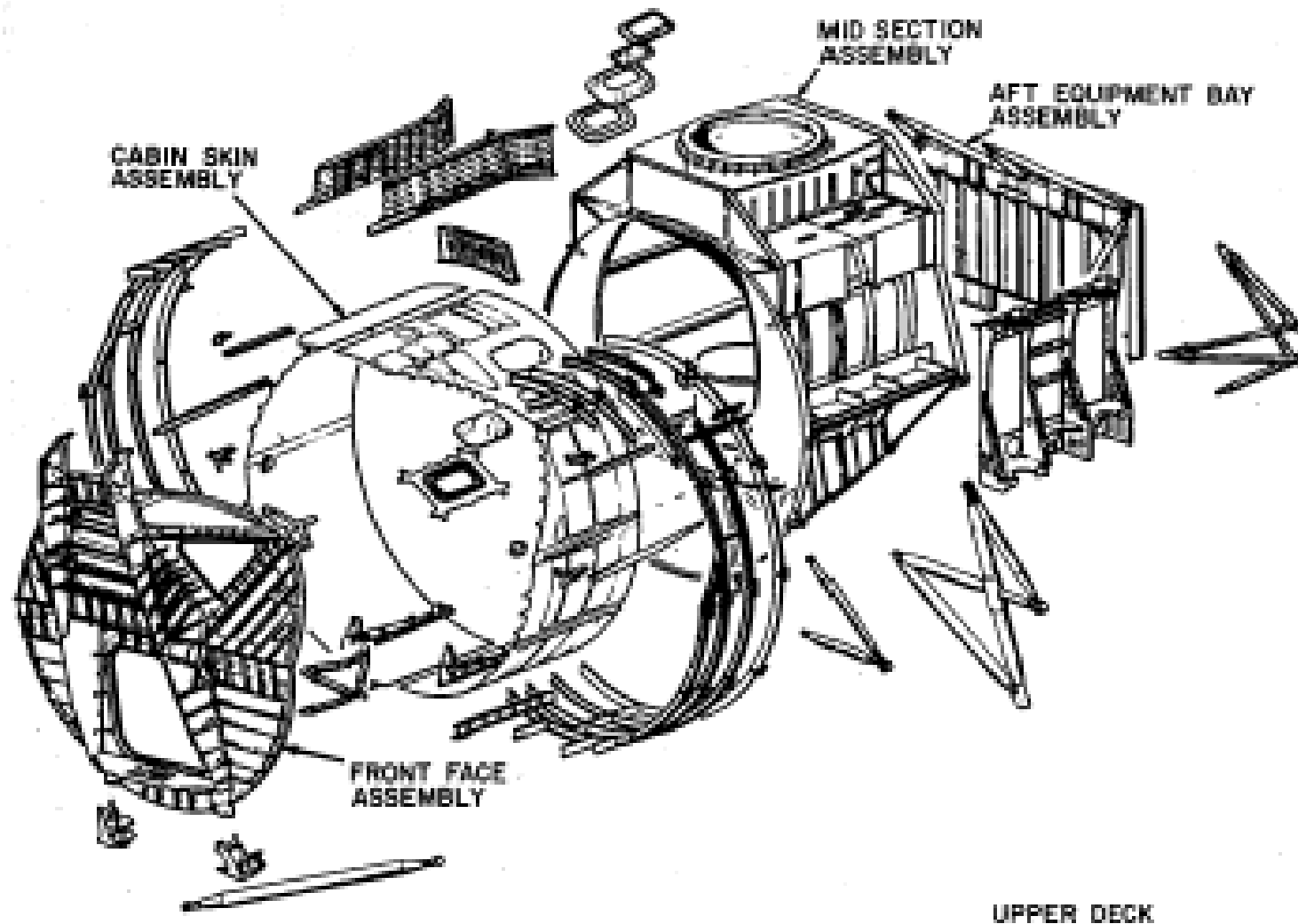

Lunar Module Ascent Stage Structure

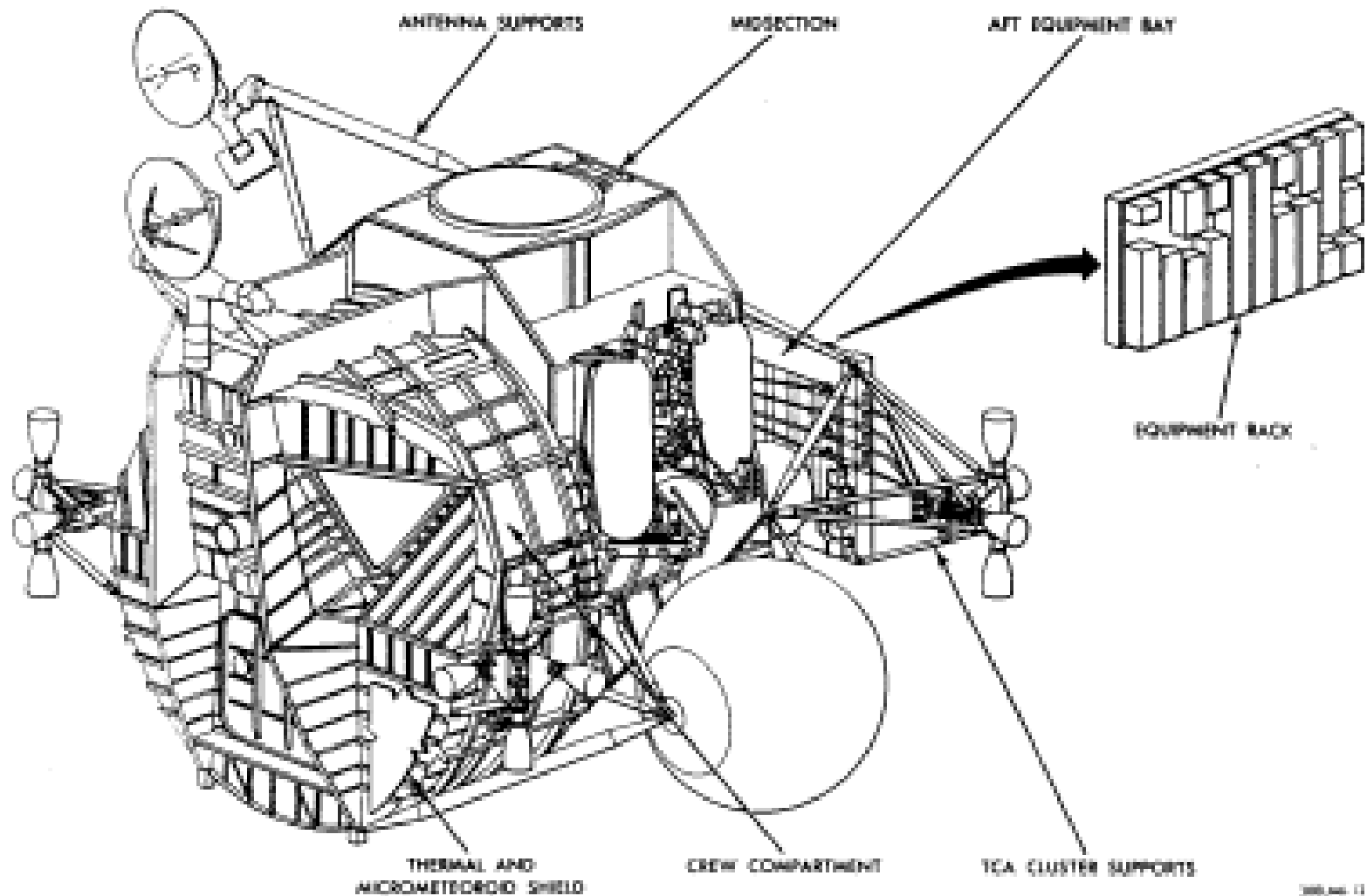

Lunar Module Descent Stage Structure

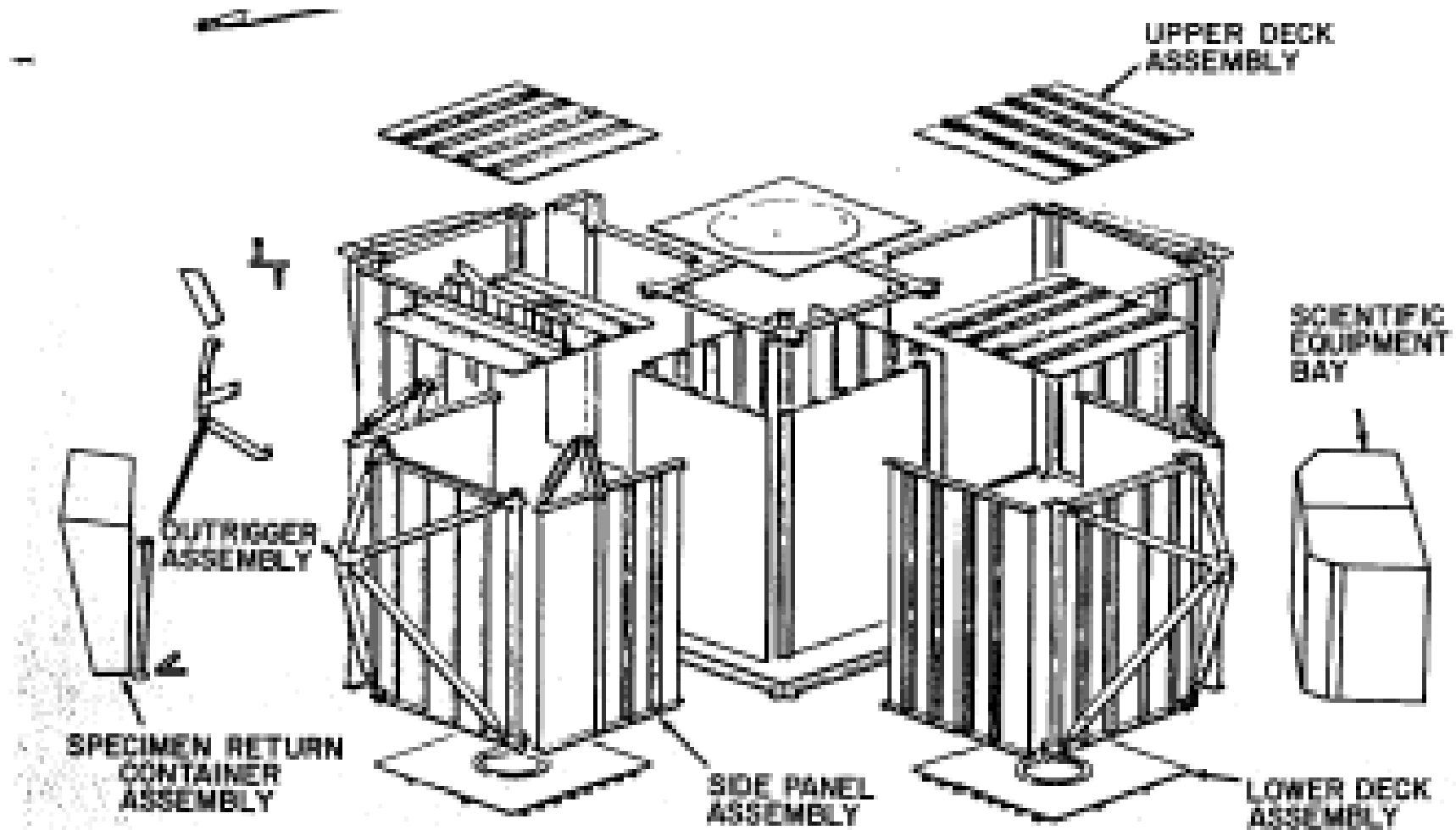

Lunar Module Descent Stage Structures

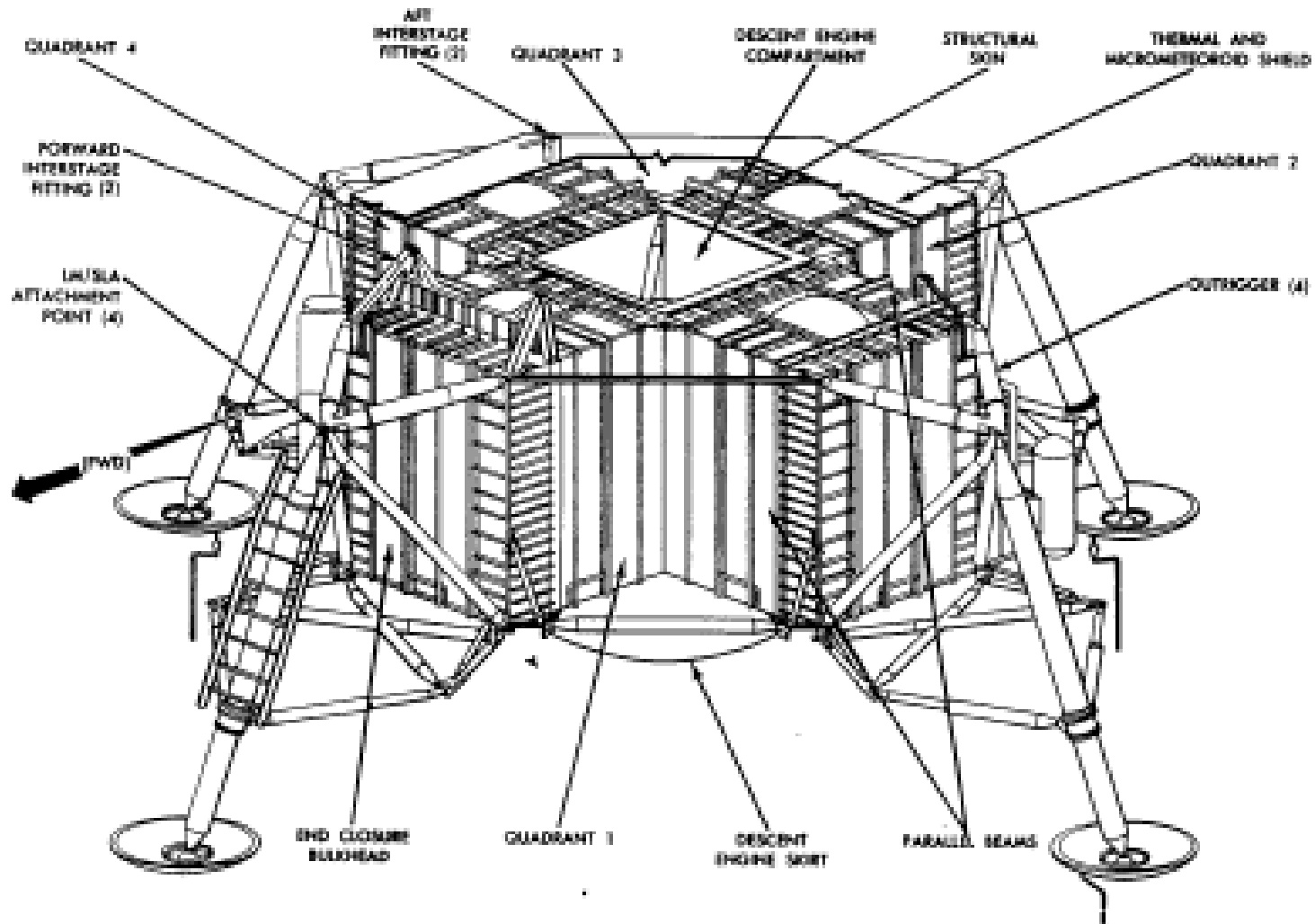

300M10-3



Gemini Spacecraft Equipment Arrangement

GEMINI EQUIPMENT ARRANGEMENT

