

Steering and Suspension Systems Overview

- Steering Systems
 - Skid-Steer
 - Differential drive
 - Trailer steering
 - Ackerman steering
 - Actively controlled steering (Independent/explicit)
 - Holonomic vs. Nonholonomic Systems
- Suspension Systems
 - Rigid Suspension
 - Independent Suspension
 - Articulated / Split-Body Suspension
 - Rocker-Bogie Configurations
 - Segmented-Body Rovers
 - Active Suspension

© 2022 David L. Akin - All rights reserved
<http://spacecraft.ssl.umd.edu>

Skid Steering (Skid-Slip Steering)

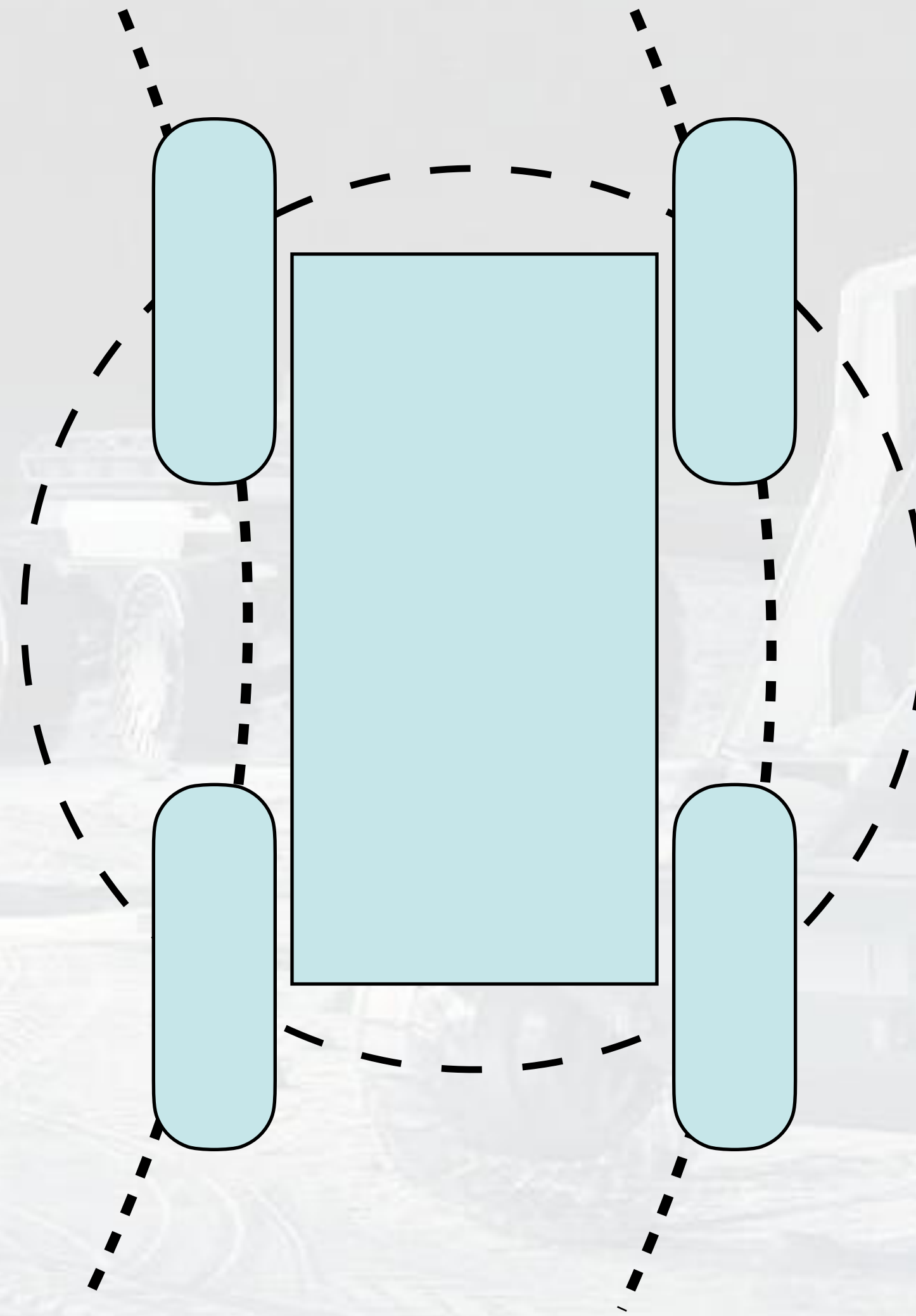

Rigid Suspension, Skid Steer



Electric Tractor, NASA Johnson Space Center



Electric Tractor Drive System



Rigid Suspension in Hilly Terrain



ATRV Skid-Steer Robots



RAVEN (4-wheel configuration)



Differential Drive (Swiveling Wheels)

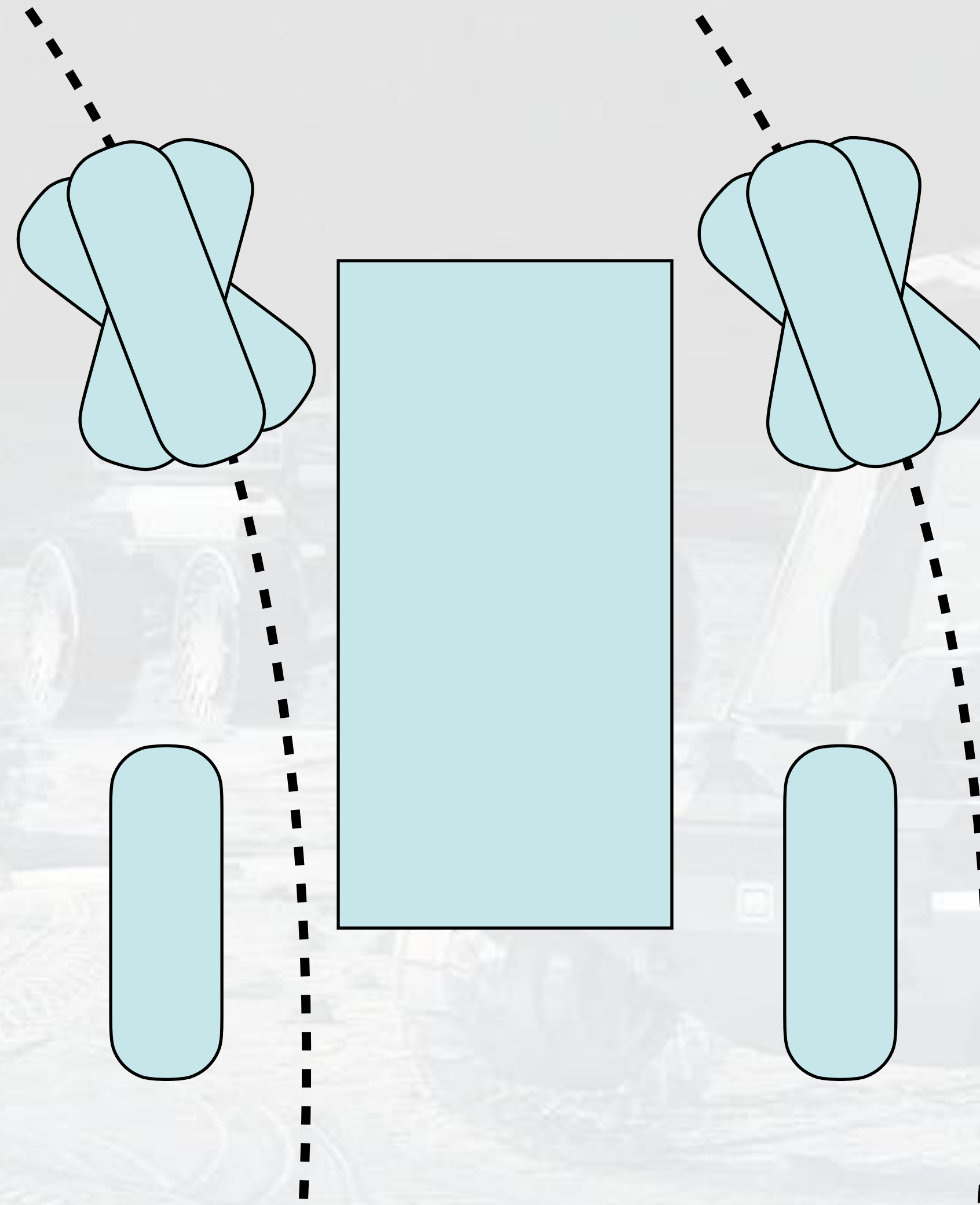

Laboratory Robot (CMU)



Laboratory Robot (CMU)



RAVEN (UMd/ASU)



UNIVERSITY OF
MARYLAND

Steering and Suspension Systems Overview
ENAE 788X - Planetary Surface Robotics

RAVEN in Mobility Testing



Ackermann Steering

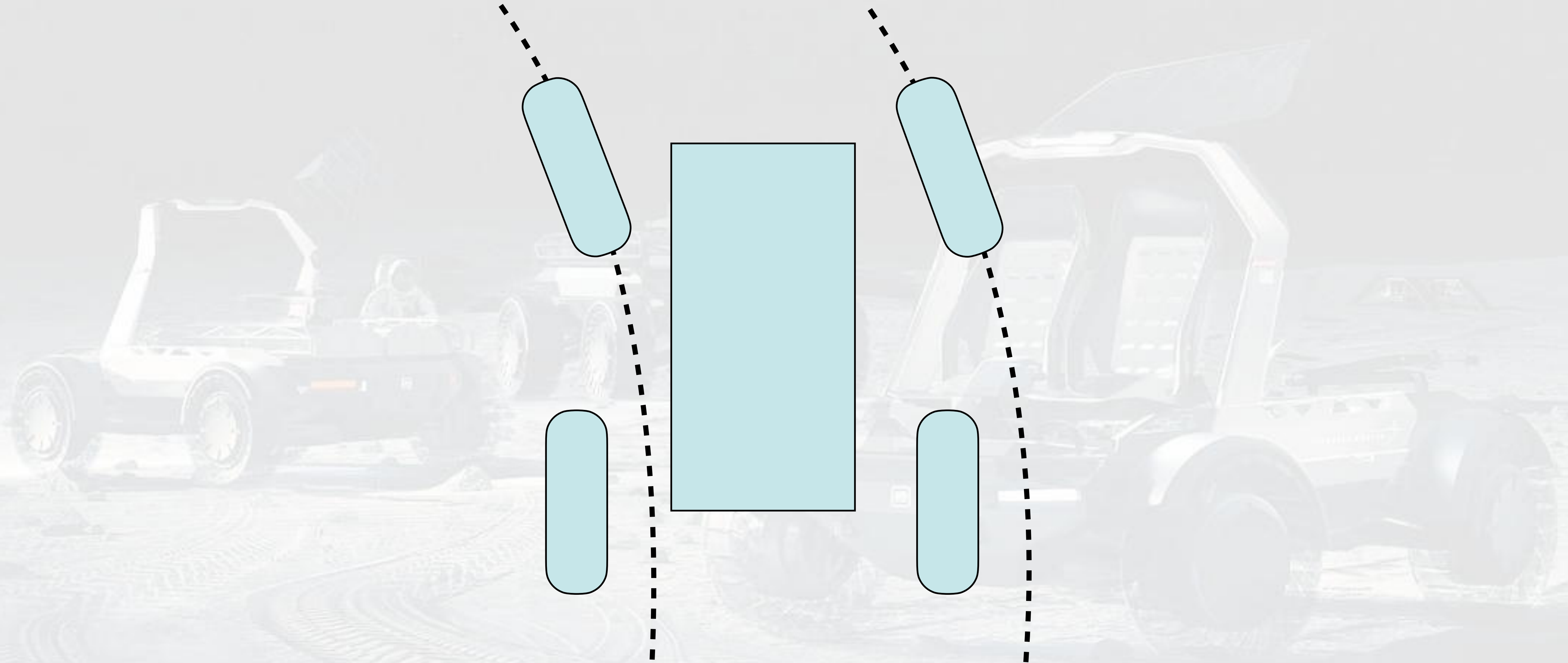

Ackermann Steering Geometry

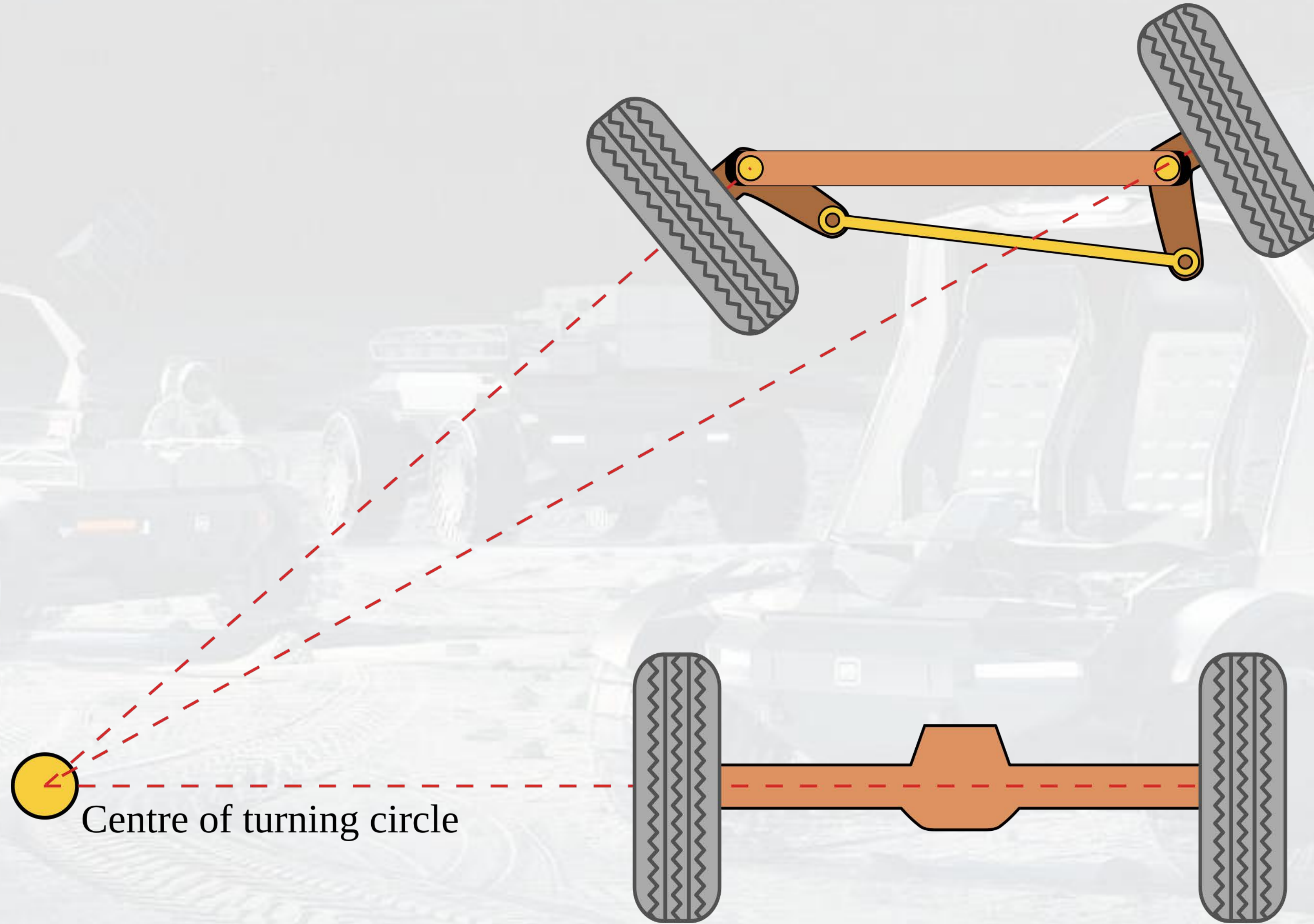

Tooth (JPL) - Ackermann Steering



Trailer Steering

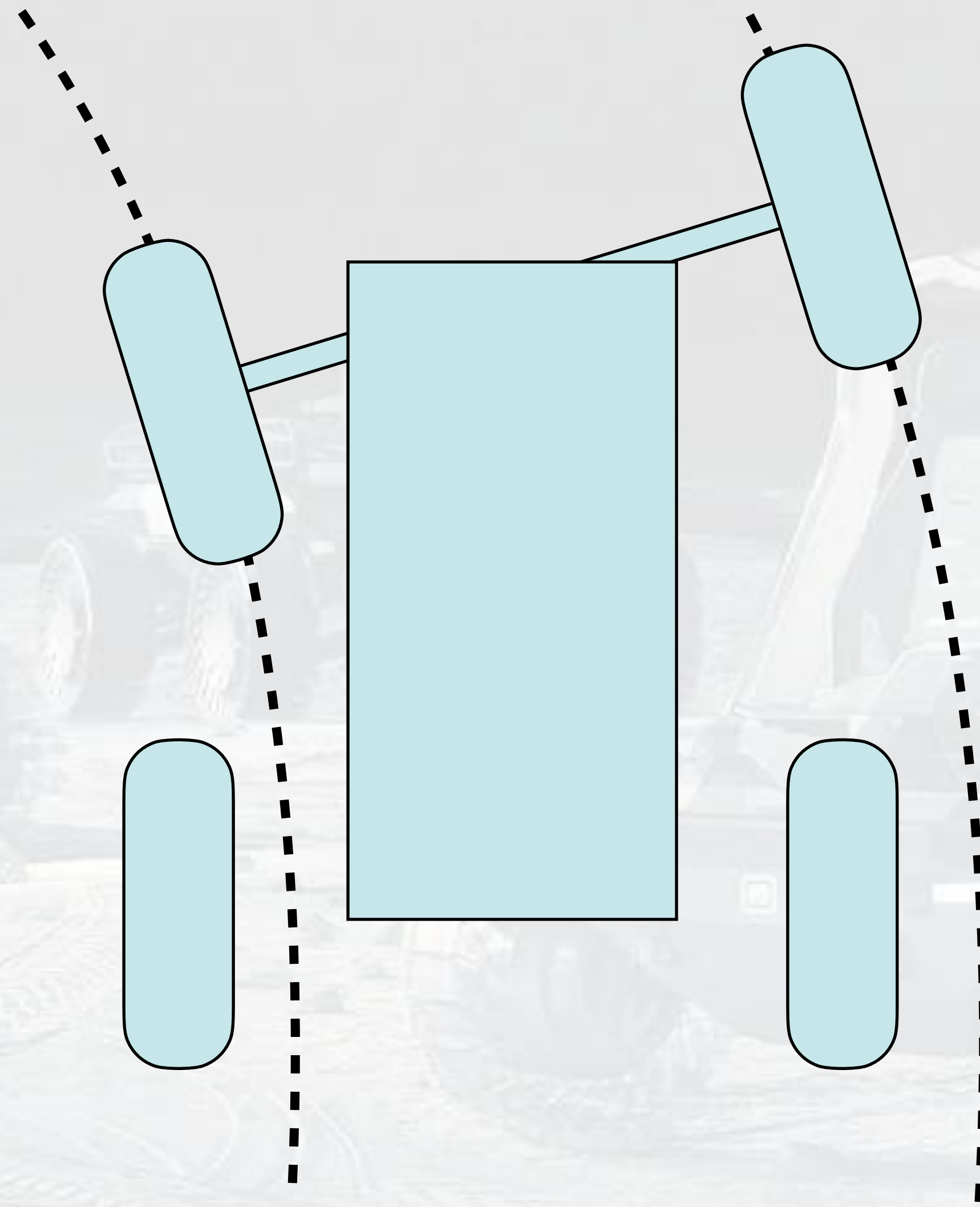

Hyperion (CMU)



Hyperion (CMU) - Trailer Steering

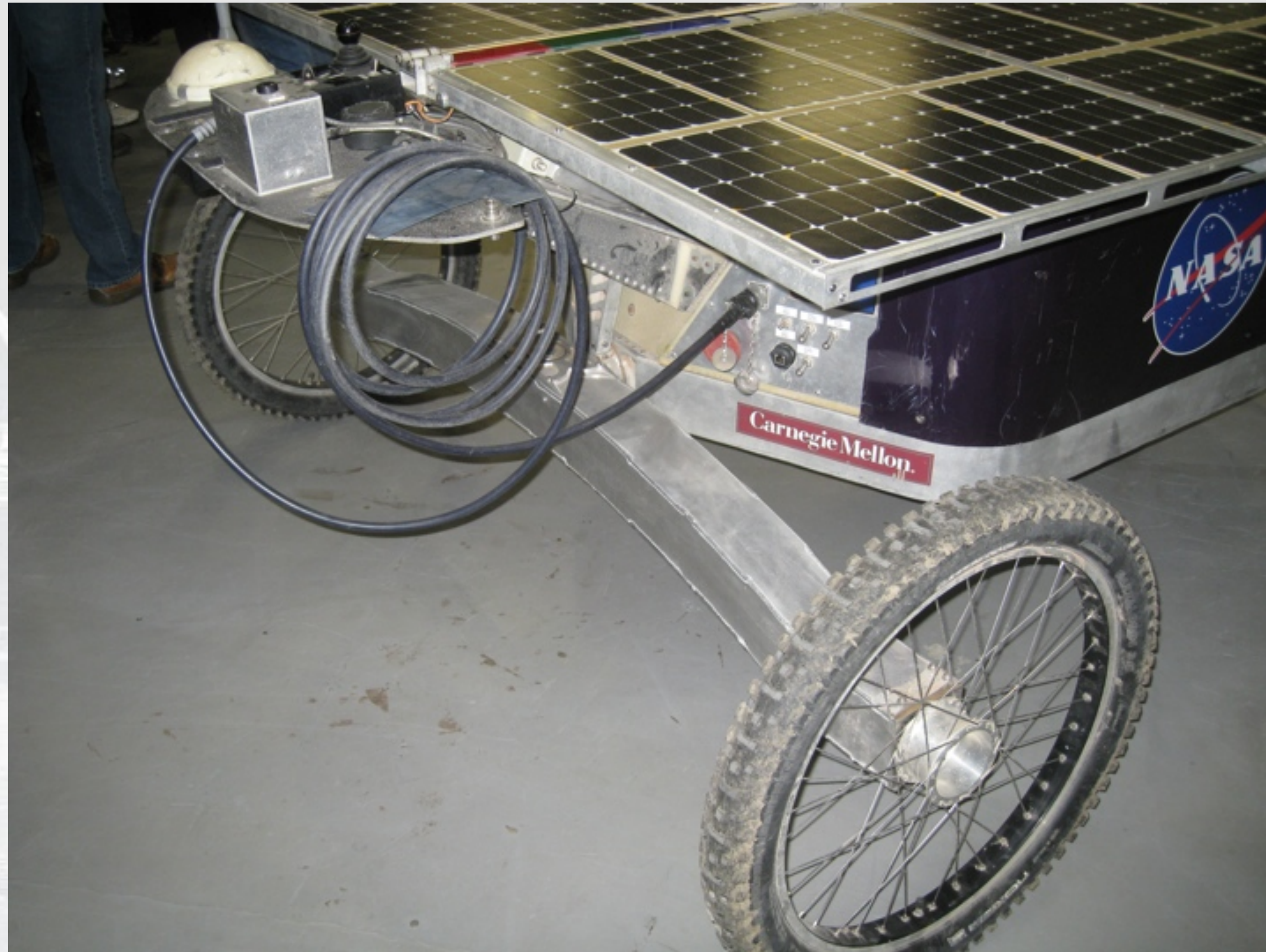

Independent Suspension (Towed Vehicle)



SCOUT Astronaut Support Rover (JSC)



SCOUT Suspension and Steering System



Steering Schemes

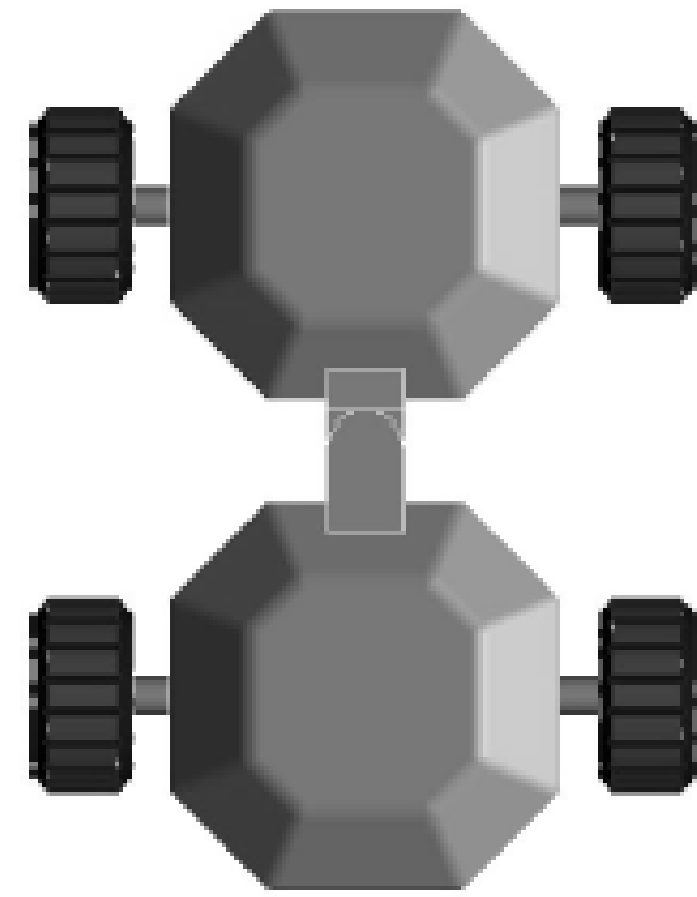

ARTICULATED

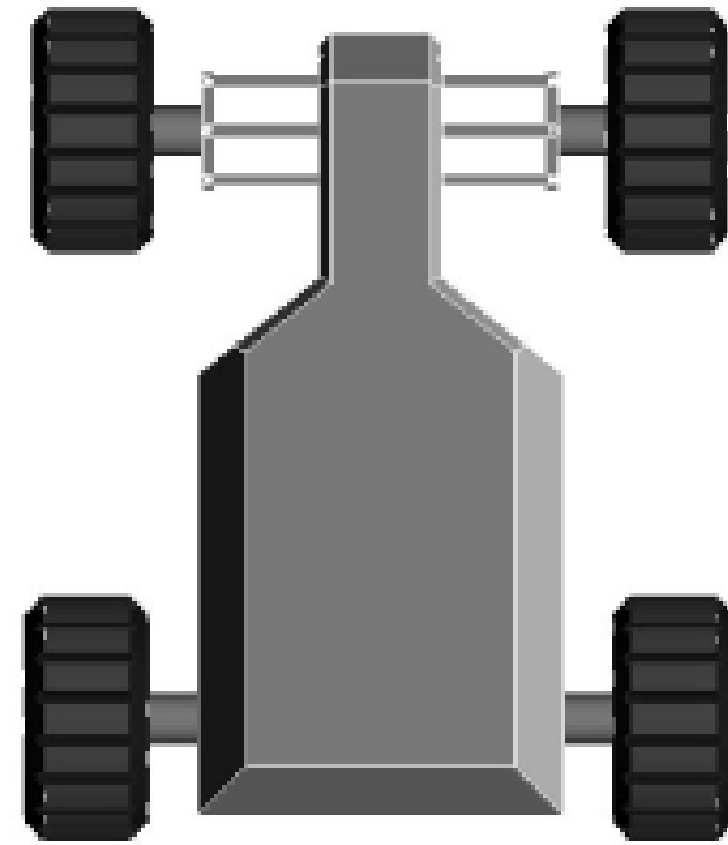

COORDINATED
(Ackermann Type)

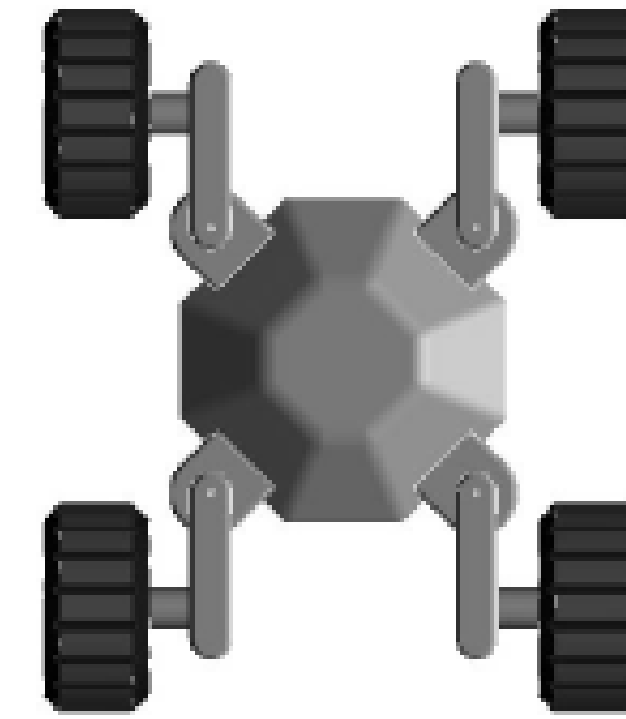

INDEPENDENT
EXPLICIT

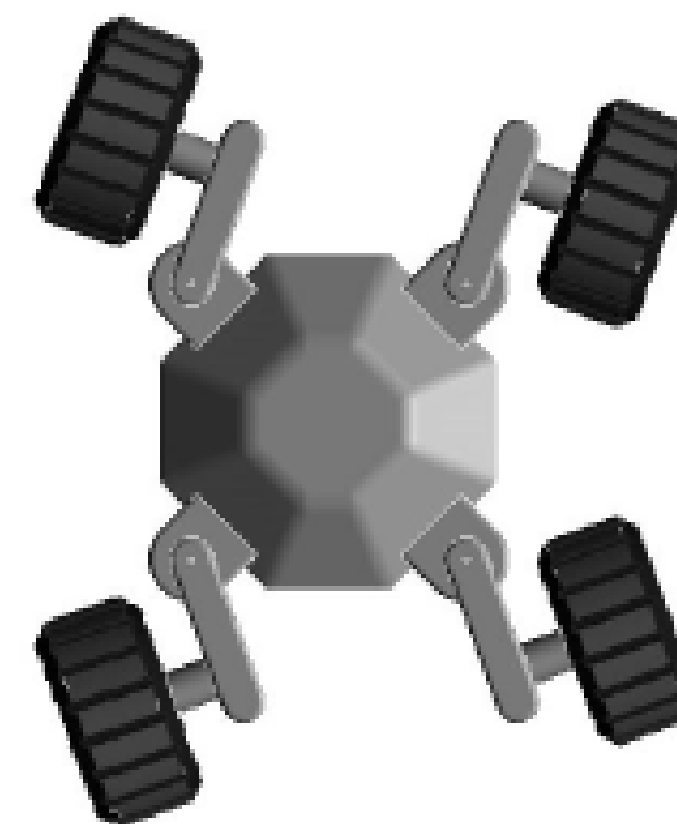
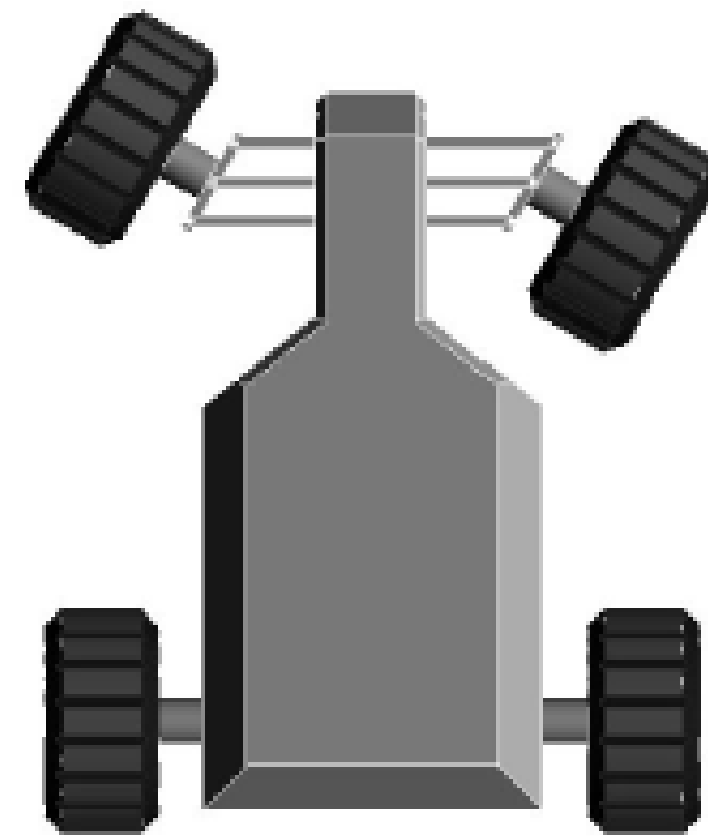
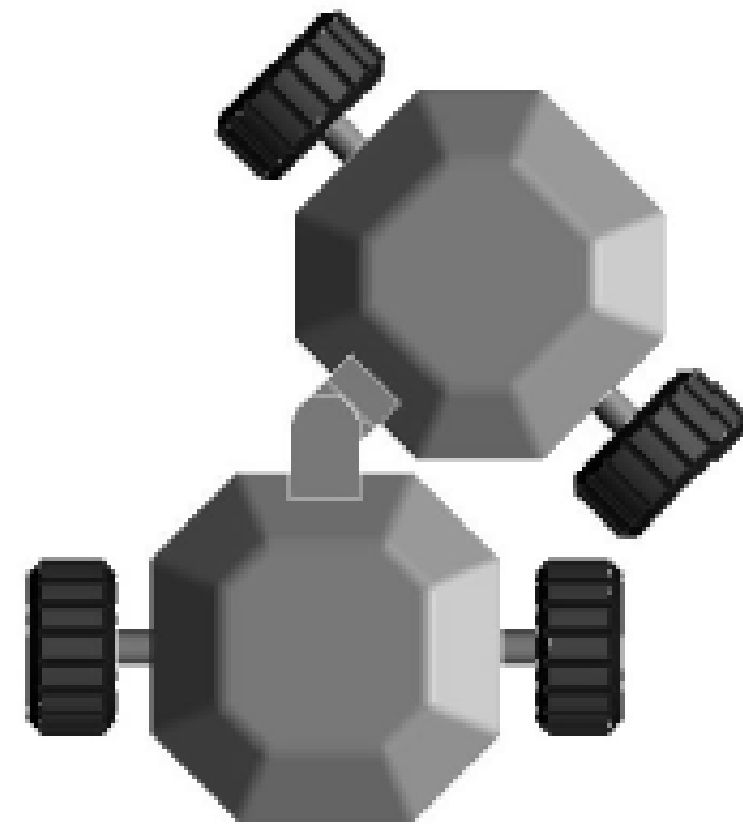

Articulating Suspension - Nomad (CMU)



Nomad Transforming Chassis

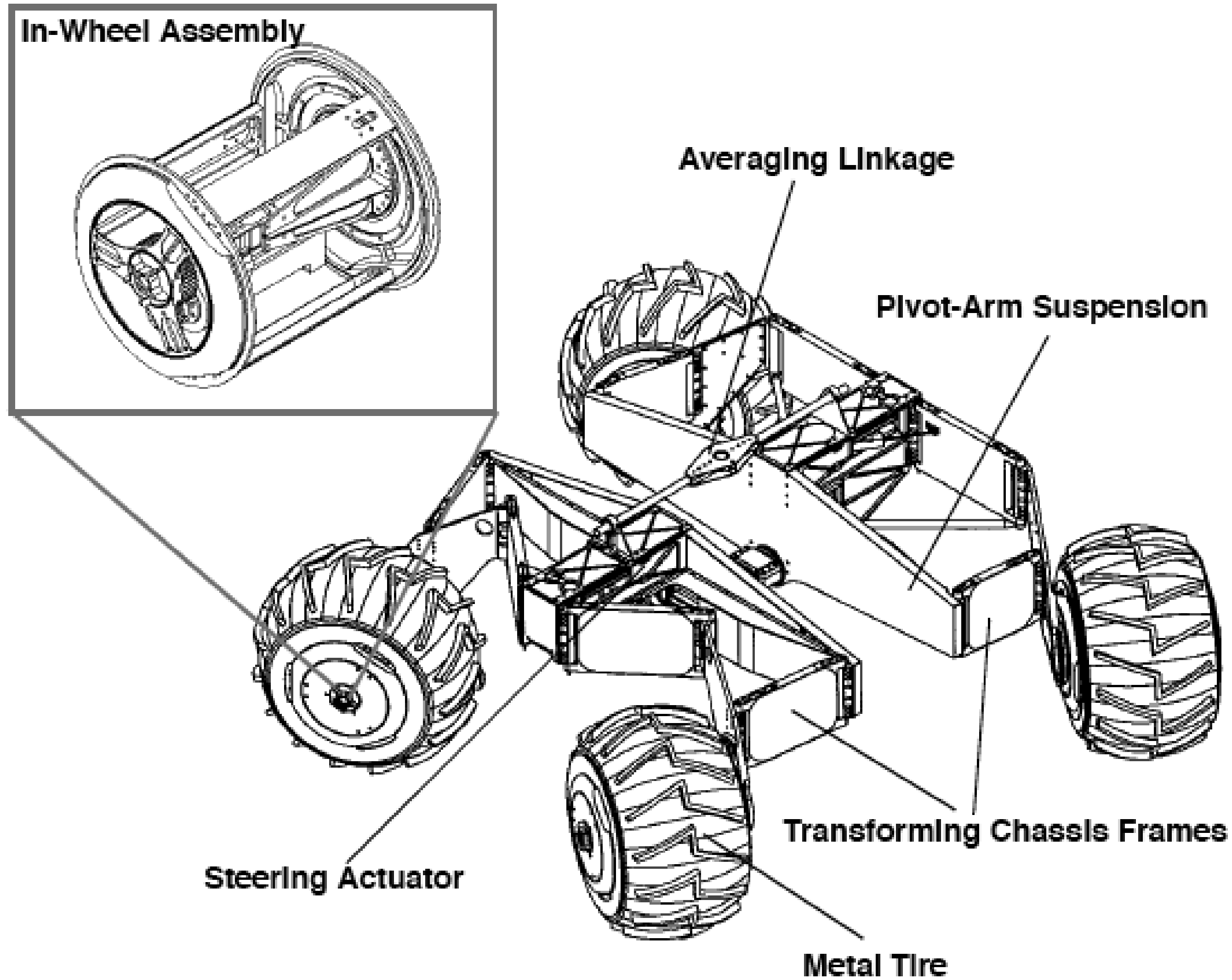

Nomad in Rough Terrain



Nomad Chassis/Steering System

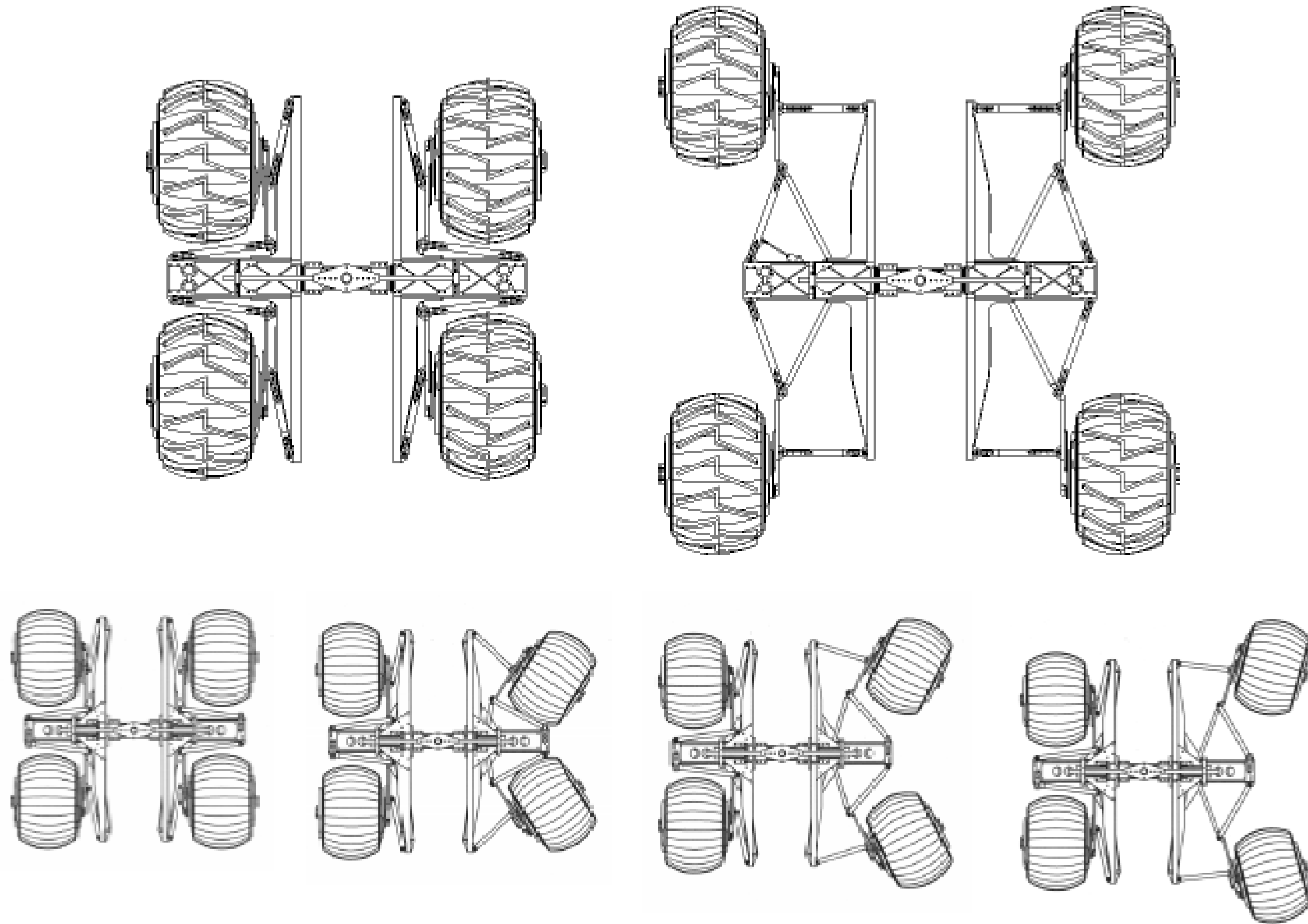

Nomad with Wheels Stowed



Nomad Steering Schemes

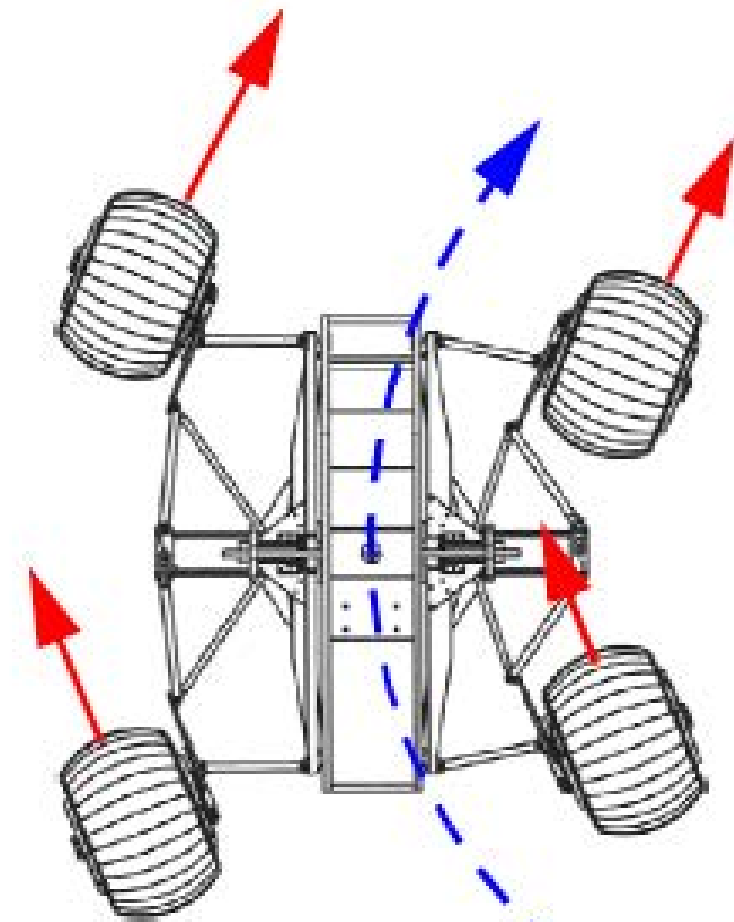

Dual Ackermann

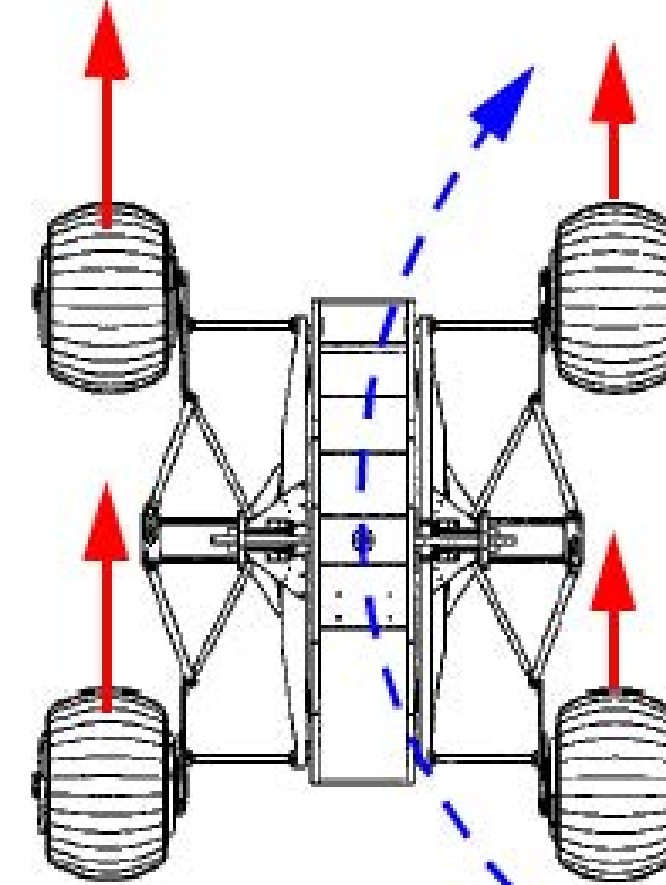

Differential Skid Steering

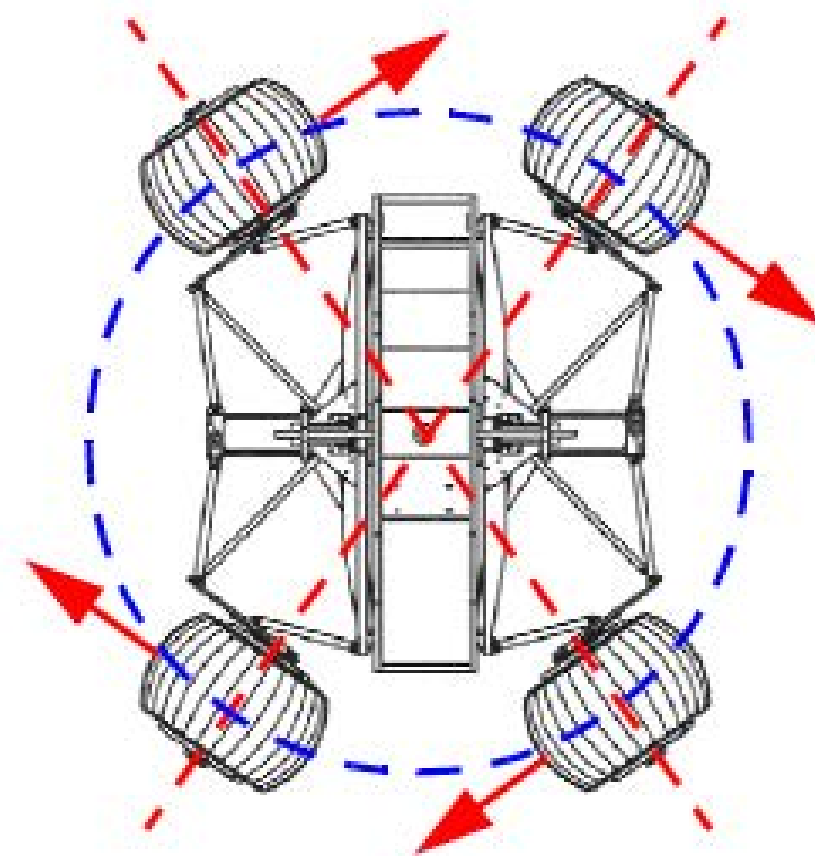

Rolling Point Turn

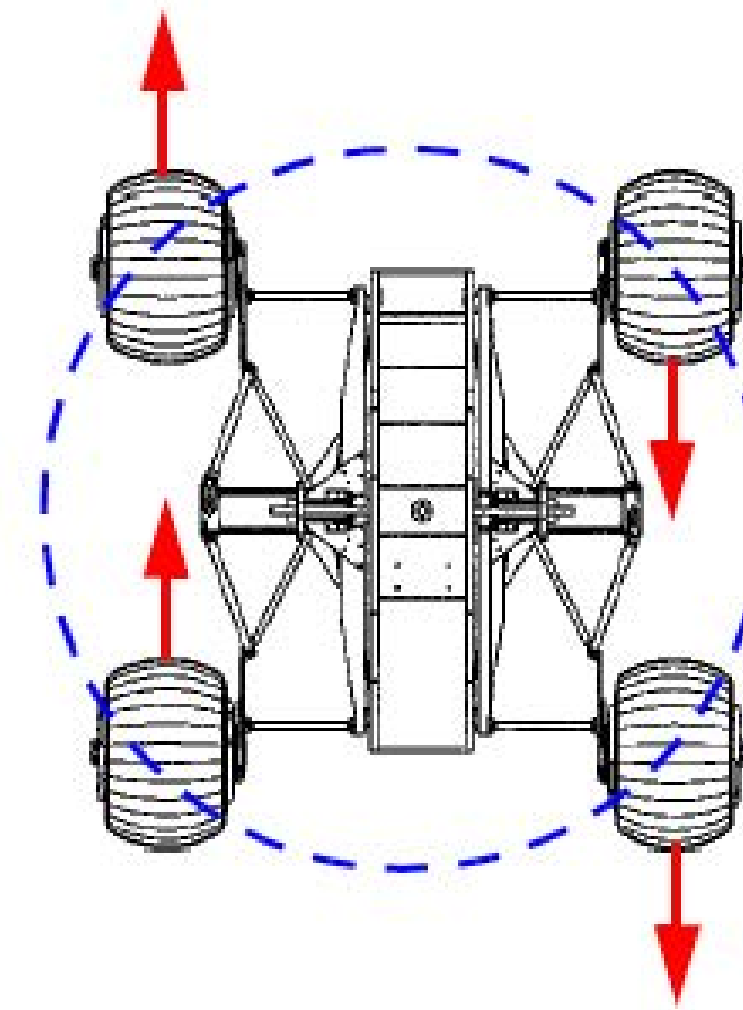

Skid Steering Point Turn



Nomad Power in Skid and Explicit Turns

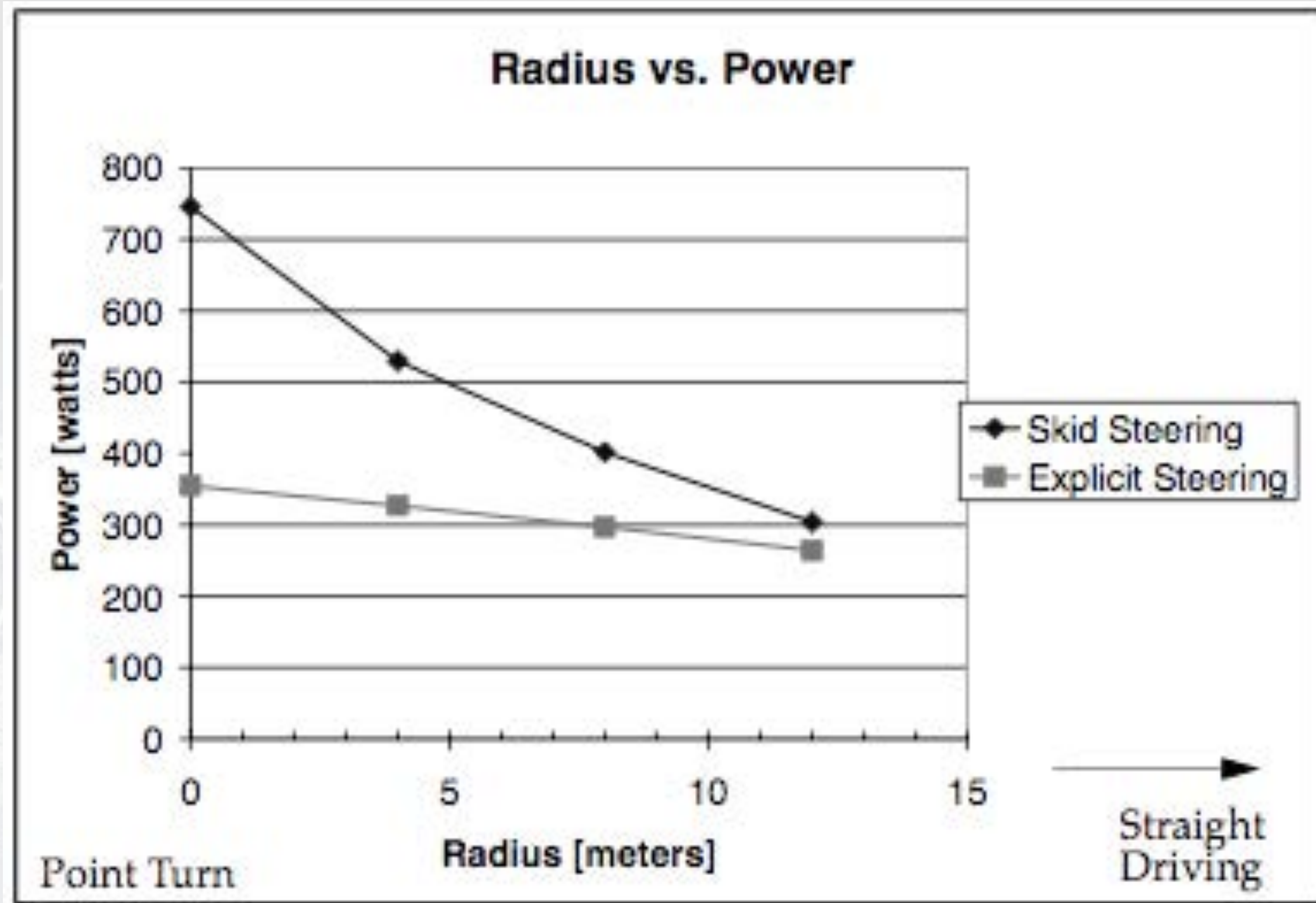

Steering Power Comparison with Fixed Loads

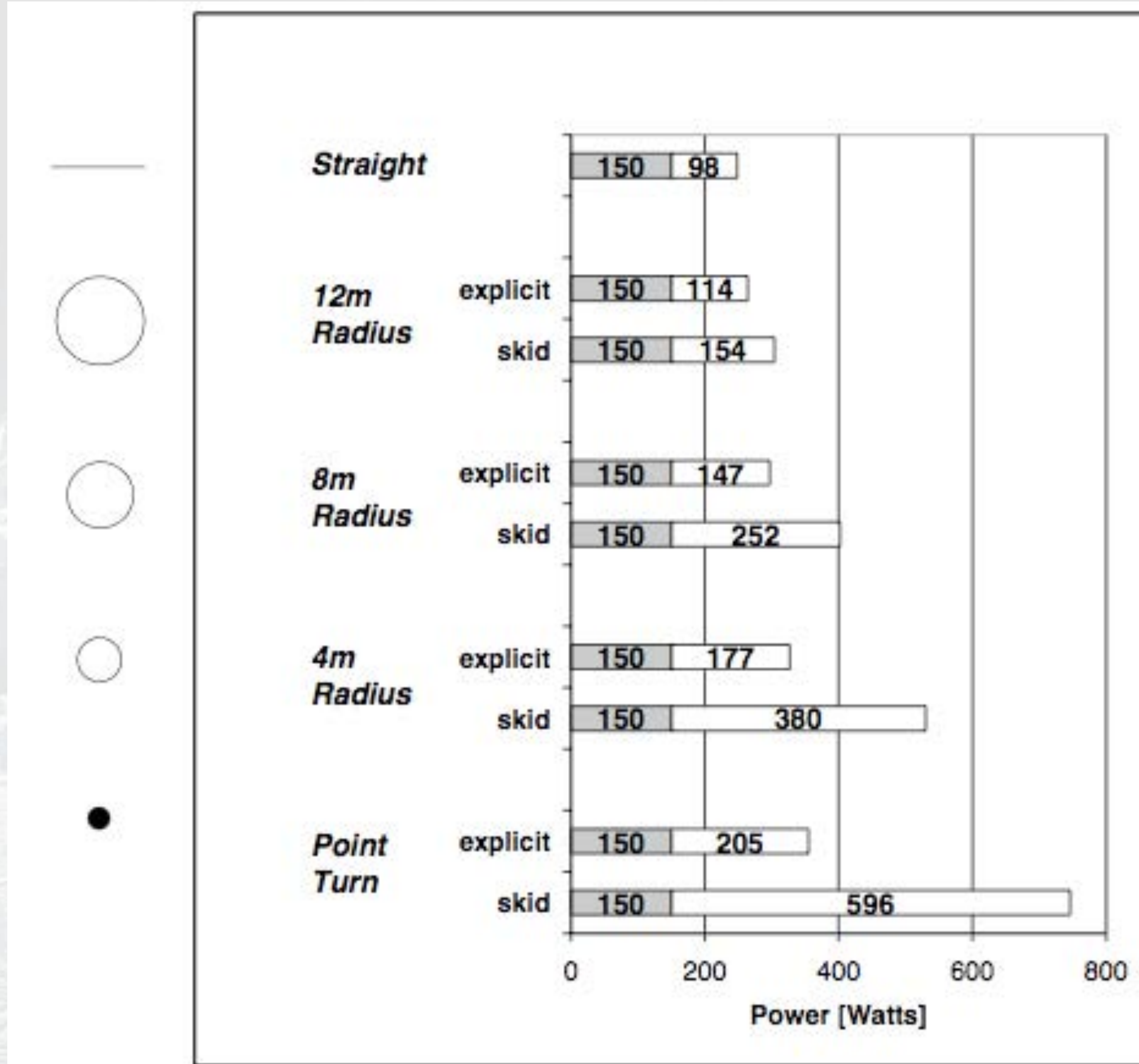

Nomad Wheel Torques in Skid Turn

% of total torque contribution by each wheel for 4m radius skid steering turns

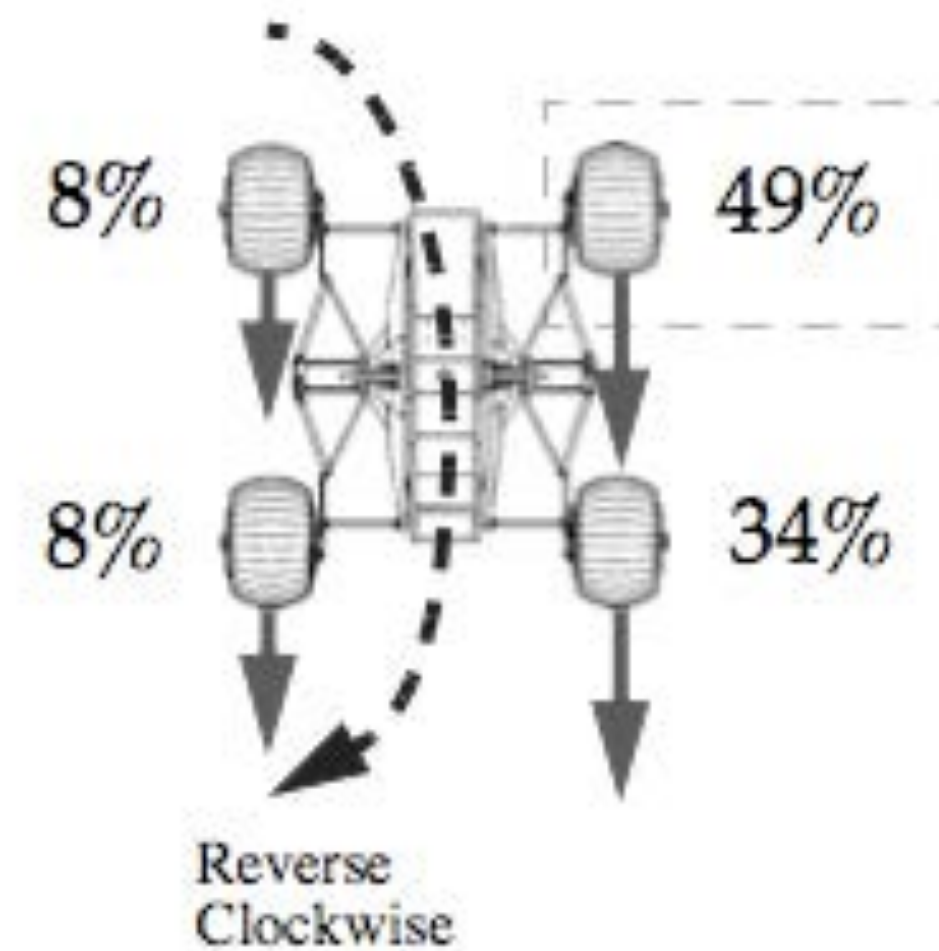
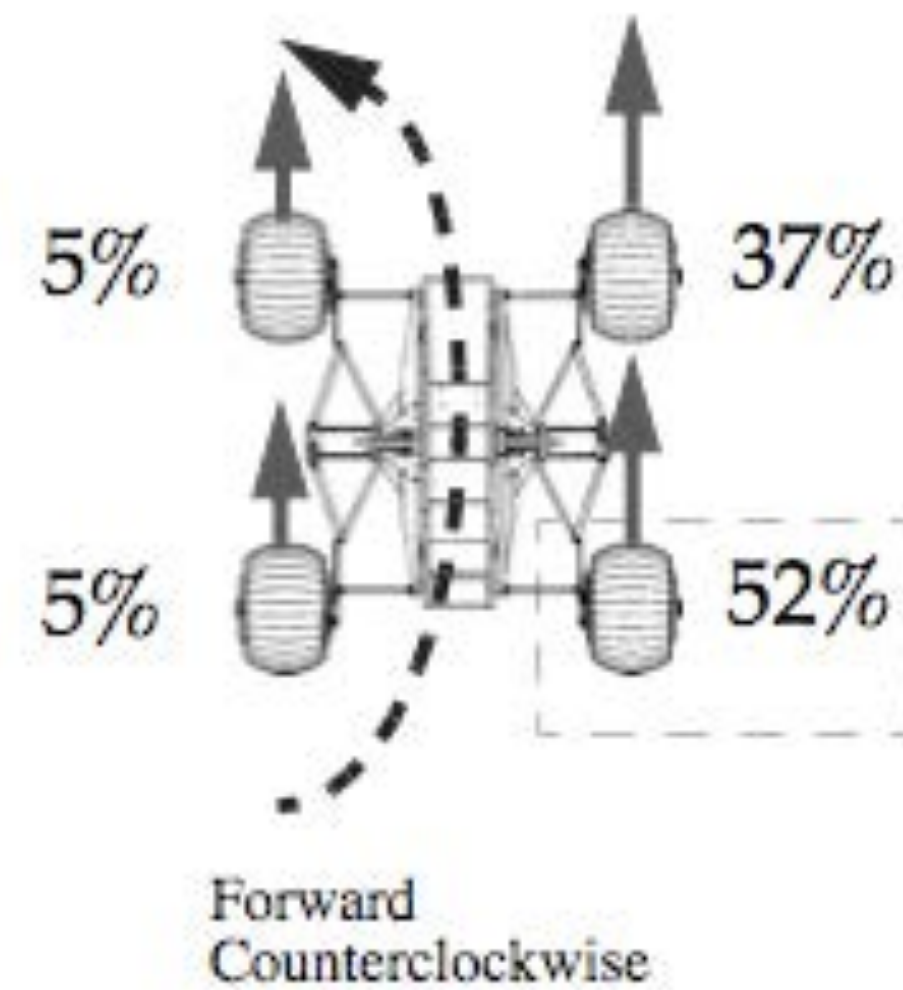
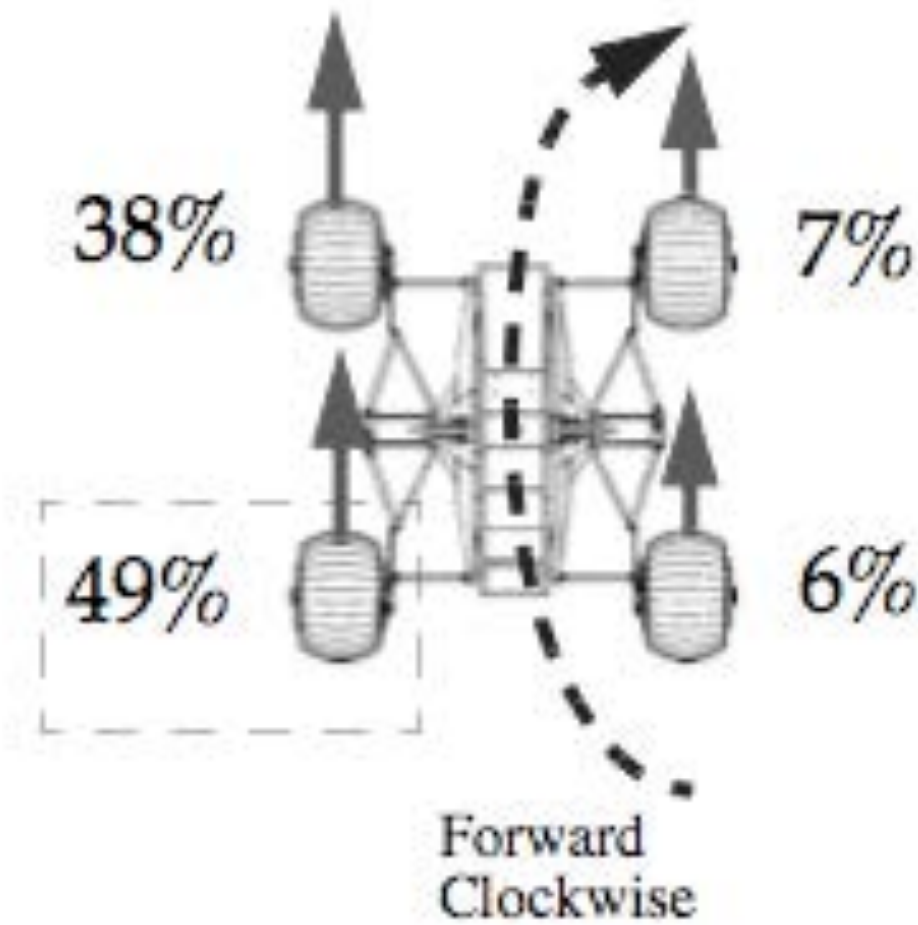

Split-Body Rovers (Sandia Labs)



Ratler (Sandia Labs)



Rocker-Bogie – Rocky 4



Rocky 7



Sojourner

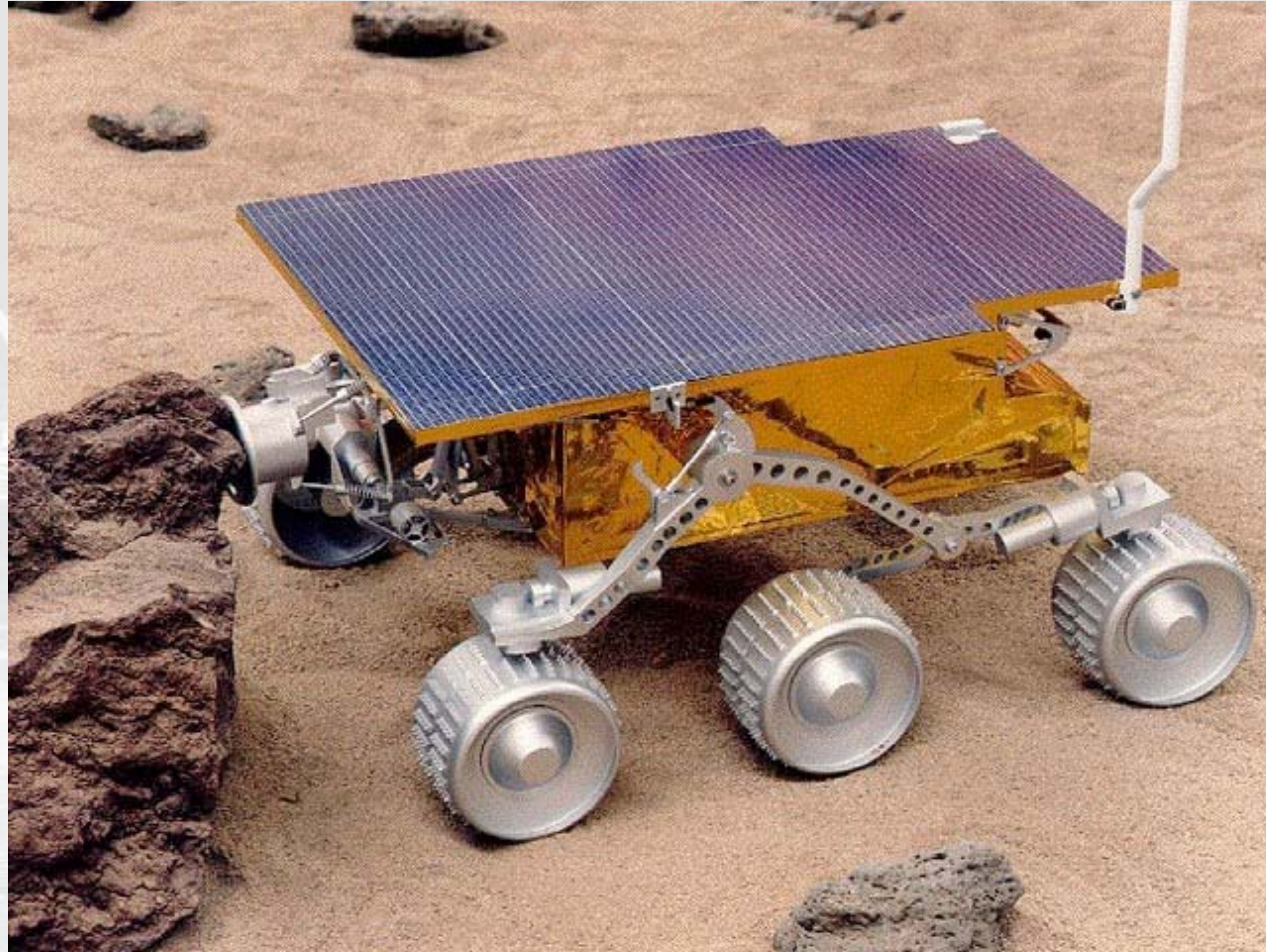

FIDO (JPL)

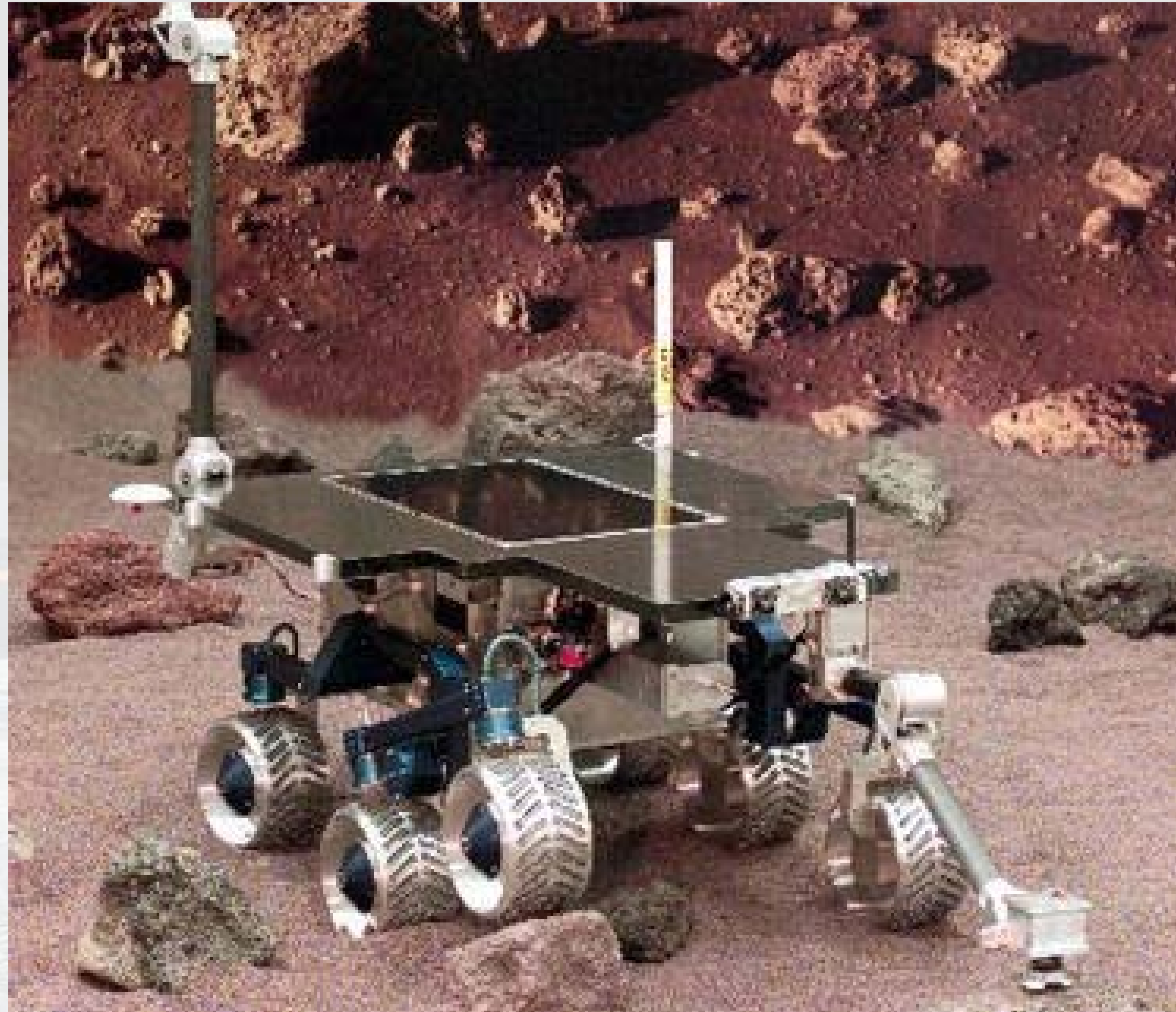

Mars Exploration Rover "Spirit"

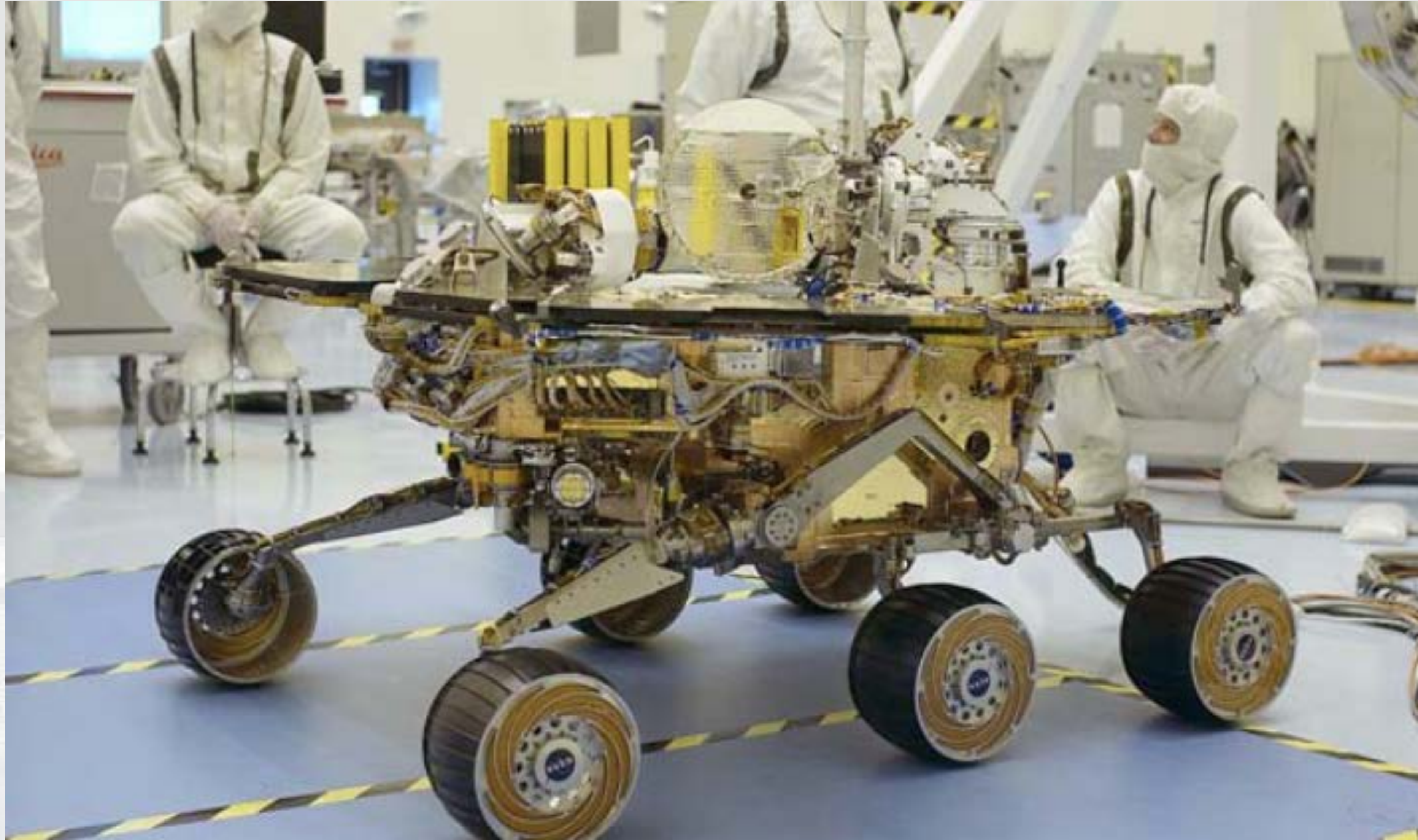

MER Rocker-Bogie Configuration

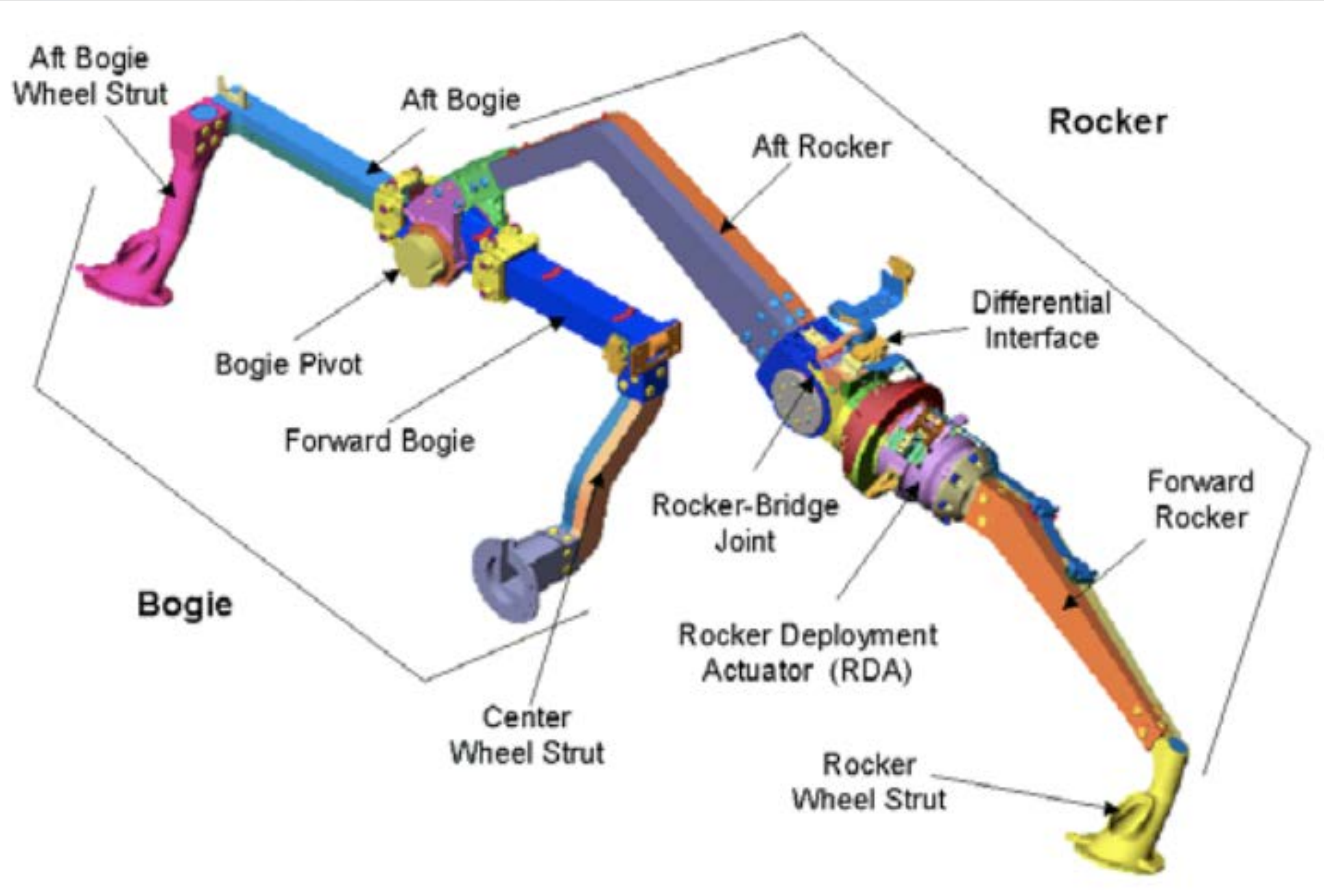

Lightweight Survivable Rover Dimensions

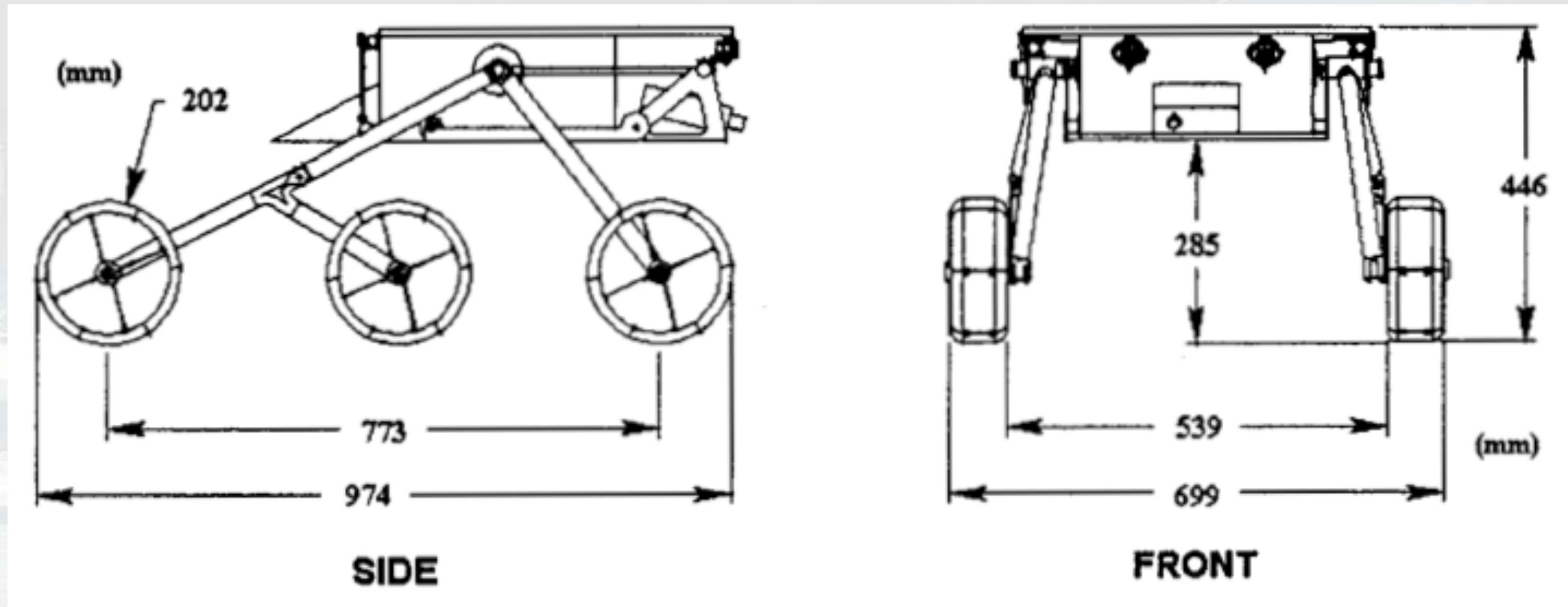

Mars Science Laboratory Development Unit



UNIVERSITY OF
MARYLAND

MSL Engineering Development Unit



UNIVERSITY OF
MARYLAND

K-Rex Rover (CMU for NASA Ames)



K-Rex Wheel Drive/Steering System

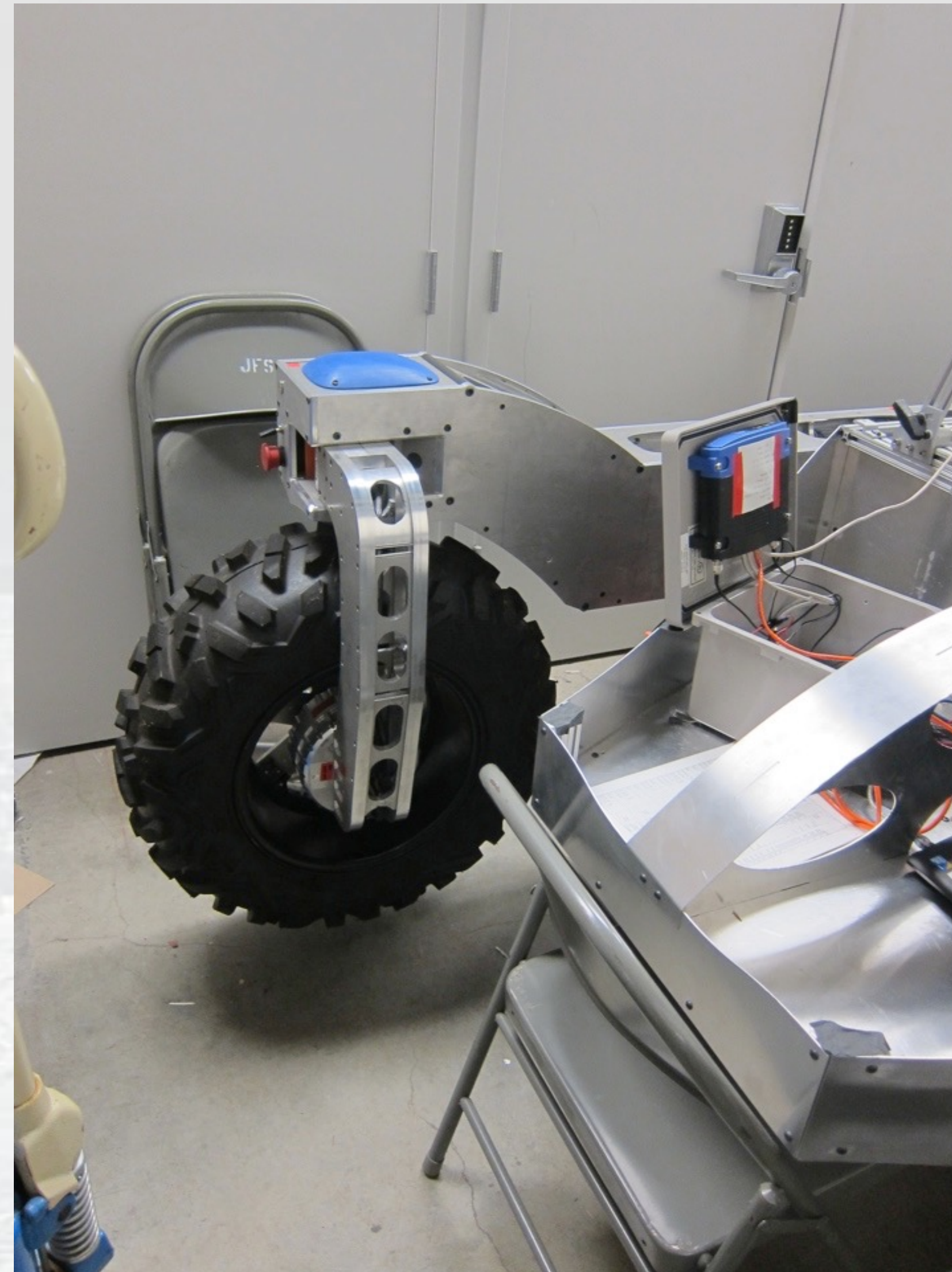

Lunar X-Prize (CMU)



Articulated Bogey Configuration



Segmented Body - Marsokhod

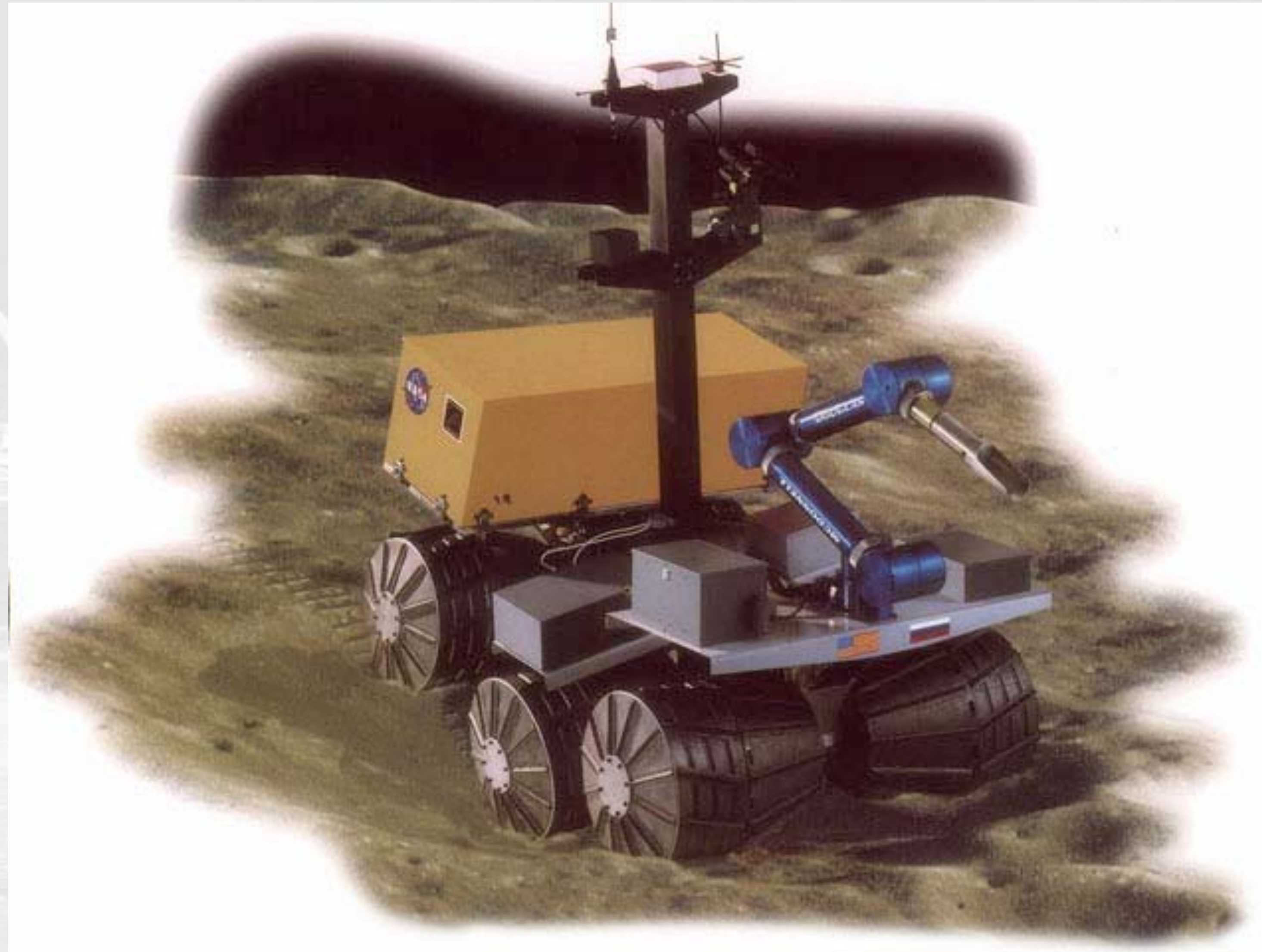

Marsokhod Chassis

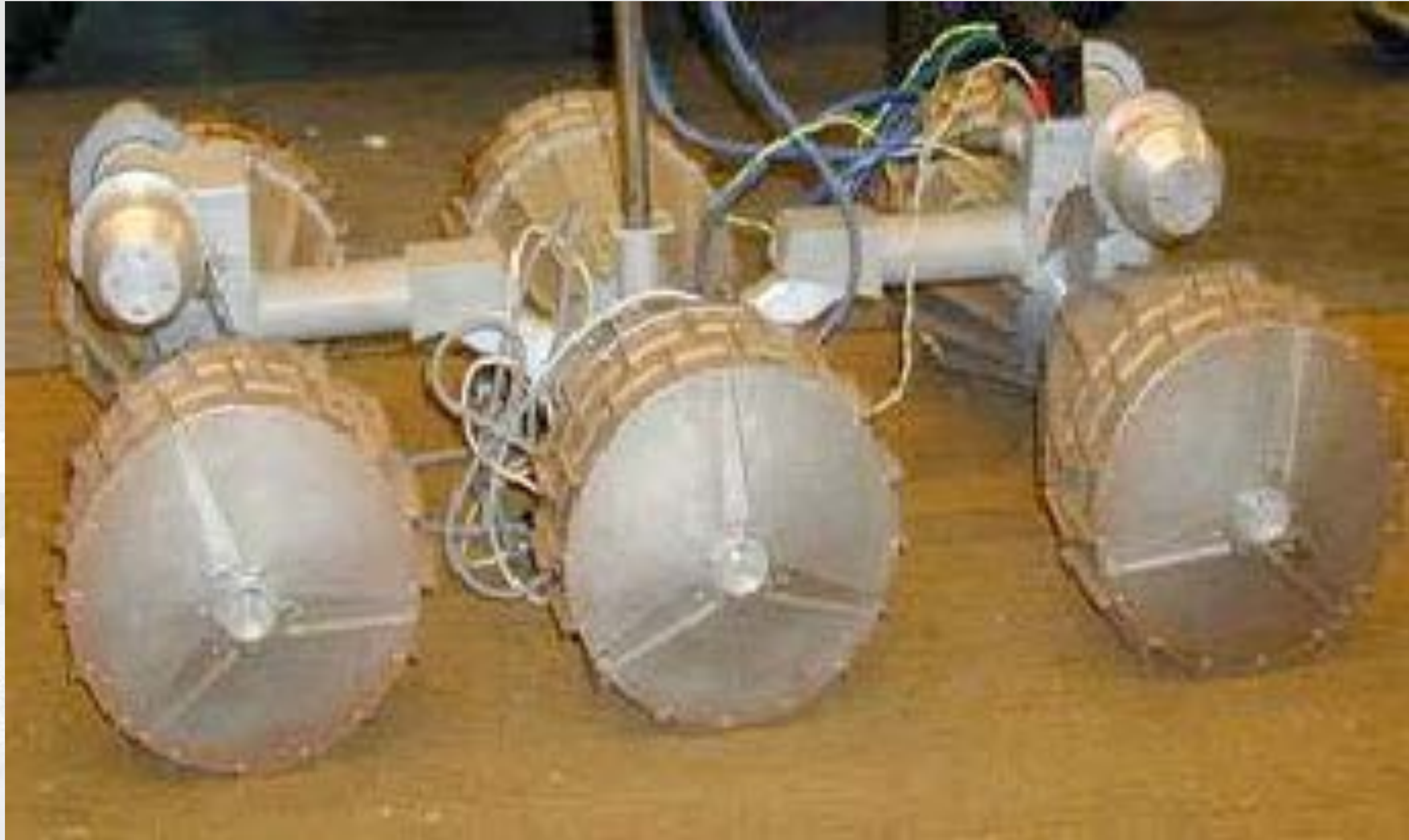

Robby (JPL)



SCARAB (CMU)



Scarab Wheel Articulation (CMU)

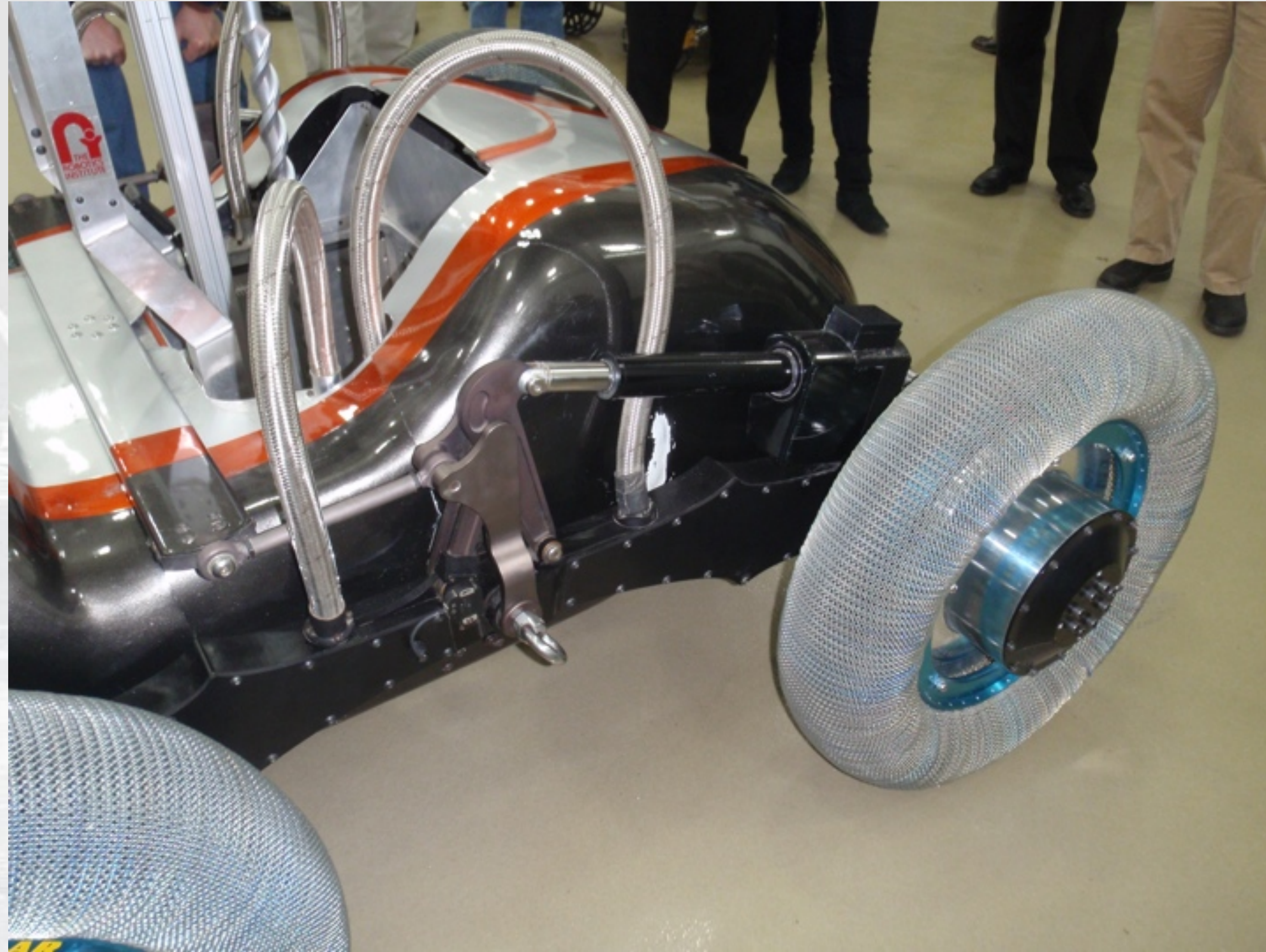

SCARAB at Full Extension (CMU)



Apollo Lunar Roving Vehicle

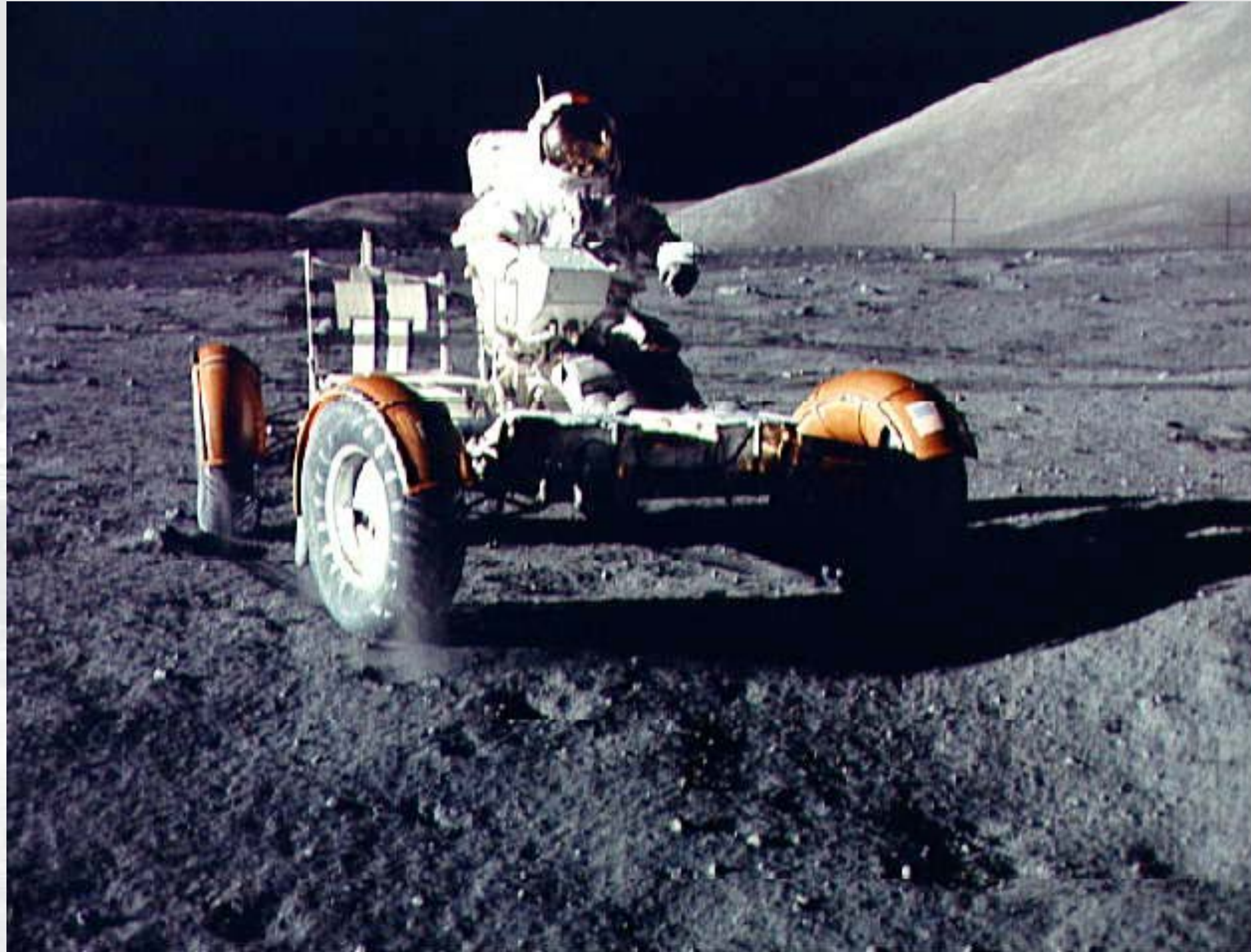

SCOUT Rover (JSC)



Electric Tractor and Chariot (JSC)



Active Suspension - Chariot



RAVEN in Field Trials



SEV Driving Onto $\sim 20^\circ$ Slope



SEV on $\sim 20^\circ$ Slope



SEV Dual Bogie Soil Contact



ATHLETE (JPL)



Centaur with Robonaut (JSC)



Centaur Body Pose and Turning



VERTEX Rover in BioBot Testing



VERTEX Steering/Suspension Configurations



Go-For (JPL)



Mars Rover (VNIITransmash - Russia)



Tessellator (CMU) (Holonomic)

