

**SPACE STATION PROGRAM
ANDROGYNOUS PERIPHERAL
ASSEMBLY SYSTEM TO
PRESSURIZED MATING ADAPTER
INTERFACE CONTROL DOCUMENT
PART 1 Core (APAS to PMA-2 & 3)**

International Space Station Program

October 30, 1998

Revision A



National Aeronautics and Space Administration

International Space Station Program

Johnson Space Center Houston, Texas

REVISION AND HISTORY PAGE

REV	DESCRIPTION	PUB DATE
-	Initial Release per VE-06	
-	Baseline Release per SSCD 000393, EFF. 01-06-97 (This baseline supersedes the Boeing initial release document dated April, 1995). (Note: Document SSP 42120, Part 1 Core APAS to PMA-2 & 3 original signatures apply to SSP 42120, Part 1, Appendix A for APAS to PMA-1).	02-28-97
A	Revision A per SSCD 001767, EFF. TBD (Incorporated PIRNS 42120-NA-0002 and 42120-NA-0003A)	

CONCURRENCE

**ANDROGYNOUS PERIPHERAL ASSEMBLY SYSTEM
TO PRESSURIZED MATING ADAPTER
INTERFACE CONTROL DOCUMENT PART 1**

30 OCTOBER 1998

PREPARED BY:	John H. Scott	NASA/JSC/ES
	PRINT NAME	ORGN
		7 August 1996
	SIGNATURE	DATE
APPROVED BY (NASA):	David Hamilton	NASA/JSC/EA4
	PRINT NAME	ORGN
	SIGNATURE	DATE
APPROVED BY (NASA):	Frank Monahan	NASA/JSC/OB
	PRINT NAME	ORGN
	SIGNATURE	DATE
REVIEWED BY (BOEING):	Greg Bohn	Prime/MDA
	PRINT NAME	ORGN
	SIGNATURE	DATE
SUPERVISED BY (BOEING):	Howard Griffin	Prime
	PRINT NAME	ORGN
	SIGNATURE	DATE

INTERNATIONAL SPACE STATION PROGRAM

DQA CONCURRENCE

**ANDROGYNOUS PERIPHERAL ASSEMBLY SYSTEM
TO PRESSURIZED MATING ADAPTER
INTERFACE CONTROL DOCUMENT PART 1**

30 OCTOBER 1998

PREPARED BY:	Robin Rainwater	OB5/Dynacs
	_____ PRINT NAME	_____ ORGN
	_____ SIGNATURE	_____ DATE
CHECKED BY (NASA):	Leasa Bulter	NASA/JSC/OB
	_____ PRINT NAME	_____ ORGN
	_____ SIGNATURE	_____ DATE
DQA:	Freddie G. Young	OB/Dynacs
	_____ PRINT NAME	_____ ORGN
	_____ SIGNATURE	_____ DATE

PREFACE

The contents of this document are intended to be consistent with the tasks and products to be prepared by Program participants. The Androgynous Peripheral Assembly System to Pressurized Mating Adapter Interface Control Document shall be implemented on all new ISS contractual and internal activities and shall be included in any existing contracts through contract changes. This document is under the control of the NASA Interface Control Working Group (ICWG), and any changes or revisions will be approved by the NASA ICWG chairman.

/s/ Denny Kross
Program Director (or designee),
International Space Station Program

11-13-96
Date

PRODUCT GROUP CONCURRENCE
SPACE STATION PROGRAM ANDROGYNOUS PERIPHERAL
ASSEMBLY SYSTEM TO PRESSURIZED MATING ADAPTER
INTERFACE CONTROL DOCUMENT PART 1
30 October 1998

Product Group-1 ICWG
Representative for Concurrence

Lee Archibald

PRINT NAME

SIGNATURE

DATE

CONCURRENCE

**SPACE STATION PROGRAM ANDROGYNOUS PERIPHERAL
ASSEMBLY SYSTEM TO PRESSURIZED MATING ADAPTER
INTERFACE CONTROL DOCUMENT PART 1
30 October 1998**

Manager,
Orbiter Project

J. H. Greene

PRINT NAME

SIGNATURE

DATE

PARAGRAPH	Page	
1.0	INTRODUCTION	1-1
1.1	PURPOSE & SCOPE	1-1
1.2	PRECEDENCE	1-1
1.3	RESPONSIBILITY AND CHANGE AUTHORITY	1-1
2.0	APPLICABLE DOCUMENTS	2-1
2.1	REFERENCE DOCUMENTS	2-3
3.0	PMA-2 & 3 TO PASSIVE APAS INTERFACES	3-1
3.1	GENERAL	3-1
3.1.1	INTERFACE DESCRIPTION	3-1
3.1.1.1	APAS DESCRIPTION	3-1
3.1.1.2	PMA DESCRIPTION	3-1
3.1.1.3	INTERFACE PLANE DESCRIPTION	3-1
3.1.1.4	COORDINATE SYSTEM	3-1
3.1.1.4.1	SPACE STATION	3-1
3.1.1.4.2	INTERFACING ELEMENTS	3-2
3.1.1.5	ENGINEERING UNITS	3-8
3.1.1.5.1	TOLERANCE	3-8
3.1.1.6	PASSIVE APAS INTERFACE FUNCTIONS	3-8
3.1.1.7	PMA-2 & 3 INTERFACE FUNCTIONS	3-8
3.1.2	INTERFACE RESPONSIBILITIES	3-8
3.1.2.1	RESPONSIBILITY FOR THE APAS	3-8
3.1.2.2	RESPONSIBILITY FOR PMA	3-8
3.2	INTERFACE REQUIREMENTS	3-9
3.2.1	PASSIVE ANDROGYNOUS PERIPHERAL ASSEMBLY SYSTEM (APAS) INTERFACE REQUIREMENTS	3-9
3.2.1.1	RESERVED	3-9
3.2.1.2	STRUCTURAL/MECHANICAL ATTACHMENT	3-9
3.2.1.2.1	STRUCTURAL LOADS AT THE INTERFACE PLANE	3-9
3.2.1.2.2	STRUCTURAL/MECHANICAL ATTACHMENT PROVISIONS	3-11
3.2.1.2.3	INTERCONNECTING UTILITY HARDWARE	3-11
3.2.1.2.4	STAY-OUT AND PASSAGEWAY ENVELOPES	3-11
3.2.1.2.5	ATOMSPHERIC SEALS	3-12
3.2.1.3	RESERVED	3-16
3.2.1.4	ELECTRICAL INTERFACES (SEE ISSUE)	3-16
3.2.1.4.1	VOLTAGE RATING	3-16
3.2.1.4.2	MAXIMUM CURRENT RATING	3-16
3.2.1.4.3	ELECTRICAL CONNECTORS	3-16
3.2.1.4.4	CABLE SPECIFICATIONS	3-16

PARAGRAPH	Page	
3.2.1.5	ELECTRONIC INTERFACES	3-16
3.2.1.5.1	DATA BUS INTERFACE	3-17
3.2.1.5.2	AUDIO INTERFACE	3-17
3.2.1.5.3	VIDEO INTERFACE	3-17
3.2.1.5.4	INSTRUMENTATION INTERFACE	3-18
3.2.1.5.5	ELECTRONIC CABLE SPECIFICATIONS	3-18
3.2.1.6	ENVIRONMENTS	3-19
3.2.1.6.1	ELECTROMAGNETIC COMPATIBILITY	3-19
3.2.1.6.2	THERMAL	3-29
3.2.1.6.3	VIBRO-ACOUSTIC	3-30
3.2.1.6.4	DEPRESSURIZATION	3-30
3.2.1.6.5	REPRESSURIZATION	3-30
3.2.2	PRESSURIZED MATING ADAPTER INTERFACE REQUIREMENTS	3-30
3.2.2.1	RESERVED	3-30
3.2.2.2	STRUCTURAL/MECHANICAL ATTACHMENT	3-30
3.2.2.2.1	STRUCTURAL LOADS AT THE INTERFACE PLANE	3-30
3.2.2.2.2	STRUCUTRAL/MECHANICAL ATTACHMENT PROVISIONS	3-31
3.2.2.2.3	INTERCONNECTING UTILITY HARDWARE	3-31
3.2.2.2.4	STAY-OUT AND PASSAGEWAYS ENVELOPES	3-32
3.2.2.2.5	ATMOSHPERIC SEALS	3-32
3.2.2.3	RESERVED	3-32
3.2.2.4	ELECTRICAL INTERFACES	3-32
3.2.2.4.1	VOLTAGE RATING	3-32
3.2.2.4.2	MAXIMUM CURRENT RATING	3-33
3.2.2.4.3	ELECTRICAL CONNECTORS	3-33
3.2.2.4.4	CABLE SPECIFICATIONS	3-33
3.2.2.5	ELECTRONIC INTERFACES	3-33
3.2.2.5.1	DATA BUS INTERFACE	3-33
3.2.2.5.2	AUDIO INTERFACE	3-33
3.2.2.5.3	VIDEO INTERFACE	3-34
3.2.2.5.4	INTRUMENTATION INTERFACE	3-34
3.2.2.5.5	ELECTRONIC CABLE SPECIFICATIONS	3-35
3.2.2.6	ENVIRONMENTS	3-35
3.2.2.6.1	ELECTROMAGNETIC EFFECTS	3-35
3.2.2.6.2	THERMAL	3-36
3.2.2.6.3	VIBRO-ACOUSTIC	3-36
3.2.2.6.4	DEPRESSURIZATION	3-36
3.2.2.6.5	REPRESSURIZATION	3-36

FIGURE	Page
3.1.1-1 APAS TO PRESSURIZED MATING ADAPTER 2 & 3 FUNCTIONAL INTERFACE DIAGRAM	3-3
3.1.1.3-1 ANDROGYNOUS PERIPHERAL ASSEMBLY SYSTEM (APAS) TO PRESSURIZED MATING ADAPTER STRUCTURAL/ MECHANICAL INTERFACE PLANE	3-4
3.1.1.3-2 PMA/APAS UTILITY INTERFACE PLANES	3-5
3.1.1.4.2-1 ANDROGYNOUS PERIPHERAL ASSEMBLY SYSTEM COORDINATE SYSTEM	3-6
3.1.1.4.2-2 PRESSURIZED MATING ADAPTER COORDINATE SYSTEM	3-7
3.2.1.2.4-1 APAS TO PMA STAY-OUT/PASSAGEWAY ENVELOPES	3-13
3.2.1.2.4-2 PMA/APAS CLEARANCE ENVELOPE-AXIAL VIEW	3-14
3.2.1.2.4-3 PMA/APAS CLEARANCE ENVELOPE-SIDE VIEW	3-15
3.2.1.6.1.2-1 LIMITS FOR CE01 AND CE02 NARROWBAND EMISSIONS	3-22
3.2.1.6.1.3-1 LIMITS FOR CE03 AND CE04 NARROWBAND EMISSIONS	3-23
3.2.1.6.1.4-1 LIMITS FOR CS01	3-24
3.2.1.6.1.4-2 LIMITS FOR CS01 ORBITER 28 VOLTS DC POWER	3-25
3.2.1.6.1.6-1 TRANSIENT SPIKE VOLTAGE	3-26
3.2.1.6.1.7.1-1 LIMITS FOR RE02 NARROWBAND EMISSIONS	3-27
3.2.1.6.1.7.2-1 LIMITS FOR RE02 BROADBAND EMISSIONS	3-28
 TABLE	
3.2.1.2.1.2 LAUNCH LIMIT LOAD FACTOR	3-9
3.2.1.2.1.3-1 APAS/PMA INTERFACE LOADS (ON-ORBIT)	3-10
3.2.1.2.1.3-2 LOADS SPECTRA FOR PRESSURIZED MATING ADAPTER/APAS	3-10
3.2.1.6.2.1-1 APAS DOCKING BASE TEMPERATURE AT APAS/PMA INTERFACE	3-29
3.2.2.2.1.2 LAUNCH LIMIT LOAD FACTORS (APAS ACCELERATIONS)	3-31

1.0 INTRODUCTION

1.1 PURPOSE & SCOPE

The purpose of this document is to provide definition of the structural/mechanical, electrical, environmental, communications, and data functional interface requirements between the Androgynous Peripheral Assembly System (APAS) mechanisms and the Pressurized Mating Adapter (PMA). Part I of this Interface Control Document (ICD) contains the design requirements for this interface; this Part II contains the design solutions for those requirements.

The scope of this document covers the interface between PMA-1, PMA-2, PMA-3, and the APAS. Henceforth, unless otherwise noted all references to PMA in the core section of this ICD are applicable to PMA-2 & 3, and all references to PMA in Appendix A of this ICD are applicable to PMA-1.

1.2 PRECEDENCE

In the event of conflict between SSP 41162, United States On-Orbit Segment (USOS) Specification and the contents of this ICD, the requirements of the ICD shall take precedence.

1.3 RESPONSIBILITY AND CHANGE AUTHORITY

The responsibility for assuring the definition, control, and implementation of the interfaces identified in this document is vested with the NASA ISS Program Office. This document will be formally approved and controlled in accordance with the provisions of document SSP 30459, International Space Station Interface Control Plan.

2.0 APPLICABLE DOCUMENTS

The documents in this paragraph are applicable to the extent specified herein. Inclusion of applicable documents herein does not in any way supersede the order of precedence identified in paragraph 1.2. The references show where each applicable document is cited in this document.

DOCUMENT NO.	TITLE
ASTME 380 Reference	Standard Practice for use of the International System of Units (SI) Section 4.5 Paragraph 3.1.1.5.1, A3.1.1.5.1
D684-10018-1 Reference	USOS Prime Contractor Interface Control Plan Paragraph 1.3
SSQ 21656 Reference	Wire and Cable, Electric, Fluoropolymer-Insulated, Nickel Coated Copper or Copper Alloy, General Specification For Paragraphs 3.2.2.5.2, A3.2.2.5.2
EIA-RS-259-C Reference	Rigid Coaxial Transmission Lines and Connections (video) Paragraphs 3.2.1.5.3, 3.2.2.5.3
NSTS 07700 Vol XIV Reference	Space Shuttle Systems Payload Accommodations Handbook Paragraphs 3.2.1.3.1.2, 3.2.2.3.1.2, A3.2.1.3.1.2, A3.2.2.3.1.2
NSTS-21000-IDD ISS Reference	Shuttle Orbiter/ISS Cargo Standard Interfaces Paragraphs 3.2.1.6.3, 3.2.2.6.3, A3.2.1.6.3, A3.2.2.6.3
ICD-A-21315- NODE 1 Reference	Shuttle Orbiter/Node 1 Cargo Element Interfaces Paragraphs 3.2.1.4, 3.2.2.4
SSP 30219 Reference	Space Station Reference Coordinate Systems Paragraphs 3.1.1.4.1, A3.1.1.4.1
SSP 30233 Reference	Problem Reporting and Corrective Action System Requirements for the Space Station Program Paragraphs 3.1.1.9, A3.1.1.9
SSP 30237 Reference	Space Station Electromagnetic Emission and Susceptibility Requirements for Electromagnetic Compatibility Paragraphs 3.2.2.6.1.2, A3.2.2.6.1.2

2.0 APPLICABLE DOCUMENTS (cont'd)

SSP 30240 Reference	Space Station Grounding Requirements Paragraphs 3.2.1.6.1.3, 3.2.1.6.1.4, 3.2.2.6.1.3, 3.2.2.6.1.4, A3.2.1.6.1.3, A3.2.1.6.1.4, A3.2.2.6.1.3, A3.2.2.6.1.4
SSP 30242 Reference	Space Station Cable/Wire Design and Control Requirements for Electromagnetic Compatibility Paragraphs 3.2.2.6.1.5, A3.2.1.6.1.5, A3.2.2.6.1.5
SSP 30243 Reference	Space Station System Requirements for Electromagnetic Compatibility Paragraphs 3.2.1.6.1.1, 3.2.1.6.1.6, 3.2.1.6.1.7, 3.2.2.6.1.1, 3.2.2.6.1.6, 3.2.2.6.1.7, A3.2.1.6.1.1, A3.2.1.6.1.6, A3.2.1.6.1.7, A3.2.2.6.1.1, A3.2.2.6.1.6, A3.2.2.6.1.7
SSP 30245 Reference	Space Station Electrical Bonding Requirements Paragraphs 3.2.1.6.1.4, 3.2.2.6.1.4, A3.2.1.6.1.4, A3.2.2.6.1.4
SSP 30426 Reference	Space Station Program External Contamination Control Requirements Paragraphs 3.1.1.9, A3.1.1.9
SSP 30482 Reference	Electrical Performance Specifications and Standards Volume 1 Paragraphs 3.2.1.6.1.2, 3.2.2.6.1.2, A3.2.1.6.1.2, A3.2.2.6.1.2
SSP 41162 Reference	United States On-Orbit Segment Specification Paragraph 1.2
SSP 50001 Reference	International Space Station Audio Standard Paragraphs 3.2.2.5.2.1, A3.2.2.5.2.1
SSP 50002 Reference	International Space Station Video Standard Paragraphs 3.2.2.5.3.1
SSP 50005 Reference	International Space Station Flight Crew Standard Paragraphs 3.2.2.3.3.2, A3.2.1.3.3.2, A3.2.2.3.3.2
SSP 50094	NASA/RSA Joint Specifications Standards Document for the ISS Russian Segment, Version 29 February 1996 (SEE ISSUE)
SSQ 21653 Reference	Paragraphs 3.2.1.5.4.3, 3.2.2.5.4.3

2.0 APPLICABLE DOCUMENTS (cont'd)

SSQ 21655	General Specification for Cable, Electrical, MIL-STD-1553B Data Bus, Space Quality
Reference	Paragraphs 3.2.1.5.4.1, 3.2.2.5.4.1, A3.2.1.5.4.1, A3.2.2.5.4.1
SSQ 21656	General Specification for Wire and Cable, Electric, Fluoropolymer-insulated, Nickel Coated Copper or Copper Alloy
Reference	Paragraphs 3.2.1.5.4.2, 3.2.2.5.4.2, A3.2.1.5.3.2, A3.2.2.5.3.2
SSQ 21678	General Specification for MIL-STD-1553B Switch
Reference	Paragraph 3.2.1.5.1.3

2.1 REFERENCE DOCUMENTS

JSC 26938A	Procurement Specification for the Androgynous Peripheral Docking
17 May 96	System for ISS Missions

Note that the APAS hardware is actually being built by RSC-Energia to the requirements baselined in this reference documentation. This ICD is written to be consistent with the interface design requirements of this reference document, but more detailed technical data may be found within it.

3.0 PMA-2 & 3 TO PASSIVE APAS INTERFACES

3.1 GENERAL

This section defines the functional interface requirements between the passive APAS and PMA-2 & 3. The functional interface requirements between the active APAS and PMA-1 are described in Appendix A of this document.

3.1.1 INTERFACE DESCRIPTION

The APAS/PMA interface consists of a bolted and sealed structural/mechanical interface, an electrical interface to support power transfer, an electronic interface to support instrumentation, data and audio/video transfer, and a passive thermal interface. The functional interface between the APAS and PMA-2 & 3 is shown in Figure 3.1.1-1, APAS to PMA-2 & 3 Functional Interface Diagram.

3.1.1.1 APAS DESCRIPTION

The APAS is a device which serves as part of the USOS to Orbiter interface. The APAS contains all of the passive components necessary to accomplish Orbiter to PMA mating operation. There is a pressure hatch on the APAS for PMA-2 & 3.

3.1.1.2 PMA DESCRIPTION

The PMA is a pressurable structural tunnel that utilizes the APAS to provide a structural interface with the Orbiter, and provide a shirt sleeve environment for transfer of crew and equipment between the Orbiter and the USOS.

3.1.1.3 INTERFACE PLANE DESCRIPTION

The APAS to PMA structural/mechanical interface plane lies on the PMA tunnel lower cylinder as shown in Figure 3.1.1.3-1, Androgynous Peripheral Assembly System to Pressurized Mating Adapter Structural/Mechanical Interface Plane. The structural/mechanical interface plane is defined at the $X_{PMA}=0$ plane. There are three utility interface planes, one is at the APAS junction box, one is on the APAS internal dome, and the other is at the top of the APAS resource umbilicals as shown in Figure 3.1.1.3-2, PMA/APAS Utility Interface Planes.

3.1.1.4 COORDINATE SYSTEM

3.1.1.4.1 SPACE STATION

The Space Station coordinate system is defined in SSP 30219, Space Station Reference Coordinate Systems.

3.1.1.4.2 INTERFACING ELEMENTS

The APAS coordinate system is shown in Figure 3.1.1.4.2-1, Androgynous Peripheral Assembly System Coordinate System. The PMA coordinate system is shown in Figure 3.1.1.4.2-2, Pressurized Mating Adapter Coordinate System.

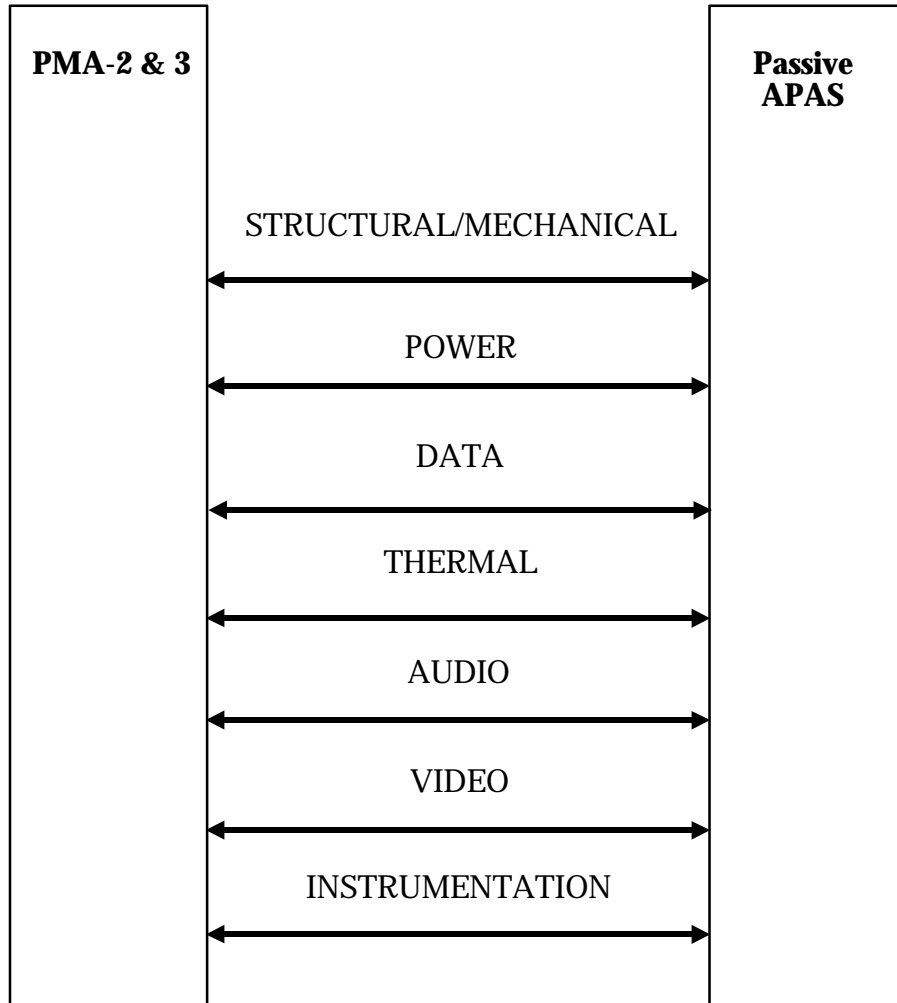
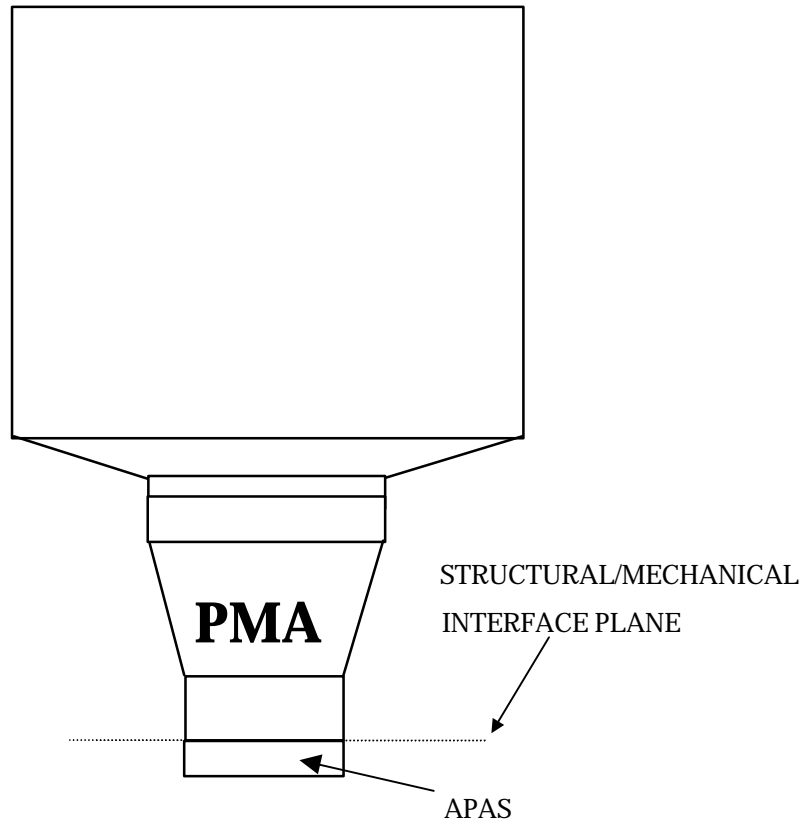

FIGURE 3.1.1-1 APAS TO PRESSURIZED MATING ADAPTER 2 & 3 FUNCTIONAL INTERFACE DIAGRAM



**FIGURE 3.1.1.3-1 ANDROGYNOUS PERIPHERAL ASSEMBLY SYSTEM (APAS)
TO PRESSURIZED MATING ADAPTER STRUCTURAL/ MECHANICAL INTERFACE
PLANE**

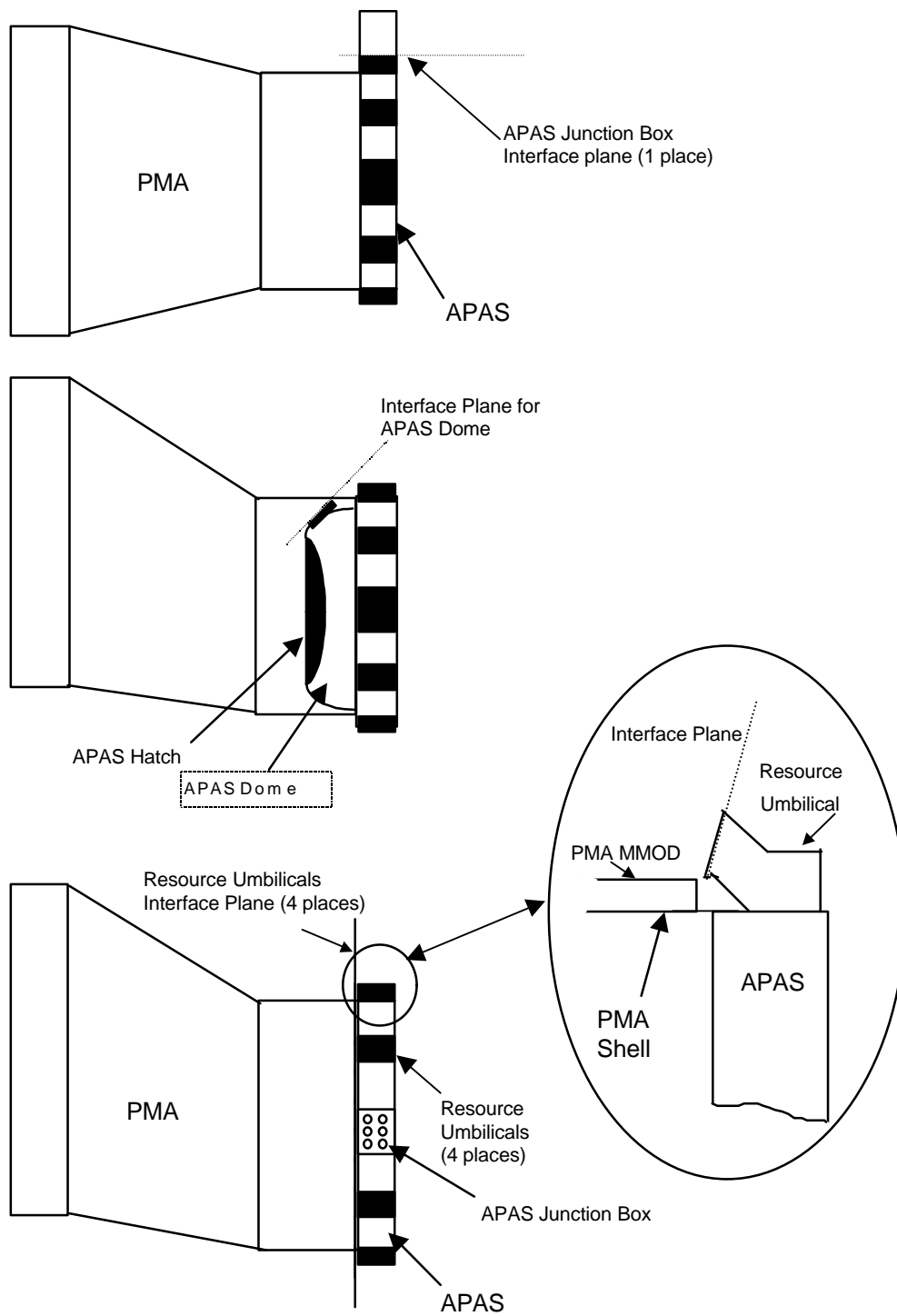
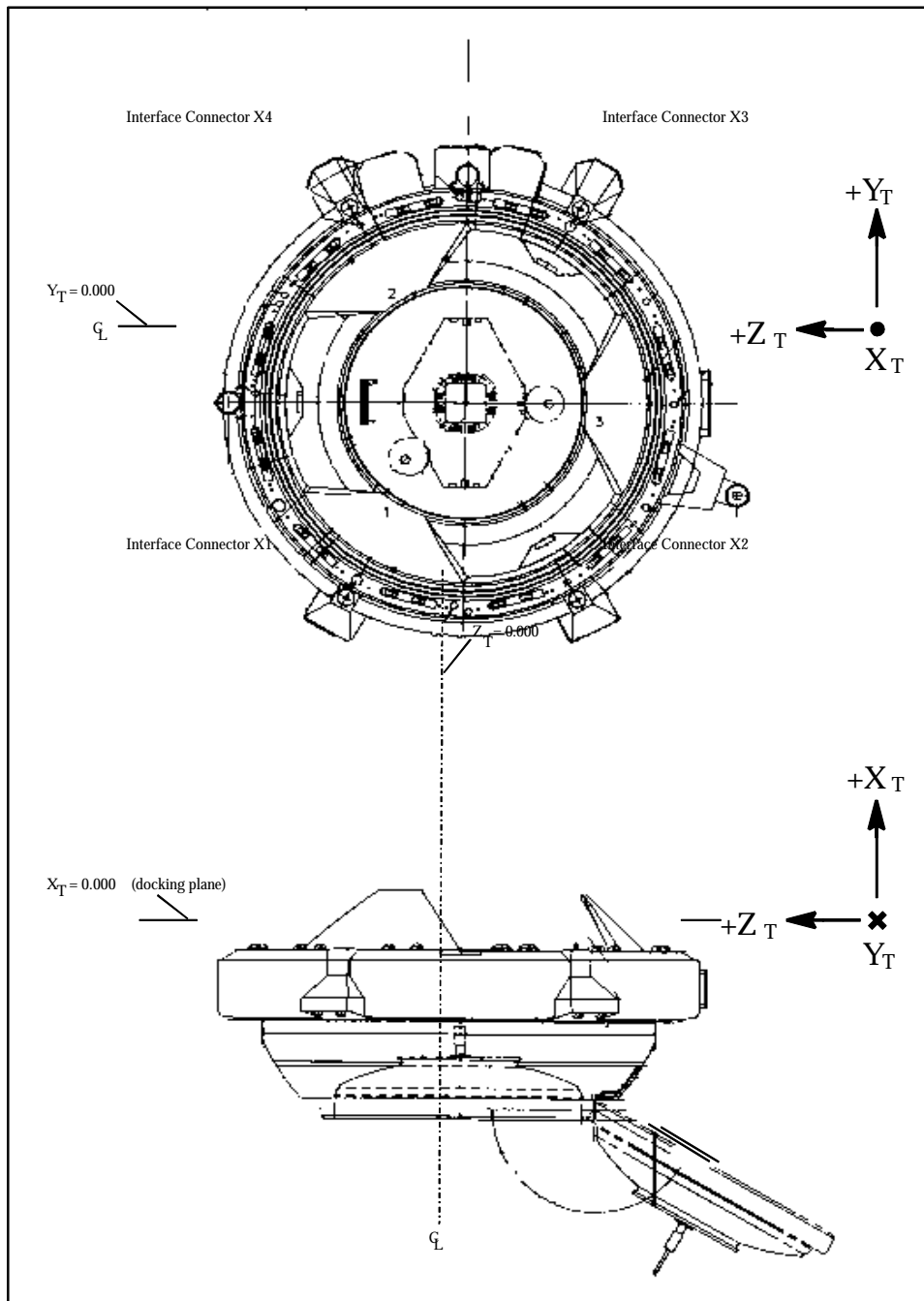

FIGURE 3.1.1.3-2 PMA/APAS UTILITY INTERFACE PLANES



**FIGURE 3.1.1.4.2-1 ANDROGYNOUS PERIPHERAL ASSEMBLY SYTEM
COORDINATE SYSTEM**

FIGURE 3.1.1.4.2-2 PRESSURIZED MATING ADAPTER COORDINATE SYSTEM

3.1.1.5 ENGINEERING UNITS

Dimensions in this document are shown in the English (inch, pound, second) system of units followed (where applicable) by the equivalent SI (metric) value in parenthesis. Measurements may be verified in either system of units.

3.1.1.5.1 TOLERANCE

Linear tolerances on English dimensions are $\pm .03$ and $\pm .010$ for two and three place decimal dimensions respectively. Linear tolerances on metric dimensions are derived from English measurements and tolerances as defined in ASTM E 380, Standard Practice for Use of the International System of Units (SI) (The Modernized Metric System), Section 4.5. Angular tolerances are $\pm 0.5^\circ$ on all angles unless otherwise stated.

3.1.1.6 PASSIVE APAS INTERFACE FUNCTIONS

The APAS supports structural/mechanical attachment to the PMA. The APAS supports the attachment of the following functions at the interface to PMA: power, data, audio, video, and instrumentation. The APAS shall support attachment of the APAS thermal blanket to the PMA.

3.1.1.7 PMA-2 & 3 INTERFACE FUNCTIONS

The PMA supports structural/mechanical attachment at the interface to APAS. The PMA supports the attachment of the following functions at the interface to APAS: power, data, audio, video and instrumentation. The PMA shall support the installation of the thermal blankets for the APAS.

3.1.2 INTERFACE RESPONSIBILITIES

Both the APAS and PMA shall conform to the interface controlled by this document.

3.1.2.1 RESPONSIBILITY FOR THE APAS

Unless otherwise noted herein, the National Aeronautics and Space Administration (NASA) carries the responsibility for designing to the interface requirements imposed on the APAS.

3.1.2.2 RESPONSIBILITY FOR PMA

Unless otherwise noted herein, McDonnell Douglas Aerospace (MDA) carries the responsibility for designing to the requirements imposed on the PMA.

3.2 INTERFACE REQUIREMENTS

3.2.1 PASSIVE ANDROGYNOUS PERIPHERAL ASSEMBLY SYSTEM (APAS) INTERFACE REQUIREMENTS

3.2.1.1 RESERVED

3.2.1.2 STRUCTURAL/MECHANICAL ATTACHMENT

3.2.1.2.1 STRUCTURAL LOADS AT THE INTERFACE PLANE

The APAS shall supply structural and mechanical provisions for mechanical attachment to the PMA in accordance with the loads defined below.

3.2.1.2.1.1 MATING IMPACT LOADS

The APAS to PMA mating loads are enveloped by the on-orbit pressure and transient interface loads described below.

3.2.1.2.1.2 LAUNCH LOADS

The APAS interface to the PMA shall survive NSTS launch loads using the load factors for liftoff and landing as defined in Table 3.2.1.2.1.2. These load factors shall be applied concurrently in all possible combinations at the APAS center of gravity.

TABLE 3.2.1.2.1.2 LAUNCH LIMIT LOAD FACTORS

DESCRIPTION	X (Gs)	Y (Gs)	Z (Gs)
PMA-2 APAS CG Liftoff	+1.23/-4.95	+1.97	+11.29
PMA-2 APAS CG Landing	+1.36	+1.28	+7.06/-3.47
PMA-3 APAS CG Liftoff	+0.93/-4.90	+3.19/-3.78	+3.46/-5.27
PMA-3 APAS CG Landing	+2.32/-2.38	+2.26/-2.58	+6.48/-1.57

3.2.1.2.1.3 ON-ORBIT PRESSURE AND INTERFACE LOADS

The APAS to PMA interface shall survive on-orbit pressurization loads for a maximum pressure of 16.0 psia (110.32 KPa) without loss of functionality as specified herein. The APAS to PMA interface shall be designed for the on-orbit interface loads of Table 3.2.1.2.1.3-1. The load components within each load case may be applied concurrently in any combination of positive and negative values for each component. The transient load spectrum associated with these interface load cases is defined in Table 3.2.1.2.1.3-2.

TABLE 3.2.1.2.1.3-1 APAS/PMA INTERFACE LOADS (ON-ORBIT)

	<i>Case 1</i>	<i>Case 2</i>	<i>Case 3</i>
Axial (lbf)	+/-1100	+/-1100	+/-3970
Shear (lbf)	+/-1100	+/-1100	+/-3310
Bending Moment (in-lbf)	+/-346,800	+/-577,000	+/-346,800
Torsion (in-lbf)	+/-577,000	+/-346,800	+/-346,800

Note: All loads for each case apply concurrently in any combination.
 Interface loads are defined at the PMA to Orbiter APAS mechanism interface.

TABLE 3.2.1.2.1.3-2 LOADS SPECTRA FOR PRESSURIZED MATING ADAPTER/APAS

Amplitude Tier %	Cycle Count
90-100	12
80-90	75
70-80	315
60-70	1,115
50-60	5,590
40-50	43,300
30-40	113,400
20-30	124,300
15-20	175,000
10-15	1,450,000
5-10	8,000,000
2.5-5	10,000,000

3.2.1.2.2 STRUCTURAL/MECHANICAL ATTACHMENT PROVISIONS

The passive APAS shall provide handling and alignment provisions for the mechanical attachment of the APAS to PMA.

The APAS hardware mounting and operation shall not interfere with any PMA hardware.

3.2.1.2.3 INTERCONNECTING UTILITY HARDWARE

The APAS interface shall incorporate provisions for the mechanical connection of power, data, instrumentation, video, and audio utilities between the PMA and APAS.

3.2.1.2.3.1 ACCESSIBILITY

The external utility interface is not designed for accessibility by EVA-suited crew members. The internal utility interface design shall comply with SSP 50094, paragraph 6.4.5, Connector Design Requirements (for internal connectors).

3.2.1.2.3.2 REDUNDANCY

The APAS shall accommodate redundant utility interfaces for APAS and PMA Command and Data Handling (C&DH) Buses and primary and secondary power connections. Alternate or redundant functional paths shall be separated or protected at the interface such that a credible event which causes the loss of one functional path will not result in the loss of the alternate or redundant functional path(s).

3.2.1.2.4 STAY-OUT AND PASSAGEWAYS ENVELOPES

Two stay-out envelopes are needed at this interface. One stayout envelope is needed external to the PMA/APAS structure for installation of the PMA micrometeoroid/orbital debris (MM/OD) shield and to clear PMA ground support equipment. An internal access envelope is needed at the interface for APAS hatch clearance and internal utility connector access. The APAS to PMA stay-out and passageway envelopes shall be as shown in Figure 3.2.1.2.4-1, APAS to PMA Stay-out/Passageway Envelope, Figure 3.2.1.2.4-2, PMA/APAS Clearance Envelope-Axial View, and Figure 3.2.1.2.4-3, PMA/APAS Clearance Envelope-Side View.

3.2.1.2.5 ATMOSPHERIC SEALS

The APAS shall provide pressure seals at the APAS to PMA interface.

3.2.1.2.5.1 LEAKAGE

The APAS to PMA interface shall not exceed 5×10^{-4} sccs leakage at 14.9 psi (102 KPa) averaged over a 24 hour period.

3.2.1.2.6 APAS THERMAL BLANKETS

The APAS shall provide attachment provisions to facilitate installation of the APAS thermal blanket on the PMA debris shield after installation of the APAS on the PMA.

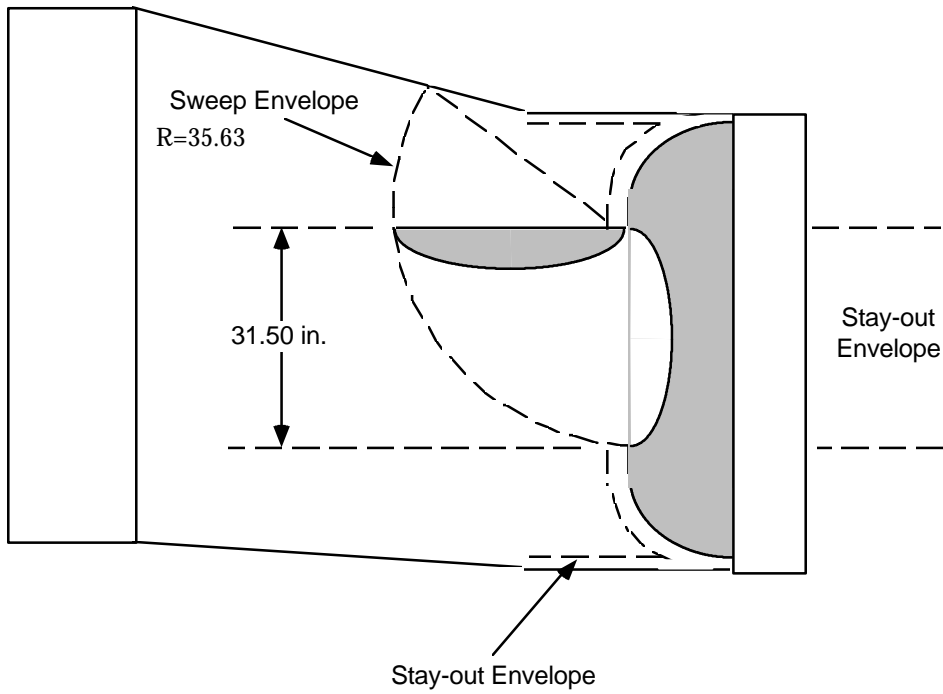

FIGURE 3.2.1.2.4-1 APAS TO PMA STAY-OUT/PASSAGEWAY ENVELOPES

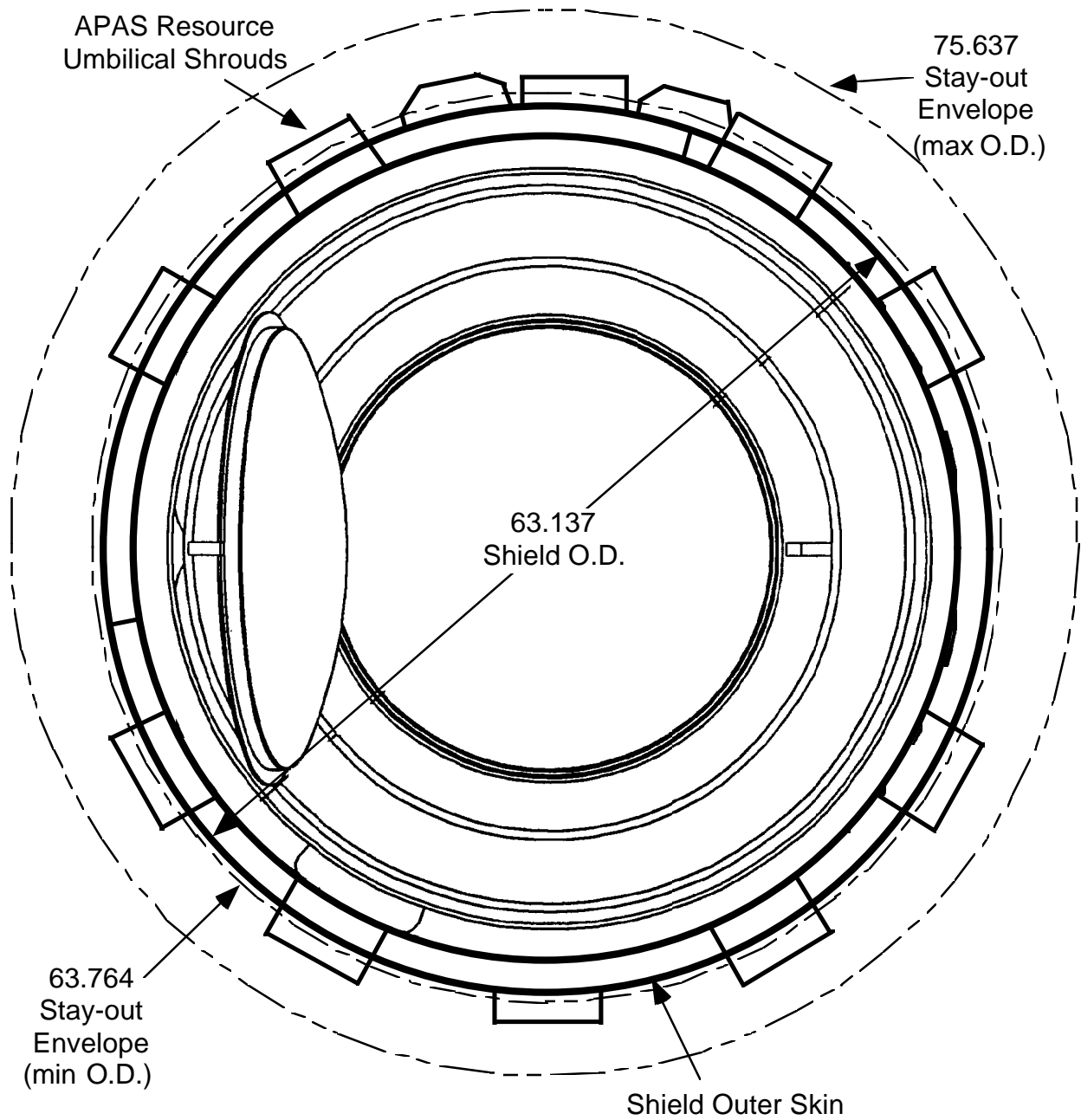

FIGURE 3.2.1.2.4-2 PMA/APAS CLEARANCE ENVELOPE-AXIAL VIEW

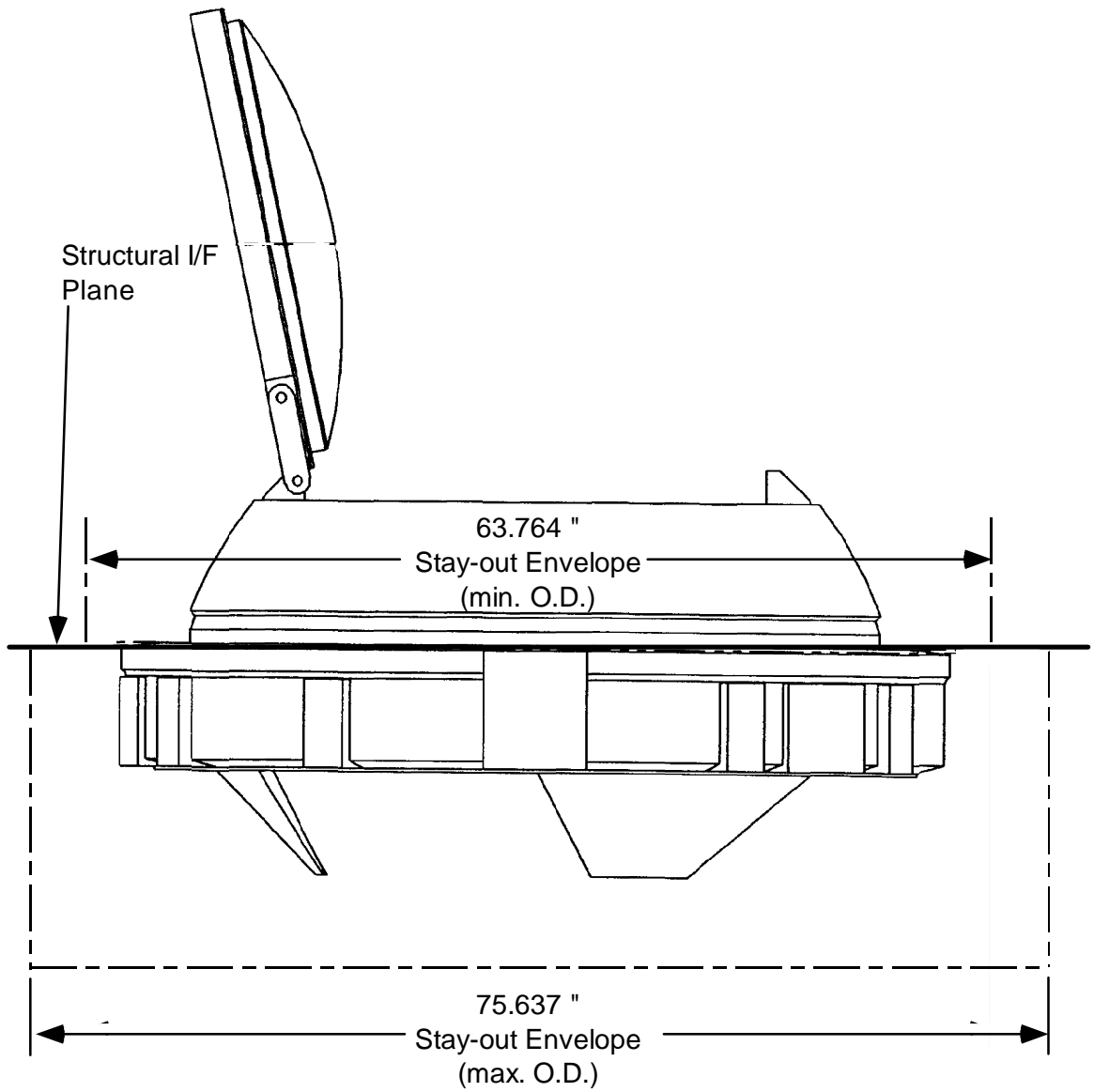

FIGURE 3.2.1.2.4-3 PMA/APAS CLEARANCE ENVELOPE-SIDE VIEW

3.2.1.3 RESERVED

3.2.1.4 ELECTRICAL INTERFACES

The APAS interface to PMA shall provide two feeds for the transfer of electrical power to the PMA at a nominal 140 VDC, two feeds for the transfer of electrical power routed back to the PMA-2/3 APAS hook motors, and one feed for operating the PMA-1 active APAS. This electrical power shall have interface parameters and characteristics in accordance with the requirements of ICD-A-21315-NODE 1, Shuttle/Orbiter/Node 1 Cargo Element Interfaces, and NSTS-21000-IDD-ISS.

3.2.1.4.1 VOLTAGE RATING

The power interface shall provide for a maximum potential of 165 VDC continuous and a maximum of 180 VDC transient for up to 10 msec.

3.2.1.4.2 MAXIMUM CURRENT RATING

The secondary power interface shall provide for a maximum current of 35 amperes.

3.2.1.4.3 ELECTRICAL CONNECTORS

The electrical connectors shall have voltage and current carrying capability consistent with the requirements specified above.

3.2.1.4.4 CABLE SPECIFICATIONS

The physical characteristics of power utility cables shall be in accordance with the requirements of SSP 50094, paragraph. 3.4.6.

3.2.1.5 ELECTRONIC INTERFACES

The passive APAS shall supply the capability for connector and clamp attachment and the passage of electronic media consisting of data, audio, and video at the PMA/APAS interface.

3.2.1.5.1 DATA BUS INTERFACE

3.2.1.5.1.1 DATA BUS STANDARD

The electrical characteristics and data transfer protocol for the C&DH MIL-STD-1553 interface shall conform to the requirements specified in NSTS-21000-IDD-ISS, paragraphs 8.1.4.2.1.3 and 9.4.3.

3.2.1.5.1.2 INTERFACE BUSES

At any one time during the assembly phase of the ISS, the APAS-disconnect-panel-to-PMA interface shall accommodate the transfer of signals for two separate data buses to either PMA-2 or PMA-3. Each bus shall be provided with dual redundant data paths across the interface. The data path interfaces for each bus shall conform to the redundancy requirements given in paragraph 3.2.1.2.3.2. Selection of the data buses to be transferred across these paths shall be in accordance with NSTS-21000-IDD-ISS, paragraph 9.4.3.

3.2.1.5.1.3 DATA BUS SWITCHING

The APAS shall provide interfaces for MIL-STD-1553 local bus switching to loop the bus back automatically when the orbiter is not present. At any one time during the assembly phase of the ISS, this interface shall accommodate the automatic loop back of both data paths available at PMA-2 or PMA-3. The data path interfaces for each loop back shall conform to the redundancy requirements given in paragraph 3.2.1.2.3.2. Data bus switches, supplied by the PMA contractor, shall have characteristics as specified in SSQ 21678.

3.2.1.5.2 AUDIO INTERFACE

3.2.1.5.2.1 AUDIO STANDARD

The APAS shall perform audio data exchange with the PMA in accordance with the standards defined in NSTS-21000-IDD-ISS, paragraph 8.1.1.

3.2.1.5.2.2 HARDWIRED AUDIO

The APAS-to-PMA interface shall support two-way audio communications. This interface shall accommodate up to ten (10) hardwired audio signals to and from the PMA.

3.2.1.5.3 VIDEO INTERFACE

3.2.1.5.3.1 VIDEO STANDARD

The APAS shall perform video data exchange with the PMA in accordance with the standards defined in NSTS-21000-IDD-ISS, paragraph 8.1.2.

3.2.1.5.3.2 HARDWIRED VIDEO

The APAS-to-PMA interface shall support two-way video communications. This interface shall distribute three (3) hardwired video signals to and from the PMA.

3.2.1.5.4 INSTRUMENTATION INTERFACE

3.2.1.5.4.1 ACS MODING INSTRUMENTATION

The APAS-to-PMA interface shall transfer instrumentation signals to the PMA for Attitude Control System (ACS) moding. This interface shall transfer signals from twelve (12) capture indicators, six (6) interface sealed indicators, and four (4) undocking complete indicators. The contact resistance of these indicators at the APAS-to-PMA interface shall be 1.5 ohms maximum at 0.1 mA and 15 Vdc.

3.2.1.5.4.2 TEMPERATURE SENSOR INSTRUMENTATION

The APAS-to-PMA interface shall transfer instrumentation signals to the PMA for temperature sensing. This interface shall transfer signals from four (4) temperature sensors. The contact resistance of these sensors at the APAS-to-PMA interface shall be 1.5 ohms maximum at 0.1 mA and 15 Vdc.

3.2.1.5.4.3 HOOK MOTOR INSTRUMENTATION

The APAS-to-PMA interface shall transfer instrumentation signals to the PMA for Hook Motor and Hook Closed indications. This interface shall transfer signals from eight (8) Hook Motor indicators (in two places) and four (4) Hook Closed indicators (in two places) to be looped back into the APAS for distribution.

3.2.1.5.4.4 PMA-1 ACTIVE APAS INSTRUMENTATION

The APAS shall transfer instrumentation signals to the PMA for the operation of the PMA-1 active APAS as specified in JSC 26938, Procurement Specification for the APDS for the ISS Missions.

3.2.1.5.5 ELECTRONIC CABLE SPECIFICATIONS

The physical characteristics of all APAS electronic cables shall be in accordance with the requirements of SSP 50094, paragraph 3.4.6.

3.2.1.6 ENVIRONMENTS

3.2.1.6.1 ELECTROMAGNETIC COMPATIBILITY

3.2.1.6.1.1 GENERAL

This section contains the limits for which the APAS will be certified. Where both Orbiter and ISS electromagnetic environments are applicable, only the more severe of the two is imposed on the APAS. Equipment emitting both broadband and narrowband signals at the same frequency shall meet both requirements.

3.2.1.6.1.2 LIMITS FOR CE01 AND CE02

Electromagnetic emission in the frequency range of 30 Hz to 20 kHz shall not appear on power leads, control leads, signal leads, and interconnecting cables between parts, sources and loads of an equipment in excess of the values shown on Figure 3.2.1.6.1.2-1. Only leads going external to the subsystem/equipment shall be considered. Intentional transmissions by conduction on signal leads are exempt.

3.2.1.6.1.3 LIMITS FOR CE03 AND CE04

Electromagnetic emissions in the frequency range of 20 kHz to 50 MHz shall not appear on power leads, control leads, signal leads, and interconnecting cables between parts, sources and loads of an equipment in excess of the values shown on Figure 3.2.1.6.1.3-1. Only leads going external to the subsystem/equipment shall be considered. Intentional transmissions by conduction on signal leads are exempt.

3.2.1.6.1.4 LIMIT FOR CS01

The performance characteristics of the subsystem/equipment shall not be degraded beyond the tolerances given in the individual equipment specification or approved test plan, in the frequency range of 30 Hz to 50 kHz, when subjected to electromagnetic energy injected on its power leads equal to or less than the values shown on Figure 3.2.1.6.1.4-1. The reduced limits of Figure 3.2.1.6.1.4-2 shall apply to equipment powered from the Orbiter +28 Vdc source.

3.2.1.6.1.4.1 TEST POWER LIMIT

The requirements for this test are also met if the required voltages cannot be generated by 50 watts dissipated into a 0.5 ohm load and the test sample is not susceptible to the lower voltage 50 watt source output setting.

3.2.1.6.1.5 LIMIT FOR CS02

The performance characteristics of subsystems and equipment shall not be degraded beyond the tolerances given in the individual equipment specification or approved test plan, in the frequency range of 50 kHz to 400 MHz, when subjected to 1 volt from a 50-ohm source applied to the equipment power input terminals (excluding power cable). The limit shall be 0.22 volt for equipment powered from the Orbiter +28 Vdc source.

3.2.1.6.1.5.1 TEST POWER LIMIT

When a one-watt source of 50-ohm impedance cannot develop the required voltage at the equipment power-input terminals (excluding power cable) and the equipment is not susceptible to the output of this signal source, then the equipment may be considered non-susceptible.

3.2.1.6.1.6 LIMIT FOR CS06

The equipment shall not exhibit any malfunction, degradation of performance or deviation from specified indication beyond the tolerances given in the equipment specification or approved test plan when the spike shown on Figure 3.2.1.6.1.6-1 is applied to the dc power input lines of the equipment.

3.2.1.6.1.7 LIMITS FOR RE02

3.2.1.6.1.7.1 NARROWBAND

Narrowband E-field emissions in the frequency range of 14 kHz to 15 GHz shall not be generated and radiated in excess of the values shown in Figure 3.2.1.6.1.7.1-1.

3.2.1.6.1.7.2 BROADBAND

Continuous or repetitive broadband E-field emissions shall not be generated and radiated in excess of the values shown in Figure 3.2.1.6.1.7.2-1. Broadband E-field emissions resulting from equipment turn on/off and switching transients are exempt from this requirement. Switching transient requirements are covered by the time domain transient and ripple test described in 3.2.1.6.1.10.

3.2.1.6.1.7.3 POLARIZATION

In the frequency range of 25 to 200 MHz, the limit shall be met for both horizontally and vertically polarized waves.

3.2.1.6.1.8 LIMIT FOR RS02

The equipment shall not exhibit any malfunction, degradation of performance, or deviation from specified indication beyond tolerances given in the equipment specification or approved test plan when subjected to the following fields:

a. Power Frequency Test. Twenty (20) amperes applied to the input wire at the power frequency (ies).

b. Spike Test. The same spike shape shown in Figure 3.2.1.6.1.6-1 where E = 100 volts across 5 ohms applied to the input wire.

3.2.1.6.1.9 LIMIT FOR RS03

The equipment shall not exhibit any malfunction, degradation of performance, or deviation, from specified indications beyond the tolerances indicated in the equipment or subsystem specification when subjected to the radiated electric fields less than or equal to those specified herein. Above 30 MHz, the requirement shall be met for both horizontally and vertically TBD polarized waves. As a minimum, the levels below apply at either the specific frequencies stated or across the ranges stated:

Frequency/Range	Radiated Electric Field Level
14kHz-200MHz	5 V/m
200MHz-8GHz	60 V/m
8GHz -10GHz	20 V/m
2.2GHz	161 V/m
8.5GHz	79 V/m
13.7GHz-15.2GHz	250 V/m

3.2.1.6.1.10 GROUNDING

APAS equipment shall meet bonding requirements specified in SSP 50094, paragraph 3.4.8.

3.2.1.6.1.11 BONDING

The APAS shall provide accommodations for a class R bond with the PMA.

3.2.1.6.1.12 CABLE AND WIRE DESIGN

The APAS cables and wires shall meet the requirements of SSP 50094, paragraph 3.4.6.

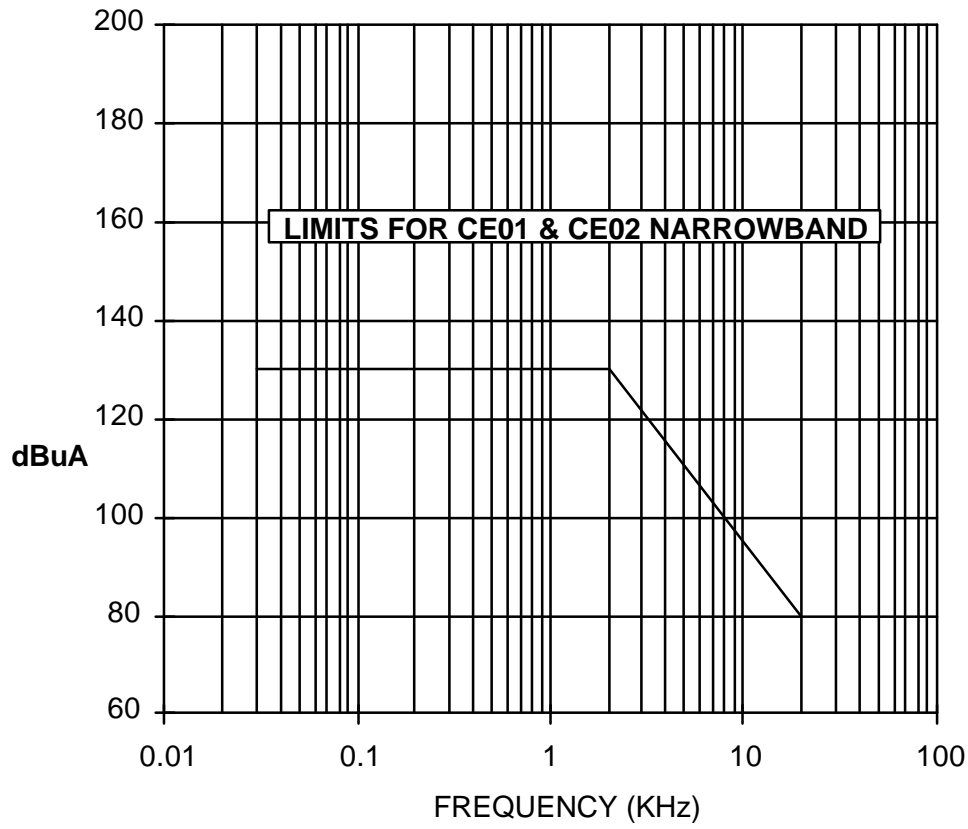

FIGURE 3.2.1.6.1.2-1. LIMITS FOR CE01 AND CE02 NARROWBAND EMISSIONS

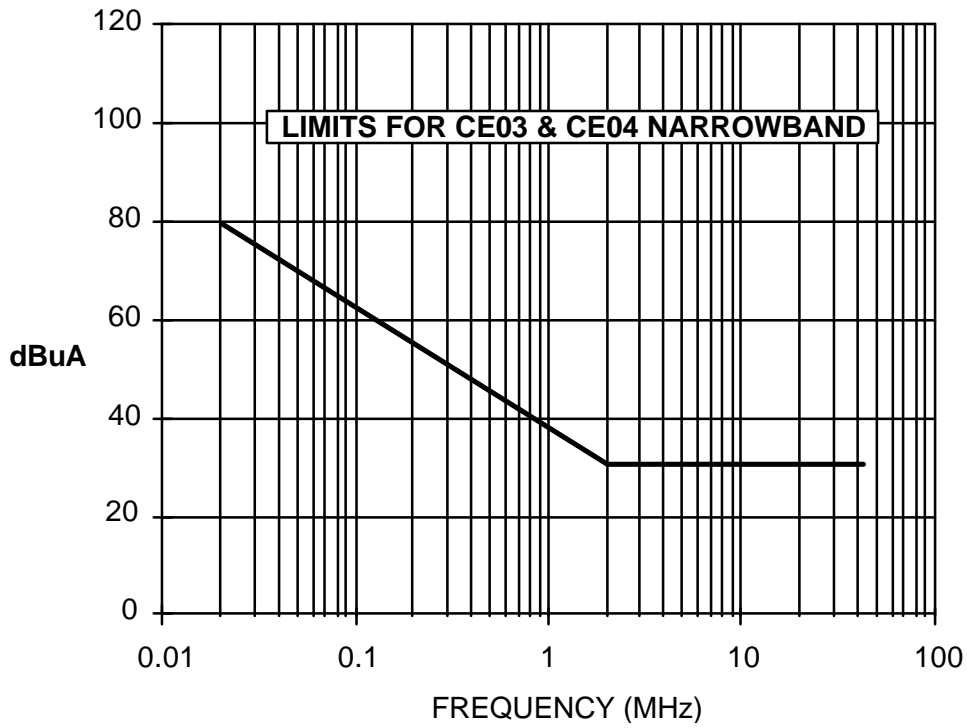

FIGURE 3.2.1.6.1.3-1. LIMITS FOR CE03 AND CE04 NARROWBAND EMISSIONS

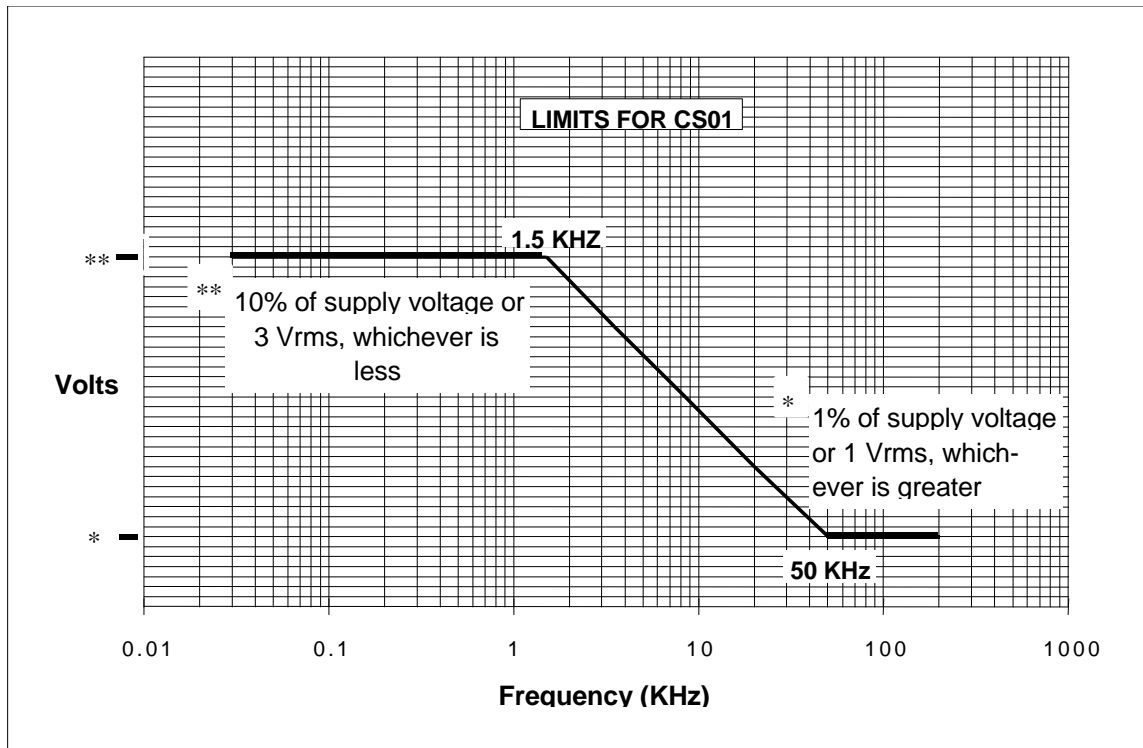

FIGURE 3.2.1.6.1.4-1 LIMITS FOR CS01

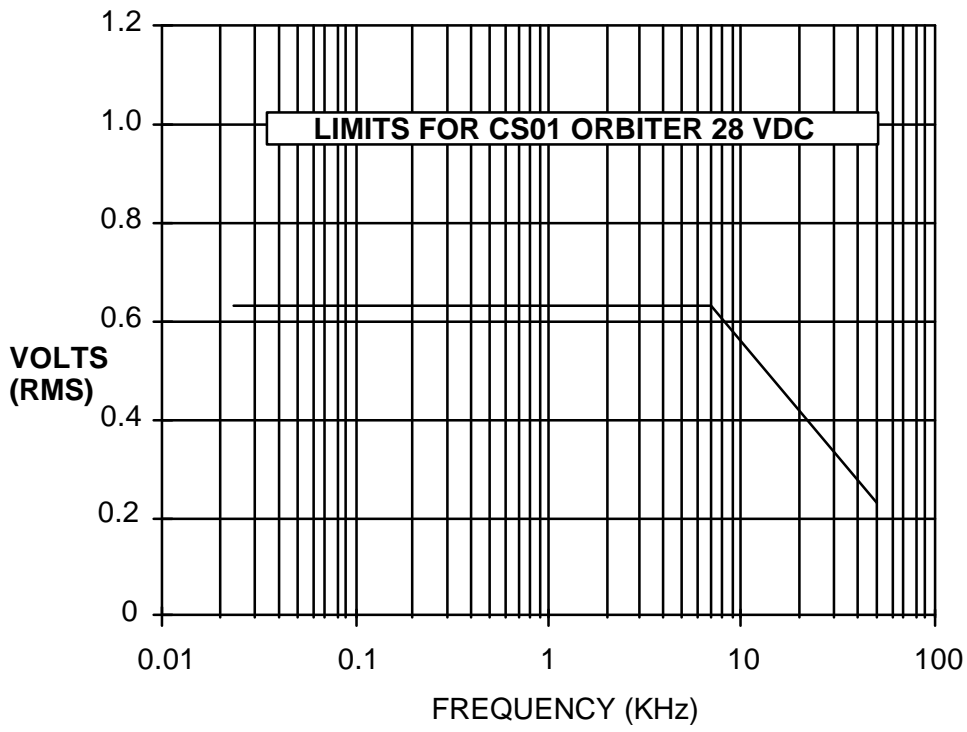

FIGURE 3.2.1.6.1.4-2 LIMITS FOR CS01 ORBITER 28 VOLTS DC POWER

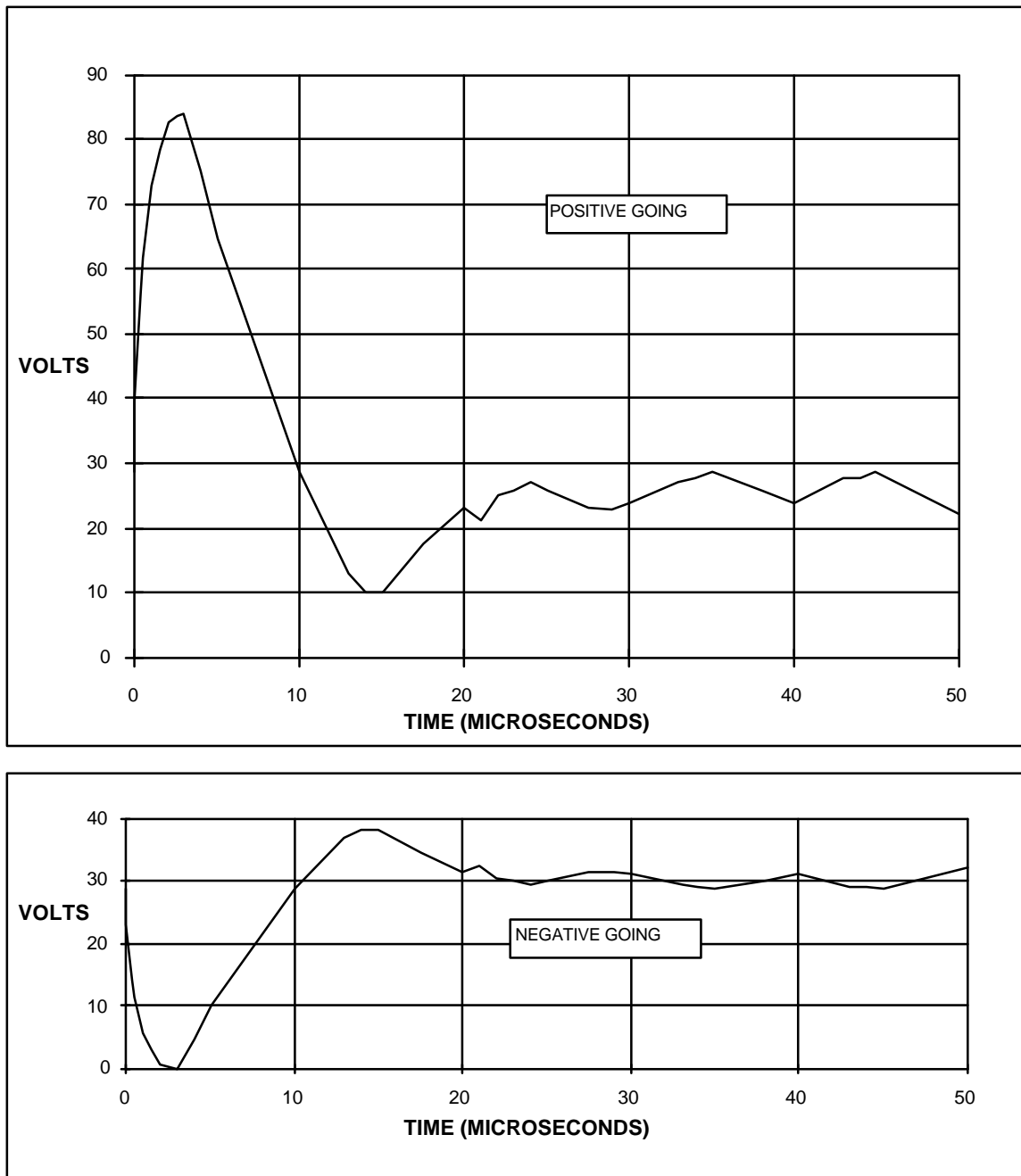

FIGURE 3.2.1.6.1.6-1 TRANSIENT SPIKE VOLTAGE

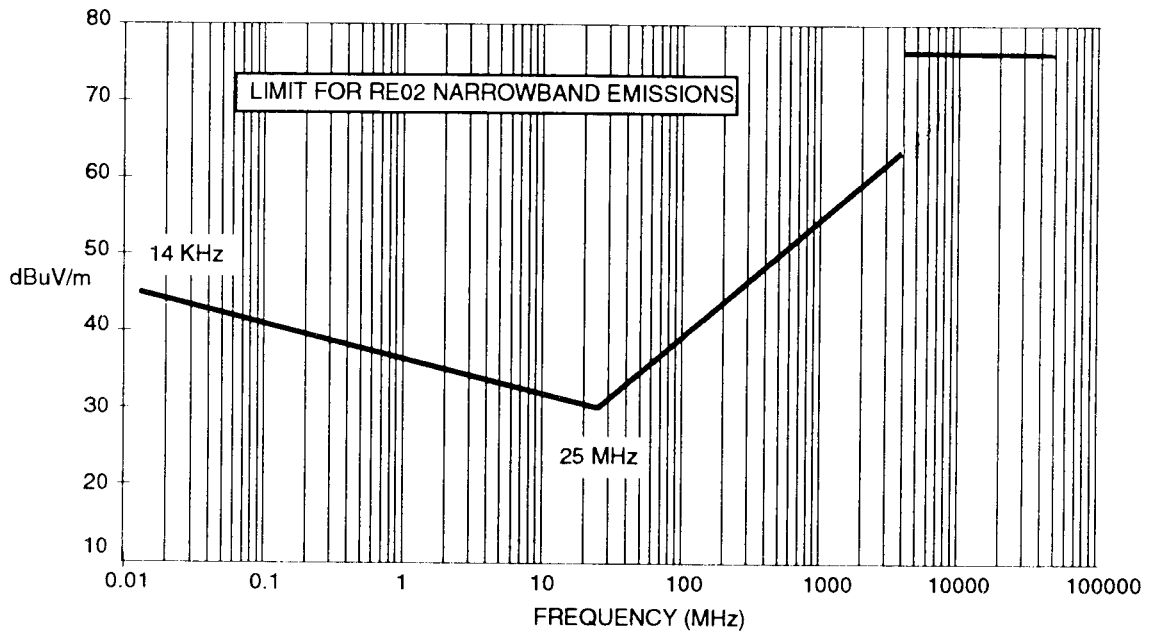

FIGURE 3.2.1.6.1.7.1-1 LIMITS FOR RE02 NARROWBAND EMISSIONS

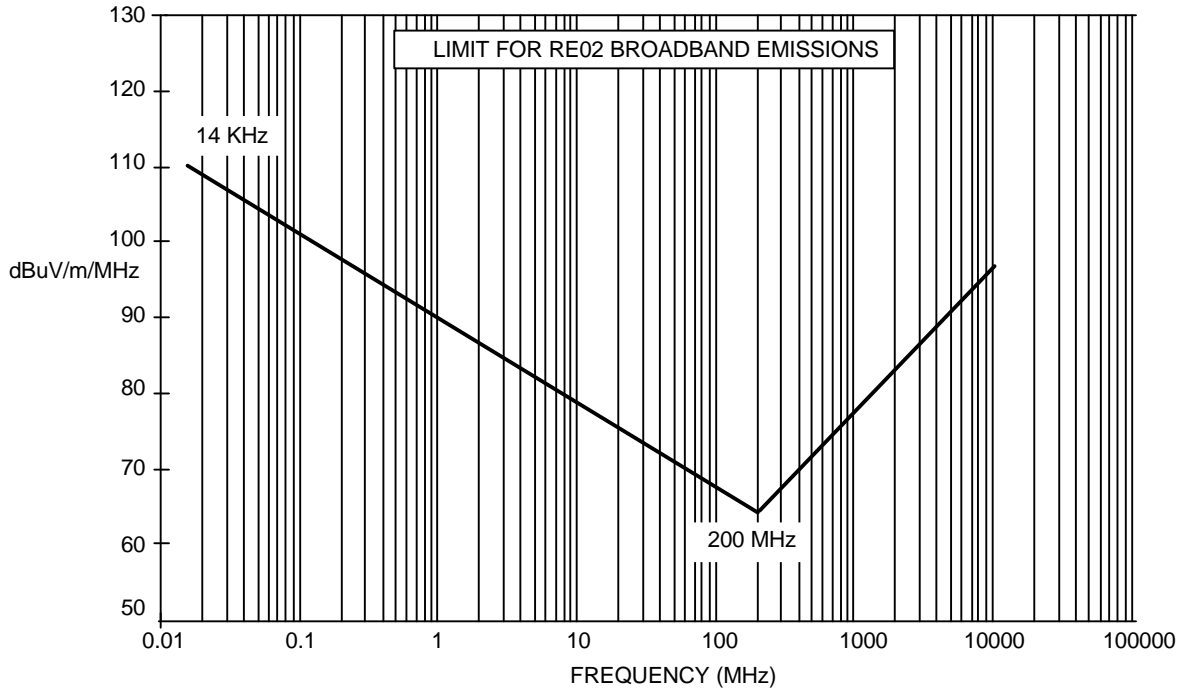

FIGURE 3.2.1.6.1.7.2-1 LIMIT FOR RE02 BROADBAND EMISSIONS

3.2.1.6.2 THERMAL

Heat is transferred between the APAS and the PMA by conduction across the mechanical interface and by radiation between the APAS hatch and the interior of the PMA.

3.2.1.6.2.1 APAS TO PMA 2 & PMA 3 PRESSURIZED/UNPRESSURIZED, OPERATIONAL

Power shall be provided to heaters located on the PMA to precondition the APAS for operation during Orbiter docking and undocking.

The APAS body temperature at the APAS/PMA interface must be maintained within the range shown in Table 3.2.1.6.2.1-1 for the extreme cold and hot environments present during APAS operation. The contact conductance (h_cA) at the interface and the total conduction (dkA/dX) between the APAS interface and the PMA interface are also defined in this table.

3.2.1.6.2.2 APAS TO PMA-2 & PMA-3, UNPRESSURIZED, NON-OPERATIONAL

The APAS body temperature at the APAS/PMA interface must be maintained within the temperature range as shown on Table 3.2.1.6.2.1-1 for the non-operational mission phase. The corresponding contact conductance (h_cA) and conduction (dkA/dX) are also defined in this table.

Within 24 hours after Orbiter docking, heat transfer from the PMA and Orbiter shall maintain the APAS body temperature at the APAS/PMA interface in the range of 60°F to 113°F.

**TABLE 3.2.1.6.2.1-1
APAS DOCKING BASE TEMPERATURES AT APAS/PMA INTERFACE**

APAS Mode	APAS Cold Limit	APAS Hot Limit	h_cA (Btu/hr-°F)	dkA/dx (Btu/hr-°F)
Operational	-16 °F (-27 °C)	138 °F (59 °C)	112	3996
Non-Operational	-68 °F (-56 °C)	138 °F (59 °C)	112	3996

Note: Assume $h_c = 50$ Btu/hr-ft²-°F, Interface area = 2.25 ft², $k = 80$ Btu/hr-ft-°F

3.2.1.6.3 VIBRO-ACOUSTIC

The APAS to PMA Launch Vibro-Acoustic Environment shall be as defined in NSTS-21000-IDD-ISS.

3.2.1.6.4 DEPRESSURIZATION

The APAS to PMA interface shall survive a 1.0 lbm/sec (.4535 kg/s) depressurization rate without loss of functionality as specified herein.

3.2.1.6.5 REPRESSURIZATION

The APAS to PMA interface shall survive a 1.0 lbm/sec (.4535 kg/s) repressurization rate to 15.2 ± 0.2 psia (104.8 KPa +/- 1.4 KPa) without loss of functionality as specified herein.

3.2.2 PRESSURIZED MATING ADAPTER INTERFACE REQUIREMENTS

3.2.2.1 RESERVED

3.2.2.2 STRUCTURAL/MECHANICAL ATTACHMENT

3.2.2.2.1 STRUCTURAL LOADS AT THE INTERFACE PLANE

The PMA shall provide a structural interface for the mechanical attachment of the APAS in accordance with the loads defined below.

3.2.2.2.1.1 MATING IMPACT LOADS

The PMA to APAS mating loads are enveloped by the on-orbit pressure and transient interface loads described below.

3.2.2.2.1.2 LAUNCH LOADS

The PMA interface to the APAS shall survive NSTS launch loads using the load factors for liftoff and landing as defined in Table 3.2.2.2.1.2. These load factors shall be applied concurrently in all possible combinations at the APAS center of gravity.

TABLE 3.2.2.1.2 LAUNCH LIMIT LOAD FACTORS (APAS ACCELERATIONS)

DESCRIPTION	X (Gs)	Y (Gs)	Z (Gs)
PMA-2 APAS CG Liftoff	+1.23/-4.95	+1.97	+11.29
PMA-2 APAS CG Landing	+1.36	+1.28	+7.06/-3.47
PMA-3 APAS CG Liftoff	+0.93/-4.90	+3.19/-3.78	+3.46/-5.27
PMA-3 APAS CG Landing	+2.32/-2.38	+2.26/-2.58	+6.48/-1.57

3.2.2.2.1.3 ON-ORBIT PRESSURE AND INTERFACE LOADS

The PMA to APAS interface shall survive on-orbit pressurization loads for a maximum pressure of 16.0 psia (110.32 KPa) without loss of functionality as specified herein. The PMA to APAS interface shall be designed for the on-orbit interface loads of Table 3.2.1.2.1.3-1. The load components within each load case may be applied concurrently in any combination of positive and negative values for each component. The transient load spectrum associated with these interface load cases is defined in Table 3.2.1.2.1.3-2.

3.2.2.2.2 STRUCTURAL/MECHANICAL ATTACHMENT PROVISIONS

The PMA shall accommodate alignment and mounting provisions for the mechanical attachment of the APAS to PMA.

The PMA hardware shall not interfere with any APAS hardware.

3.2.2.2.3 INTERCONNECTING UTILITY HARDWARE

The PMA interface shall incorporate provisions for the mechanical connection of power, data, instrumentation, video, and audio utilities between the APAS and PMA.

3.2.2.2.3.1 ACCESSIBILITY

The external utility interface design shall comply with SSP 50005, ISS Flight Crew Standards, paragraphs 14.3, 14.4, 14.5.3, and 14.6, for accessibility by EVA-suited crew members. The internal utility interface design shall comply with SSP 50005, paragraph 12.3.1, for IVA accessibility.

3.2.2.2.3.2 REDUNDANCY

The PMA shall accommodate redundant utility interfaces for PMA and APAS Command and Data Handling (C&DH) Buses and power connections. Alternate or redundant functional paths shall be separated or protected at the interface such that a credible event which causes the loss of one functional path will not result in the loss of the alternate or redundant functional path(s).

3.2.2.2.4 STAY-OUT AND PASSAGEWAYS ENVELOPES

The PMA to APAS stay-out and passageway envelopes shall be as defined in paragraph 3.2.1.2.4.

3.2.2.2.5 ATMOSPHERIC SEALS

The PMA shall provide a smooth sealing surface for the pressure seals on the APAS at the interface.

3.2.2.2.5.1 LEAKAGE

The PMA to APAS interface shall not exceed 5×10^{-4} sccs leakage at 14.9 psi (102 KPa) averaged over a 24 hour period.

3.2.2.2.6 APAS THERMAL BLANKETS

The PMA's shall provide attachment points to facilitate installation of the APAS thermal blanket after installation of the APDS to the PMA.

3.2.2.3 RESERVED

3.2.2.4 ELECTRICAL INTERFACES

The PMA interface to the APAS shall accept two feeds for the transfer of secondary electrical power to the PMA at a nominal 140 VDC, two feeds for the transfer of electrical power routed back to the PMA-2/3 APAS hook motors and one feed for operating the PMA-1 active APAS. This electrical power shall have interface parameters and characteristics in accordance with the requirements of ICD-A-21315-NODE 1, Shuttle Orbiter/Node-1 Cargo Element Interfaces and NSTS-21000-IDD-ISS.

3.2.2.4.1 VOLTAGE RATING

The power interface shall provide for a maximum potential of 165 VDC continuous and a maximum of 180 VDC transient for up to 10 msec.

3.2.2.4.2 MAXIMUM CURRENT RATING

The secondary power interface shall be a maximum of 35 amperes.

3.2.2.4.3 ELECTRICAL CONNECTORS

The electrical connectors shall be in accordance with the requirements specified in SSQ 21635.

3.2.2.4.4 CABLE SPECIFICATIONS

High power utility cables shall be in accordance with the requirements of SSQ 21652. Low power cables shall be in accordance with the requirements of SSQ 21656.

3.2.2.5 ELECTRONIC INTERFACES

The PMA shall provide connectors for the passage of electronic media consisting of data, audio, and video at the PMA/APAS interface.

3.2.2.5.1 DATA BUS INTERFACE

3.2.2.5.1.1 DATA BUS STANDARD

The electrical characteristics and data transfer protocol for the C&DH MIL-STD-1553 interface shall conform to MIL-STD-1553B, Notice 2.

3.2.2.5.1.2 INTERFACE BUSES

Only one of the following buses shall cross the PMA-to-APAS-disconnect-panel interface at any one time during the assembly phase of the ISS: PMA-2 and PMA-3 shall distribute LB ORB-N1-1 and LB ORB-N1-2 from the APAS; PMA-2 shall only distribute LB ORB-N2-1 and LB-ORB-N2-2; PMA-3 shall only distribute LB ORB-HAB-1 and LB ORB-HAB-2 from the APAS. Each bus shall be provided with dual redundant data paths across the interface. The data path interfaces for each bus shall conform to the redundancy requirements given in paragraph 3.2.2.2.3.2.

3.2.2.5.1.3 DATA BUS SWITCHING

The PMA shall interface to the 1553 local bus switches accommodated on the APAS.

3.2.2.5.2 AUDIO INTERFACE

3.2.2.5.2.1 AUDIO STANDARD

The PMA shall perform audio data exchange with the PMA in accordance with SSP 50001.

3.2.2.5.2.2 HARDWIRED AUDIO

The PMA-to-APAS interface shall support two-way audio communications. This interface shall accommodate up to ten (10) hardwired audio signals to and from the APAS.

3.2.2.5.3 VIDEO INTERFACE

3.2.2.5.3.1 VIDEO STANDARD

The PMA shall perform video data exchange with the APAS in accordance with SSP 50002.

3.2.2.5.3.2 HARDWIRED VIDEO

The PMA-to-APAS interface shall support two-way video communications. This interface shall distribute three (3) hardwired video signals to and from the APAS.

3.2.2.5.4 INSTRUMENTATION INTERFACE

3.2.2.5.4.1 ACS MODING INSTRUMENTATION

The PMA-to-APAS interface shall accept instrumentation signals from the APAS for Attitude Control System (ACS) moding. This interface shall accept signals from twelve (12) capture indicators, six (6) interface sealed indicators, and four (4) undocking complete indicators. The contact resistance of these indicators at the PMA-to-APAS interface shall be 1.5 ohms maximum at 0.1 mA and 15 Vdc.

3.2.2.5.4.2 TEMPERATURE SENSOR INSTRUMENTATION

The PMA-to-APAS interface shall accept instrumentation signals from the APAS for temperature sensing. This interface shall accept signals from four (4) temperature sensors. The contact resistance of these indicators at the PMA-to-APAS interface shall be 1.5 ohms maximum at 0.1 mA and 15 Vdc.

3.2.2.5.4.3 HOOK MOTOR INSTRUMENTATION

The PMA-to-APAS interface shall accept instrumentation signals from the APAS for Hooks Open and Hooks Closed indications. This interface shall transfer signals from eight (8) Hook Motor indicators (in two places) and four (4) Hooks Closed indicators (in two places) to be looped back into the APAS for distribution.

3.2.2.5.4.4 PMA-1 ACTIVE APAS INSTRUMENTATION

The PMA-2,3-to-APAS interface shall receive instrumentation signals from the APAS for the operation of the PMA-1 active APAS as specified in JSC-26938, Procurement Specification for the APDS for the ISS Missions, and shall be passed to PMA-1 for transfer to the active APAS.

3.2.2.5.5 ELECTRONIC CABLE SPECIFICATIONS

3.2.2.5.5.1 DATA BUS CABLE SPECIFICATIONS

The PMA data bus cables shall be in accordance with the requirements of SSQ 21655 for 75 ohm balanced, shielded pair cables.

3.2.2.5.5.2 AUDIO CABLE SPECIFICATIONS

The PMA audio cables shall be in accordance with the requirements of SSQ 21656.

3.2.2.5.5.3 VIDEO CABLE SPECIFICATIONS

The PMA video cables shall be in accordance with the requirements of SSQ 21655 for 75 ohm balanced, shielded pair cables.

3.2.2.6 ENVIRONMENTS

3.2.2.6.1 ELECTROMAGNETIC EFFECTS

3.2.2.6.1.1 ELECTROMAGNETIC COMPATIBILITY

The PMA shall meet the requirements of SSP 30243.

3.2.2.6.1.2 ELECTROMAGNETIC INTERFERENCE

The PMA shall meet the requirements of SSP 30237.

3.2.2.6.1.3 GROUNDING

The PMA shall meet the requirements of SSP 30240.

3.2.2.6.1.4 BONDING

The PMA shall comply to the requirements of SSP 30245 for the class S, class R and class H bonds. The PMA shall provide provisions for a class R bond with the APAS.

3.2.2.6.1.5 CABLE AND WIRE DESIGN

The PMA cables and wires shall meet the requirements of SSP 30242.

3.2.2.6.2 THERMAL

Heat is transferred between the APAS and the PMA by conduction across the mechanical interface and by radiation between the APAS hatch and the interior of the PMA.

3.2.2.6.2.1 PMA 2 & PMA 3 TO APAS PRESSURIZED/UNPRESSURIZED, OPERATIONAL

Power shall be provided to heaters located on the PMA to precondition the APAS for operation during Orbiter docking and undocking.

The PMA temperature at the PMA/APAS interface must be maintained within the range shown in Table 3.2.1.6.2.1-1 for the extreme cold and hot environments present during APAS operation. The contact conductance (h_cA) at the interface and the total conduction (dkA/dX) between the PMA interface and the APAS interface are also defined in this table.

3.2.2.6.2.2 PMA-2 & PMA-3 TO APAS, UNPRESSURIZED, NON-OPERATIONAL

The PMA temperature at the PMA/APAS interface must be maintained within the temperature range as shown on Table 3.2.1.6.2.1-1 for the non-operational mission phase. The corresponding contact conductance (h_cA) and conduction (dkA/dX) are also defined in this table.

Within 24 hours after Orbiter docking, heat transfer from the PMA and Orbiter shall maintain the APAS body temperature at the APAS/PMA interface in the range of 60°F to 113°F.

3.2.2.6.3 VIBRO-ACOUSTIC

The PMA to APAS Launch Vibro-Acoustic Environment shall be as defined in NSTS-21000-IDD-ISS.

3.2.2.6.4 DEPRESSURIZATION

The PMA to APAS interface shall survive a 1.0 lbm/sec (.4535 kg/s) depressurization rate without loss of functionality as specified herein.

3.2.2.6.5 REPRESSURIZATION

The APAS to PMA interface shall survive a 1.0 lbm/sec (.4535 kg/s) repressurization rate to 15.2 ± 0.2 psia (104.8 KPa +/- 1.4 KPa) without loss of functionality as specified herein.